

TERMINAL
CONTINUOUS

生产车间 PRODUCTION WORKSHOP

拥有完整的产业链，从五金与注塑的模具设计与制造，五金件冲压，注塑，装配皆可自主完成。现有自主研发的自动装配55台，可规模化生产，日产能达到500万粒。

It has a complete industrial chain, which can be completed independently from hardware and injection mold design and manufacturing, hardware stamping, injection molding and assembly. At present, there are 55 self-developed automatic assembly units, which can be produced on a large scale, and the daily output can reach 5 million.



强大生产能力 Production capacity

2500多种端子 | 72小时到货 | 成本价快速开模





实验设备 LABORATORY EQUIPMENT

公司注重技术开发和市场开拓, 推行全面环保及ISO9000质量管理, 在品质优先的企业文化下, 成为与客户共同的运营策略, 目前公司大部分产品通过UL、CUL认证。公司拥有设备齐全的实验室, 能对接线端子的各项标准进行检测和验证。

The company pay attention to technology development and market development, promote environmental protection and ISO9000 quality management, under the enterprise culture of quality priority, to become the common operation strategy with customers, the most of the products have been passed UL, CUL certification at present. The company has a well-equipped laboratory which can check and verify the overall standard of the terminal.



针焰试验机
Needle-flame Tester



可编程式高低温试验机
Programmable high and low temperature testing machine



视觉检测仪
Visual detector



温升试验机
Temperature rising tester



膜厚测试仪
Film thickness tester



投影仪
Projector



微电脑拉力试验机
Microcomputer tensile tester



插拔力测试仪
Push-pull tester



维氏硬度测试仪
Vickers hardness tester



直流低电阻测试仪
Dc low resistance tester



精密老化试验机
Precision aging tester



高耐压仪/介电强度试验机
High voltage tester/Dielectric strength tester



恒温油槽
Thermostatic oil bath



盐水喷雾测试仪
Salt spray tester



RoHs 测试仪
RoHs tester



绝缘电阻测试仪
Insulation Resistance Tester



电脑插拔力测试仪
Computer plugging force tester



端子截面测试仪
Terminal section tester



目录
CONTENTS连续冷压端子
CONTINUOUS COLD-PRESSED TERMINALS

圆形端子 RING TERMINAL

RNB(无绝缘护套圆形端子)Non-Insulated Ring Terminal -----03

RVN(绝缘护套圆形端子)Insulated Ring Terminal -----05

叉形端子 SPADE TERMINAL

SNB(无绝缘护套叉形端子)Non-Insulated Spade Terminal -----09

SVN(绝缘护套叉形端子)Insulated Spade Terminal -----10

片形端子 BLADE TERMINAL

DBN(无绝缘护套片形端子)Non-Insulated Blade Terminal -----14

DBVN(绝缘护套片形端子)Insulated Blade Terminal -----15

针形端子 PIN TERMINAL

PTN(无绝缘护套针形端子)Non-Insulated Pin Terminal -----16

PTVN(绝缘护套针形端子)Insulated Pin Terminal -----17

公、母插端子 FEMALE AND MALE TERMINAL

FDD(绝缘护套母插端子)Insulated Female Terminal -----18

MDD(绝缘护套公插端子)Insulating Male Terminal -----19

STNY(连续预绝缘母端)Continuous Preinsulation Female Terminal -----20

LTNY(连续预绝缘带锁)Continuous Preinsulation With Lock -----20

FDFN(尼龙全绝缘护套母插端子)Nylon-Fully Insulated Female Terminal-----21

MDFN(尼龙全绝缘护套公插端子)Nylon-Fully Insulating Male Terminal-----22

FLDNY(尼龙全绝缘护套旗形母插端子)Nylon-Flag Female Insulating Joint Terminal-----24

子弹形公、母插端子 BULLET RECEPTACLES

MPD(绝缘护套子弹形公插端子)Insulated Male bullet-----24

FREN(尼龙全绝缘护套子弹形母插端子)Nylon-Fully Insulated Female Bullet Receptacle-----25

MRFNY(尼龙全绝缘护套子弹形公插端子)Nylon-Fully Insulated Male Bullet Receptacle-----25

CE(接线帽)Wiring cap -----26

管形端子 CORD END TERMINAL

EVN(尼龙绝缘护套管形端子)Nylon-insulated Cord End Terminal -----27

连续端子 CONTINUOUS TERMINALS

2.8直型母端110 "Terminals-----	29
LW11005四方插母端 110"Squareterminal-----	29
2.8直型带锁母端 110"Terminals-----	30
2.8旗型母端 110" FlagTerminals-----	30
2.8公母一体端子 110" Terminals -----	30
2.8公端 110" Terminals -----	31
2.8其它端子 110" Terminals -----	31
2.8直型软护套110" Sleeves -----	32
2.8直型硬护套110" Sleeves -----	32
4.8直型端子 187" Terminals-----	33
4.8直形带锁端子187"Terminals-----	34
4.8旗形端子187" Flag Terminals-----	34
4.8旗形单边包线端子187" Flag Terminals-----	35
4.8旗形带锁端子 187" FlagTerminals-----	35
4.8旗形单边带锁系列 187" FlagTerminals-----	35
4.8公母一体端子 187" Terminals-----	36
4.8直型公端 187" Male Terminals-----	36
4.8插片187" Terminals-----	37
4.8直型软护套 187"Sleeves-----	38
4.8直型倒穿软护套187" Sleeves -----	38
4.8旗型护套 187"flag Sleeves-----	38
4.8旗型带锁护 187"flag Sleeves-----	38
4.8直型硅胶护套187" Sleeves-----	39
4.8旗型硬护套187"flag Sleeves-----	39
4.8直型硬护套 187" Sleeves-----	39
4.8旗型硅胶护套187" Sleeves-----	39
5.2直型母端 205" Terminals-----	40
5.2直型带锁母端 205" Terminals-----	41
5.2旗形母端 205" Terminals-----	41
5.2直形软护套 205"Sleeves-----	41
5.2旗形软护套 205"Flag Sleeves-----	41
6.3直型母端 250" Series Terminals-----	42
6.3直型带锁端子250" Series Terminals-----	43
6.3旗形端子250" Flag Series Terminals-----	43
6.3旗形端子单边包线 250" Flag Series Terminals-----	44
6.3旗形带锁端子250" Flag Series Terminals-----	45
6.3旗形带锁端子单边包线 250" Flag Series Terminals-----	45
6.3公母一体端子 250" Series Terminals-----	45
6.3插片端子 250" TAB Terminals-----	46
6.3插片端子 250" TAB Terminals-----	47
6.3直型软护套 250" Sleeves-----	47
6.3直型倒穿软护套 250" Sleeves-----	48
6.3旗型护套 250" flag Sleeves-----	48
6.3旗型硅胶护套 250" Sleeves-----	48
6.3直型硅胶护套 250" Sleeves-----	48
6.3直型硬护套 250" Sleeves-----	48
4.8旗型硬护套 187"flag Sleeves-----	48
圆型连续端子 Ring Terminals-----	49

圆型单脚连续端子 Ring Terminals	52
圆型太阳止滑连续端子 Ring Terminals	52
叉形连续端子 Spade Terminals	53
碰焊端子 Welding Terminals	54
圆形碰焊端子 Welding Terminals	54
子弹形公端 Bullet Terminals	55
子弹形母端 Bullet Terminals	55
子弹型端子软护套 Bullet Sleeves	56
铜管端子 PIN Terminals	57
铜针端子 Brass Needle	57
接线包线端子 Button Terminals	58
鲨鱼齿 Shark Teeth Splicer	61
汽车连续端子 Car Type Terminals	63
铜带 Splice Ribbon	63

单粒冷压端子

SINGLE COLD PRESSED TERMINALS

圆形端子 RING TERMINAL

RNB(无绝缘护套圆形端子) Non-Insulated Ring Terminal	65
RV(PVC绝缘护套圆形端子) Vinyl-Insulated Ring Terminal	73
RVN(尼龙绝缘护套圆形端子) Nylon-Insulated Ring Terminal	75
RVN-D(尼龙绝缘护套圆形端子(加铜套)) Nylon-Insulated Ring Terminal(Double Copper Sleeve)	77

叉形端子 SPADE TERMINAL

SNB(无绝缘护套叉形端子) Non-Insulated Spade Terminal	79
SV(PVC绝缘护套叉形端子) Vinyl-Insulated Spade Terminal	81
SVN(尼龙绝缘护套叉形端子) Nylon-Insulated Spade Terminal	83
SVN-D(尼龙绝缘护套叉形端子(加铜套)) Nylon-Insulated Spade Terminal(Double Copper Sleeve)	85

片形端子 BLADE TERMINAL

DBN(无绝缘护套片形端子) Non-Insulated Blade Terminal	87
DBV(PVC绝缘护套片形端子) Vinyl-Insulated Blade Terminal	88
DBVN(尼龙绝缘护套片形端子) Nylon-Insulated Blade Terminal	89
DBVN-D(尼龙绝缘护套片形端子(加铜套)) Nylon-Insulated Blade Terminal(Double Copper Sleeve)	90

针形端子 PIN TERMINAL

PTN(无绝缘护套针形端子) Non-Insulated Pin Terminal	91
PTV(PVC绝缘护套针形端子) Vinyl-Insulated Pin Terminal	92
PTVN(尼龙绝缘护套针形端子) Nylon-Insulated Pin Terminal	93
PTVN-D(尼龙绝缘护套针形端子(加铜套)) Nylon-Insulated Pin Terminal(Double Copper Sleeve)	94
PTN(无绝缘护套针形端子) Non-Insulated Pin Terminal	95

C45铜管片形端子 C45 COPPER TUBE TERMINAL

C(C45铜管片形端子) C45 Copper Tube Terminal	95
---------------------------------------	----

短形中间平行端子 PARALLEL TERMINAL

PNT(无绝缘护套短形中间平行端子) Non-Insulated Parallel Terminal	96
PVT(PVC全绝缘护套短形中间平行端子) Vinyl-Insulated Parallel Terminal	97

中间连接端子 BUTT SPLICE TERMINAL

BN(无绝缘护套中间连接端子) Non-Insulated Butt Splices Terminal	98
BV(PVC全绝缘护套中间连接端子) Vinyl-Insulated Butt Splices Terminal	99
BNYF(尼龙全绝缘护套中间连接端子) Nylon-Insulated Butt Splices Terminal	100
BHT(热缩型防水全绝缘护套中间连接端子) Heat Shrink Insulated	100

公、母插端子 FEMALE AND MALE TERMINAL

FDD(PVC绝缘护套母插端子) Vinyl-Insulated Female Terminal	101
MDD(PVC绝缘护套公插端子) Vinyl-Insulated Male Terminal	102
FDDN(尼龙绝缘护套母插端子) Nylon-Insulated Female Terminal	103
MDDN(尼龙绝缘护套公插端子) Nylon-Insulating Male Terminal	104
FDD-D(PVC绝缘护套母插端子(加铜套)) Vinyl-Insulated Female Terminal(Double Copper Sleeve)	105
FDDN-D(尼龙绝缘护套母插端子(加铜套)) Nylon-Insulated Female Terminal(Double Copper Sleeve)	106
MDDN-D(尼龙绝缘护套公插端子(加铜套)) Nylon-Insulated Male Terminal(Double Copper Sleeve)	107
FDFD(PVC全绝缘护套母插端子) Vinyl-Fully Insulated Female Terminal	108
FDFN(尼龙全绝缘护套母插端子) Nylon-Fully Insulated Female Terminal	109
MDFN(尼龙全绝缘护套公插端子) Nylon-Fully Insulating Male Terminal	110
FDFD-D(PVC全绝缘护套母插端子(加铜套)) Vinyl-Fully Insulated Female Terminal(Double Copper Sleeve)	111
FDFN-D(尼龙全绝缘护套母插端子(加铜套)) Nylon-Fully Insulated Female Terminal(Double Copper Sleeve)	112
MDFN-D(尼龙全绝缘护套公插端子(加铜套)) Nylon-Fully Insulated Male Terminal(Double Copper Sleeve)	113
FLDNY(尼龙全绝缘护套旗形母插端子) Nylon-Flag Female Insulating Joint Terminal	113

肩背形公母插端子 PIGGY BACK DISCONNECT

PBDD(PVC绝缘护套肩背形公母插端子) Vinyl-Insulated Piggy Back Disconnect	114
PBDDN(尼龙绝缘护套肩背形公母插端子) Nylon-Insulated Piggy Back Disconnect	114
PBDFN(尼龙全绝缘护套肩背形公母插端子) Nylon-Fully Insulated Piggy Back Disconnect	115
PBDDN-D(尼龙绝缘护套肩背形公母插端子(加铜套)) Nylon-Insulated Piggy Back Disconnect(Double Copper Sleeve)	115
PBDEN-D(尼龙全绝缘护套肩背形公母插端子(加铜套)) Nylon-Fully Insulated Piggy Back Disconnect(Double Copper Sleeve)	116

子弹形公、母插端子 BULLET RECEPTACLES

FRD(PVC全绝缘护套子弹形母插端子) Vinyl-Fully Insulated Bullet Receptacles	116
MPD(PVC绝缘护套子弹形公插端子) Vinyl-Insulated Male Bullet	117
FRENY(尼龙全绝缘护套子弹形母插端子) Nylon-Fully Insulated Female Bullet Receptacle	118
MPFNY(尼龙全绝缘护套子弹形公插端子) Nylon-Fully Insulated Male Bullet Receptacle	118

管形端子 CORD END TERMINAL

EN(无绝缘护套管形端子) Non-Insulated Cord End Terminal	119
EVN(尼龙绝缘护套管形端子) Nylon-Insulated Cord End Terminal	121
TEVN(尼龙绝缘护套双线管形端子) Nylon-Insulated Twin Cord End Terminal	123

紫铜管端子 COPPER TUBE TERMINAL

SC开口端子 SC copper tube terminals	124
HUP闭口端子 HUP copper tube terminals	126
GC喇叭口端子 GC copper tube terminals	128
GPH90度端子 GPH90 copper tube terminals	130

连续冷压端子产品描述

CONTINUOUS COLD PRESSED TERMINALS DESCRIPTION ON PRODUCTS

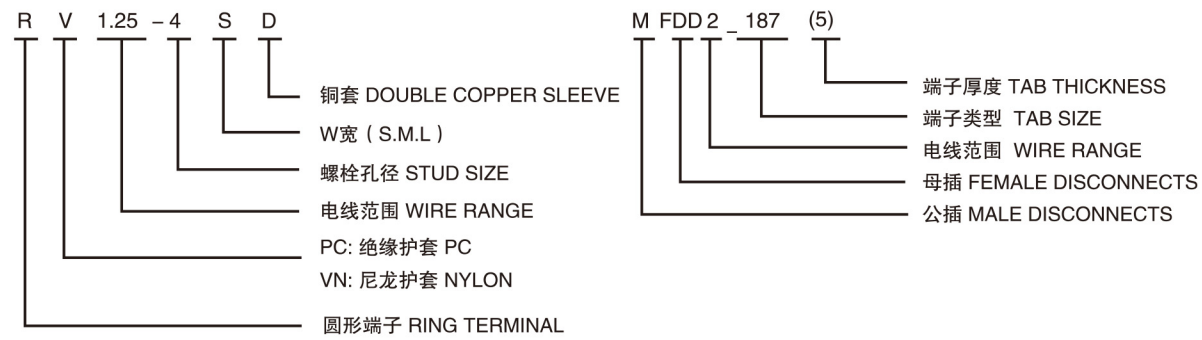

产品代号	产品类型	PRODUCTS TYPE
R	圆形端子	RING TERMINAL
S	叉形端子	SPADE TERMINAL
DB	片形端子	BLADE TERMINAL
PT	针形端子	PIN TERMINAL
FD	对插形母插端子	FEMALE TERMINAL
FD	对插形公插端子	MALE TERMINAL
FLD	旗型母插端子	FLAG FEMALE TERMINAL
MP	子弹形公插端子	MALE BULLET TERMINAL
FR	子弹形母插端子	FEMALE BULLET TERMINAL
CE	接线帽端子	WIRING CAP TERMINAL
PNT	短形中间平行端子	PARALLEL TERMINAL
B	中间平行端子	BUTT SPLICE TERMINAL
PB	肩背形公母插子	PIGGY BACK TERMINAL
E	管形端子	CORD END TERMINAL
TE	双线形端子	CORD END TERMINAL
SC、HUP、GC、GPH	紫铜管端子	LNTERMEDIATE PARALLELN TERMINAL

连续冷压端子

CONTINUOUS COLD PRESSED TERMINALS



无绝缘护套圆形端子

(适用于软线)

Non-Insulated Ring Terminal

(Apply in flexible wire)

材质: 紫铜 Terminal Body: Copper
表面处理: 镀锡 Plating: Tin

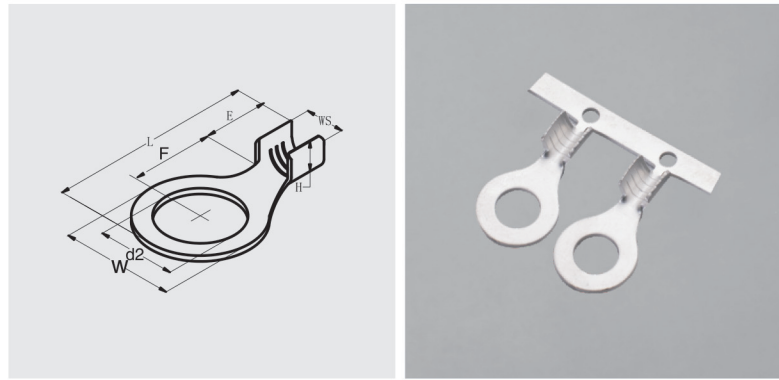

型号 Item NO	导线截面mm ² Cable Size A.W.G	材料厚度 Thickness (mm)	最大电流 Max Current	美制螺栓号 USA Screw	螺栓口直径 Screw Dia. d2(mm)	尺寸 Dimension(mm)					
						W	L	F	E	Ws	H
RNB 1.25-3	0.5~1.5 (22~16)	0.75	19A	#4	3.2	5.7	12.6	5.0	4.8	4.1	4.0
RNB 1.25-3.5 S				#6	3.7	5.7	12.6	5.0			
RNB 1.25-3.5 M				#6	3.7	6.6	14.4	6.3			
RNB 1.25-3.5 L				#6	3.7	8.0	15.8	7.0			
RNB 1.25-4 S				#8	4.3	6.6	14.4	6.3			
RNB 1.25-4 L				#8	4.3	8.0	15.8	7.0			
RNB 1.25-5 S				#10	5.3	8.0	15.8	7.0			
RNB 1.25-5 L				#10	5.3	9.8	17.4	8.0			
RNB 1.25-6 S				1/4	6.4	9.8	17.6	8.0			
RNB 1.25-6 L				1/4	6.4	11.6	21.8	11.1			
RNB 1.25-8				5/16	8.4	11.6	21.8	11.1			
RNB 1.25-10				3/8	10.5	13.6	25.5	14			

型号 Item NO	导线截面mm ² Cable Size A.W.G	材料厚度 Thickness (mm)	最大电流 Max Current	美制螺栓号 USA Screw	螺栓口直径 Screw Dia. d2(mm)	尺寸 Dimension(mm)					
						W	L	F	E	Ws	H
RNB 2-3	1.5~2.5 (16~14)	0.8	27A	#4	3.2	6.6	12.5	4.3	4.8	5.0	5.0
RNB 2-3.5S				#6	3.7	6.6	12.5	4.5			
RNB 2-3.5M				#6	3.7	6.6	14.5	6.5			
RNB 2-3.5L				#6	3.7	8.5	16.8	7.7			
RNB 2-4S				#8	4.3	6.6	14.2	6.5			
RNB 2-4 L				#8	4.3	8.5	16.8	7.7			
RNB 2-5 S				#10	5.3	8.5	16.8	7.7			
RNB 2-5 L				#10	5.3	9.5	16.8	7.7			
RNB 2-6 S				1/4	6.4	9.5	16.8	7.7			
RNB 2-6 L				1/4	6.4	12.0	21.8	11.0			
RNB 2-8				5/16	8.4	12.0	21.8	11.0			
RNB 2-10	3/8	10.5	14.6	26.0	14						

无绝缘护套圆形端子

(适用于软线)

Non-Insulated Ring Terminal

(Apply in flexible wire)

材质: 紫铜 Terminal Body: Copper
表面处理: 镀锡 Plating: Tin

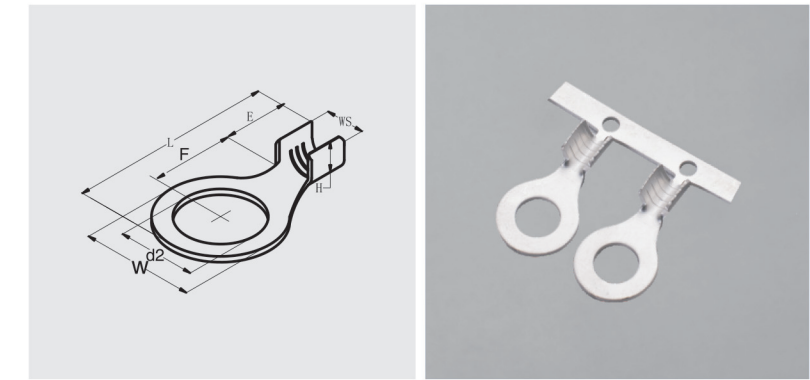

型号 Item NO	导线截面mm ² Cable Size A.W.G	材料厚度 Thickness (mm)	最大电流 Max Current	美制螺栓号 USA Screw	螺栓口直径 Screw Dia. d2(mm)	尺寸 Dimension(mm)					
						W	L	F	E	Ws	H
RNB3.5-4	2.5~4.0 (14~12)	1.0	37A	#8	4.3	8.0	18.0	7.7	6.0	7.0	5.8
RNB3.5-5S				#10	5.3	8.0	18.0	7.7			
RNB3.5-5L				#10	5.3	12.0	21.4	9.3			
RNB3.5-6				1/4	6.4	12.0	21.4	9.3			
RNB3.5-8				5/16	8.4	15.0	27.1	13.6			
RNB3.5-10				3/8	10.5	15.0	27.1	13.6			

型号 Item NO	导线截面mm ² Cable Size A.W.G	材料厚度 Thickness (mm)	最大电流 Max Current	美制螺栓号 USA Screw	螺栓口直径 Screw Dia. d2(mm)	尺寸 Dimension(mm)					
						W	L	F	E	Ws	H
RNB 5.5-3	4.0~6.0 (12~10)	1.0	48A	#4	3.2	7.2	16.2	6.7	6.2	8.0	6.6
RNB 5.5-3.5				#6	3.7	7.2	16.2	6.7			
RNB 5.5-4S				#8	4.3	7.2	16.2	6.7			
RNB 5.5-4 L				#8	4.3	9.5	19.0	8.5			
RNB 5.5-5				#10	5.3	9.5	19.0	8.5			
RNB 5.5-6				1/4	6.4	12.0	23.0	11.0			
RNB 5.5-8				5/16	8.4	15.0	27.5	13.7			
RNB 5.5-10				3/8	10.5	15.0	27.5	13.7			
RNB 5.5-12				1/2	13	19.2	32.4	16			

型号 Item NO	导线截面mm ² Cable Size A.W.G	材料厚度 Thickness (mm)	最大电流 Max Current	美制螺栓号 USA Screw	螺栓口直径 Screw Dia. d2(mm)	尺寸 Dimension(mm)					
						W	L	F	E	Ws	H
RNB 8-4	6.0~10 (8)	1.2	62A	#8	4.3	8.8	23.8	11	8.5	8.3	8.8
RNB 8-4L				#8	4.3	12.0	23.8	9.3			
RNB 8-5S				#10	5.3	8.8	23.8	11			
RNB 8-5M				#10	5.3	12.0	23.8	9.3			
RNB 8-5L				#10	5.3	15.0	29.8	29.5			
RNB 8-6S				1/4	6.4	12.0	23.8	9.3			
RNB 8-6L				1/4	6.4	15.0	29.8	29.5			
RNB 8-8				5/16	8.4	15.0	29.8	29.5			
RNB 8-10				3/8	10.5	15.0	29.8	29.5			

绝缘护套圆形端子

(适用于软线)

Insulated Ring Terminal

(Apply in flexible wire)

材质: 紫铜 Terminal Body: Copper
 护套: 尼龙、PC Insulation: Nylon、PC
 温度: 105°C、115°C Temperature: 105°C、115°C
 表面处理: 镀锡 Plating: Tin

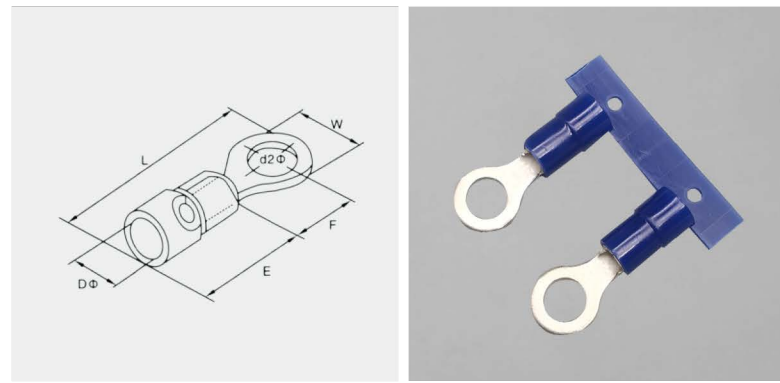

型号 Item NO	导线截面mm ² Cable Size A.W.G	材料厚度 Thickness (mm)	最大电流 Max Current	美制螺栓号 USA Screw	螺栓口直径 Screw Dia. d2(mm)	尺寸 Dimension(mm)					颜色 Color
						W	L	F	E	Dφ	
RVN 1.25-3	0.5~1.5 (22~16)	0.75	19A	#4	3.2	5.7	18.5	5.0	10.5	4.0	红 Red
RVN 1.25-3.5 S				#6	3.7	5.7	18.5	5.0			
RVN 1.25-3.5 M				#6	3.7	6.6	20.0	6.3			
RVN 1.25-3.5 L				#6	3.7	8.0	21.5	7.0			
RVN 1.25-4 S				#8	4.3	6.6	20.1	6.3			
RVN 1.25-4 L				#8	4.3	8.0	21.5	7.0			
RVN 1.25-5 S				#10	5.3	8.0	21.5	7.0			
RVN 1.25-5 L				#10	5.3	9.8	23.5	8.0			
RVN 1.25-6 S				1/4	6.4	9.8	23.0	8.0			
RVN 1.25-6 L				1/4	6.4	11.6	27.5	11			
RVN 1.25-8				5/16	8.4	11.6	27.5	11			
RVN 1.25-10				3/8	10.5	13.6	31.0	14			

型号 Item NO	导线截面mm ² Cable Size A.W.G	材料厚度 Thickness (mm)	最大电流 Max Current	美制螺栓号 USA Screw	螺栓口直径 Screw Dia. d2(mm)	尺寸 Dimension(mm)					颜色 Color
						W	L	F	E	Dφ	
RVN 2-3	1.5~2.5 (16~14)	0.8	27A	#4	3.2	6.6	18	4.3	10.5	4.6	蓝 Blue
RVN 2-3.5 S				#6	3.7	6.6	18	4.3			
RVN 2-3.5 M				#6	3.7	6.6	20.1	6.5			
RVN 2-3.5 L				#6	3.7	8.5	21.8	7.7			
RVN 2-4 S				#8	4.3	6.6	20.1	6.5			
RVN 2-4 L				#8	4.3	8.5	22.4	7.7			
RVN 2-5 S				#10	5.3	8.5	22.4	7.7			
RVN 2-5 L				#10	5.3	9.5	22.4	7.7			
RVN 2-6S				1/4	6.4	9.5	22.4	7.7			
RVN 2-6L				1/4	6.4	12.0	27.5	11			
RVN 2-8				5/16	8.4	12.0	27.5	11			
RVN 2-10				3/8	10.5	14.6	31.5	14			

绝缘护套圆形端子

(适用于软线)

Insulated Ring Terminal

(Apply in flexible wire)

材质: 紫铜 Terminal Body: Copper
 护套: 尼龙、PC Insulation: Nylon、PC
 温度: 105°C、115°C Temperature: 105°C、115°C
 表面处理: 镀锡 Plating: Tin

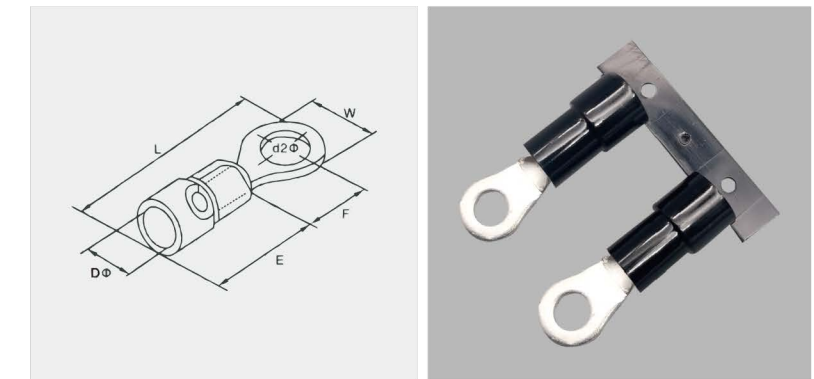

型号 Item NO	导线截面mm ² Cable Size A.W.G	材料厚度 Thickness (mm)	最大电流 Max Current	美制螺栓号 USA Screw	螺栓口直径 Screw Dia. d2(mm)	尺寸 Dimension(mm)					颜色 Color
						W	L	F	E	Dφ	
RVN 3.5-4	2.5~4.0 (14~12)	1.0	37A	#8	4.3	8.0	26.4	8.5	14.2	6.5	黑 Black
RVN 3.5-5 S				#10	5.3	8.0	26.4	8.5			
RVN 3.5-5 L				#10	5.3	12.0	29	9.5			
RVN 3.5-6				1/4	6.4	12.0	29	9.5			
RVN 3.5-8				5/16	8.4	15.0	35.5	14			
RVN 3.5-10				3/8	10.5	15.0	35.5	14			

型号 Item NO	导线截面mm ² Cable Size A.W.G	材料厚度 Thickness (mm)	最大电流 Max Current	美制螺栓号 USA Screw	螺栓口直径 Screw Dia. d2(mm)	尺寸 Dimension(mm)					颜色 Color
						W	L	F	E	Dφ	
RVN 5.5-3	4~6 (12~10)	1.0	48A	#4	3.2	7.2	24.3	6.8	14.2	7	黄 Yellow
RVN 5.5-3.5				#6	3.7	7.2	24.3	6.6			
RVN 5.5-4 S				#8	4.3	7.2	24	6.6			
RVN 5.5-4 L				#8	4.3	9.5	27.2	8.3			
RVN 5.5-5				#10	5.3	9.5	27	8.5			
RVN 5.5-6				1/4	6.4	12.0	31	11.0			
RVN 5.5-8				5/16	8.4	15.0	35.5	13.7			
RVN 5.5-10				3/8	10.5	15.0	36	14.2			

绝缘护套圆形端子

(适用于软线)

Insulated Ring Terminal

(Apply in flexible wire)

材质: 紫铜 Terminal Body: Copper
 护套: 尼龙、PC Insulation: Nylon、PC
 温度: 105°C、115°C Temperature: 105°C、115°C
 表面处理: 镀锡 Plating: Tin

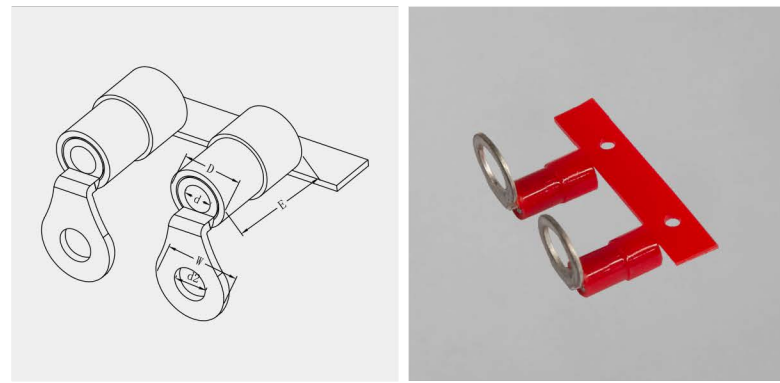

型号 Item NO	导线截面mm ² Cable Size A.W.G	材料厚度 Thickness (mm)	最大电流 Max Current	美制螺栓号 USA Screw	螺栓口直径 Screw Dia. d2(mm)	尺寸 Dimension(mm)				颜色 Color
						W	L	E	D φ	
RVN 1.25-3-90D	0.5-1.5 (22-16)	0.75	19A	#4	3.2	5.7	18.5	10.5	4.0	红 Red
RVN 1.25-3.5 S-90D				#6	3.7	5.7	18.5			
RVN 1.25-3.5 M-90D				#6	3.7	6.6	20.0			
RVN 1.25-3.5 L-90D				#6	3.7	8.0	21.5			
RVN 1.25-4 S-90D				#8	4.3	6.6	20.1			
RVN 1.25-4 L-90D				#8	4.3	8.0	21.5			
RVN 1.25-5 S-90D				#10	5.3	8.0	21.5			
RVN 1.25-5 L-90D				#10	5.3	9.8	23.5			
RVN 1.25-6 S-90D				1/4	6.4	9.8	23.0			
RVN 1.25-6 L-90D				1/4	6.4	11.6	27.5			
RVN 1.25-8-90D				5/16	8.4	11.6	27.5			
RVN 1.25-10-90D				3/8	10.5	13.6	31.0			

型号 Item NO	导线截面mm ² Cable Size A.W.G	材料厚度 Thickness (mm)	最大电流 Max Current	美制螺栓号 USA Screw	螺栓口直径 Screw Dia. d2(mm)	尺寸 Dimension(mm)				颜色 Color
						W	L	E	D φ	
RVN 2-3-90D	1.5-2.5 (16-14)	0.8	27A	#4	3.2	6.6	18	10.5	4.6	蓝 Blue
RVN 2-3.5 S-90D				#6	3.7	6.6	18			
RVN 2-3.5 M-90D				#6	3.7	6.6	20.1			
RVN 2-3.5 L-90D				#6	3.7	8.5	21.8			
RVN 2-4 S-90D				#8	4.3	6.6	20.1			
RVN 2-4 L-90D				#8	4.3	8.5	22.4			
RVN 2-5 S-90D				#10	5.3	8.5	22.4			
RVN 2-5 L-90D				#10	5.3	9.5	22.4			
RVN 2-6S-90D				1/4	6.4	9.5	22.4			
RVN 2-6L-90D				1/4	6.4	12.0	27.5			
RVN 2-8-90D				5/16	8.4	12.0	27.5			
RVN 2-10-90D				3/8	10.5	14.6	31.5			

绝缘护套圆形端子

(适用于软线)

Insulated Ring Terminal

(Apply in flexible wire)

材质: 紫铜 Terminal Body: Copper
 护套: 尼龙、PC Insulation: Nylon、PC
 温度: 105°C、115°C Temperature: 105°C、115°C
 表面处理: 镀锡 Plating: Tin

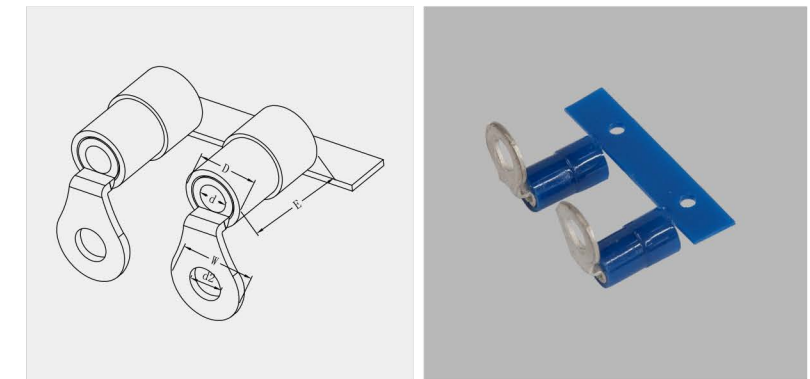

型号 Item NO	导线截面mm ² Cable Size A.W.G	材料厚度 Thickness (mm)	最大电流 Max Current	美制螺栓号 USA Screw	螺栓口直径 Screw Dia. d2(mm)	尺寸 Dimension(mm)				颜色 Color
						W	L	E	D φ	
RVN 3.5-4-90D	2.5-4.0 (14-12)	1.0	37A	#8	4.3	8.0	26.4	14.2	6.5	黑 Black
RVN 3.5-5 S-90D				#10	5.3	8.0	26.4			
RVN 3.5-5 L-90D				#10	5.3	12.0	29			
RVN 3.5-6-90D				1/4	6.4	12.0	29			
RVN 3.5-8-90D				5/16	8.4	15.0	35.5			
RVN 3.5-10-90D				3/8	10.5	15.0	35.5			

型号 Item NO	导线截面mm ² Cable Size A.W.G	材料厚度 Thickness (mm)	最大电流 Max Current	美制螺栓号 USA Screw	螺栓口直径 Screw Dia. d2(mm)	尺寸 Dimension(mm)				颜色 Color
						W	L	E	D φ	
RVN 5.5-3-90D	4-6 (12-10)	1.0	48A	#4	3.2	7.2	24.3	14.2	7	黄 Yellow
RVN 5.5-3.5-90D				#6	3.7	7.2	24.3			
RVN 5.5-4 S-90D				#8	4.3	7.2	24			
RVN 5.5-4 L-90D				#8	4.3	9.5	27.2			
RVN 5.5-5-90D				#10	5.3	9.5	27			
RVN 5.5-6-90D				1/4	6.4	12.0	31			
RVN 5.5-8-90D				5/16	8.4	15.0	35.5			
RVN 5.5-10-90D				3/8	10.5	15.0	36			

无绝缘护套叉形端子

(适用于软线)

Non-Insulated Spade Terminal

(Apply in flexible wire)

材质: 紫铜
表面处理: 镀锡

Terminal Body: Copper
Plating: Tin

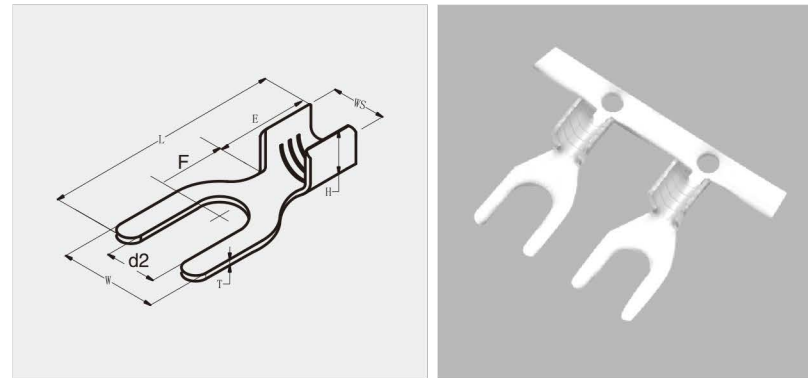

型号 Item NO	导线截面mm ² Cable Size A.W.G	材料厚度 Thickness (mm)	最大电流 Max Current	美制螺栓号 USA Screw	螺栓口直径 Screw Dia. d2(mm)	尺寸 Dimension(mm)					
						W	L	F	E	Ws	H
SNB 1.25-3	0.5~1.5 (22~16)	0.75	19A	#4	3.2	5.7	16.0	6.5	4.8	4.2	4.0
SNB 1.25-3.5 S				#6	3.7	5.7	16.0	6.5			
SNB 1.25-3.5 L				#6	3.7	6.4	16.0	6.5			
SNB 1.25-4 S				#8	4.3	6.4	16.0	6.5			
SNB1.25-4 M				#8	4.3	7.2	16.0	6.5			
SNB 1.25-4 L				#8	4.3	8.1	16.0	6.3			
SNB 1.25-5 S				#10	5.3	8.1	16.0	6.5			
SNB 1.25-5 L				#10	5.3	9.5	16.0	6.5			
SNB 1.25-6 S				1/4	6.4	9.5	16.0	6.5			
SNB 1.25-6 L				1/4	6.4	12.0	22.0	10.6			

型号 Item NO	导线截面mm ² Cable Size A.W.G	材料厚度 Thickness (mm)	最大电流 Max Current	美制螺栓号 USA Screw	螺栓口直径 Screw Dia. d2(mm)	尺寸 Dimension(mm)					
						W	L	F	E	Ws	H
SNB 2-3	1.5~2.5 (16~14)	0.8	27A	#4	3.2	5.7	16.0	6.5	4.8	5.0	5.0
SNB 2-3.5 S				#6	3.7	5.7	16.0	6.5			
SNB 2-3.5 L				#6	3.7	6.2	16.0	6.5			
SNB 2-4 S				#8	4.3	6.4	16.0	6.5			
SNB 2-4 M				#8	4.3	7.2	16.0	6.5			
SNB 2-4 L				#8	4.3	8.1	16.0	6.5			
SNB 2-5 S				#10	5.3	8.1	16.0	6.5			
SNB 2-5 L				#10	5.3	9.5	16.0	6.5			
SNB 2-6 S				1/4	6.4	9.5	16.0	6.5			
SNB 2-6 L				1/4	6.4	12.0	22.0	11.0			

型号 Item NO	导线截面mm ² Cable Size A.W.G	材料厚度 Thickness (mm)	最大电流 Max Current	美制螺栓号 USA Screw	螺栓口直径 Screw Dia. d2(mm)	尺寸 Dimension(mm)					
						W	L	F	E	Ws	H
SNB 3.5-3	2.5~4 (14~12)	1.0	37A	#4	3.2	5.7	18.0	7.0	6.8	7.0	5.8
SNB 3.5-4 S				#8	4.3	7.2	18.0	7.0			
SNB 3.5-4				#8	4.3	8.0	18.0	7.0			
SNB 3.5-5				#10	5.3	8.0	18.0	7.0			
SNB 3.5-6				1/4	6.4	12.0	21.5	8.0			

无绝缘护套叉形端子

(适用于软线)

Non-Insulated Spade Terminal

(Apply in flexible wire)

材质: 紫铜
表面处理: 镀锡

Terminal Body: Copper
Plating: Tin

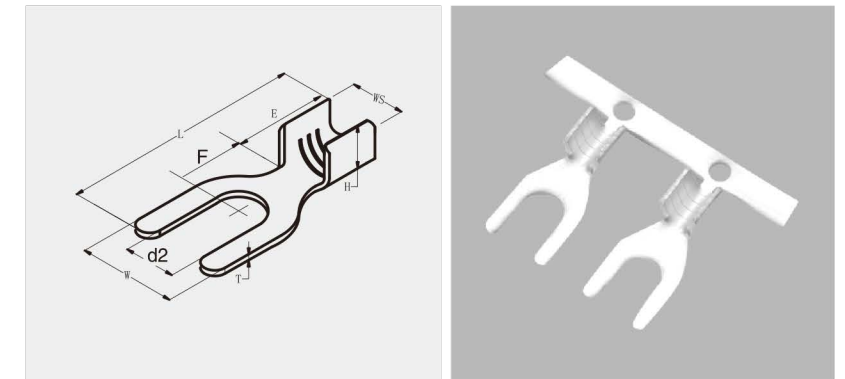

型号 Item NO	导线截面mm ² Cable Size A.W.G	材料厚度 Thickness (mm)	最大电流 Max Current	美制螺栓号 USA Screw	螺栓口直径 Screw Dia. d2(mm)	尺寸 Dimension(mm)					
						W	L	F	E	Ws	H
SNB 5.5-3.5	4~6 (12~10)	1.0	48A	#6	3.7	7.2	18.0	7.5	6.8	8.0	6.6
SNB 5.5-4 S				#8	4.3	8.3	19.0	7.0			
SNB 5.5-4 L				#8	4.3	9.0	19.0	7.0			
SNB 5.5-5				#10	5.3	9.0	19.0	7.5			
SNB 5.5-6 S				1/4	6.4	9.0	19.0	7.5			
SNB 5.5-6 L				1/4	6.4	12.0	25.5	12.0			
SNB 5.5-8				5/16	8.4	14.0	24.5	11.5			

绝缘护套叉形端子

(适用于软线)

Insulated Spade Terminal

(Apply in flexible wire)

材质: 紫铜
护套: 尼龙、PC
温度: 105°C、115°C
表面处理: 镀锡

Terminal Body: Copper
Insulation: Nylon、PC
Temperature: 105°C、115°C
Plating: Tin

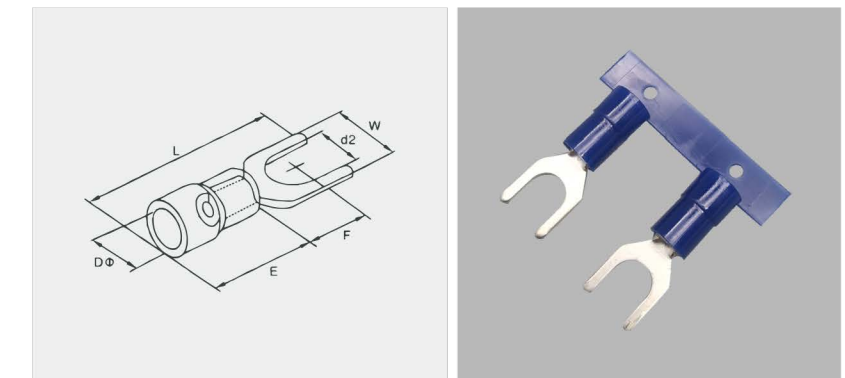

型号 Item NO	导线截面mm ² Cable Size A.W.G	材料厚度 Thickness (mm)	最大电流 Max Current	美制螺栓号 USA Screw	螺栓口直径 Screw Dia. d2(mm)	尺寸 Dimension(mm)					颜色 Color
						W	L	F	E	Dφ	
SVN 1.25-3	0.5~1.5 (22~16)	0.75	19A	#4	3.2	5.7	27.7	6.5	10.5	4.0	红 red
SVN 1.25-3.5 S				#6	3.7	5.7		6.5			
SVN 1.25-3.5 L				#6	3.7	6.4		6.5			
SVN 1.25-4 S				#8	4.3	6.4		6.5			
SVN 1.25-4 M				#8	4.3	7.2		6.5			
SVN 1.25-4 L				#8	4.3	8.1		6.5			
SVN 1.25-5 S				#10	5.3	8.1		6.5			
SVN 1.25-5 L				#10	5.3	9.5		6.5			
SVN 1.25-6 S				1/4	6.4	9.5		6.5			
SVN 1.25-6 L				1/4	6.4	12.0		11.0			

绝缘护套叉形端子

(适用于软线)

Insulated Spade Terminal

(Apply in flexible wire)

材质: 紫铜 Terminal Body: Copper
 护套: 尼龙、PC Insulation: Nylon、PC
 温度: 105°C、115°C Temperature: 105°C、115°C
 表面处理: 镀锡 Plating: Tin

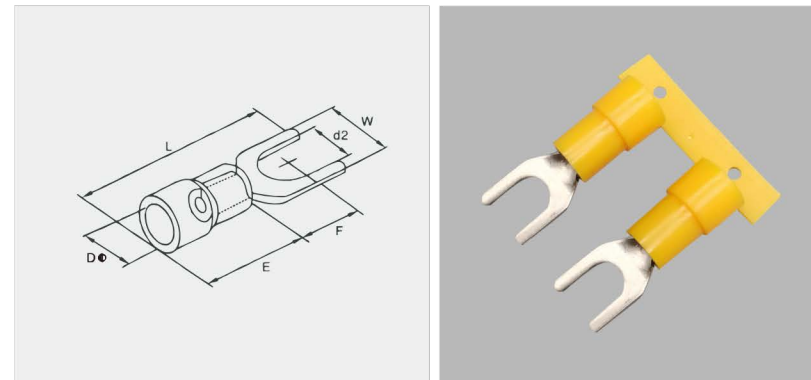

型号 Item NO	导线截面mm ² Cable Size A.W.G	材料厚度 Thickness (mm)	最大电流 Max Current	美制螺栓号 USA Screw	螺栓口直径 Screw Dia. d2(mm)	尺寸 Dimension(mm)					颜色 Color
						W	L	F	E	Dφ	
SVN 2-3	1.5~2.5 (16~14)	0.8	27A	#4	3.2	21.7	21.3	6.5	10.5	4.5	蓝 blue
SVN 2-3.5 S				#6	3.7						
SVN 2-3.5 L				#6	3.7						
SVN 2-4 S				#8	4.3						
SVN 2-4 M				#8	4.3						
SVN 2-4 L				#8	4.3						
SVN 2-5 S				#10	5.3						
SVN 2-5 L				#10	5.3						
SVN 2-6 S				1/4	6.4						
SVN 2-6 L				1/4	6.4	12.0	27.6	11.0			

型号 Item NO	导线截面mm ² Cable Size A.W.G	材料厚度 Thickness (mm)	最大电流 Max Current	美制螺栓号 USA Screw	螺栓口直径 Screw Dia. d2(mm)	尺寸 Dimension(mm)					颜色 Color
						W	L	F	E	Dφ	
SVN 3.5-3	2.5~4 (14~12)	1.0	37A	#4	3.2	14.2	7.2	25.5	7.0	6.4	黑 Black
SVN 3.5-4 S				#8	4.3						
SVN 3.5-4				#8	4.3						
SVN 3.5-5				#10	5.3						
SVN 3.5-6				1/4	6.4						

型号 Item NO	导线截面mm ² Cable Size A.W.G	材料厚度 Thickness (mm)	最大电流 Max Current	美制螺栓号 USA Screw	螺栓口直径 Screw Dia. d2(mm)	尺寸 Dimension(mm)					颜色 Color
						W	L	F	E	Dφ	
SVN 5.5-3.5	4~6 (12~10)	1.0	48A	#6	3.7	14.2	9.0	26.8	7.5	7.0	黄 Yellow
SVN 5.5-4 S				#8	4.3						
SVN 5.5-4 L				#8	4.3						
SVN 5.5-5				#10	5.3						
SVN 5.5-6 S				1/4	6.4						
SVN 5.5-6 L				1/4	6.4						
SVN 5.5-8	5/16	8.4	14.0	31.8	11.5						

绝缘护套叉形端子

(适用于软线)

Insulated Spade Terminal

(Apply in flexible wire)

材质: 紫铜 Terminal Body: Copper
 护套: 尼龙、PC Insulation: Nylon、PC
 温度: 105°C、115°C Temperature: 105°C、115°C
 表面处理: 镀锡 Plating: Tin

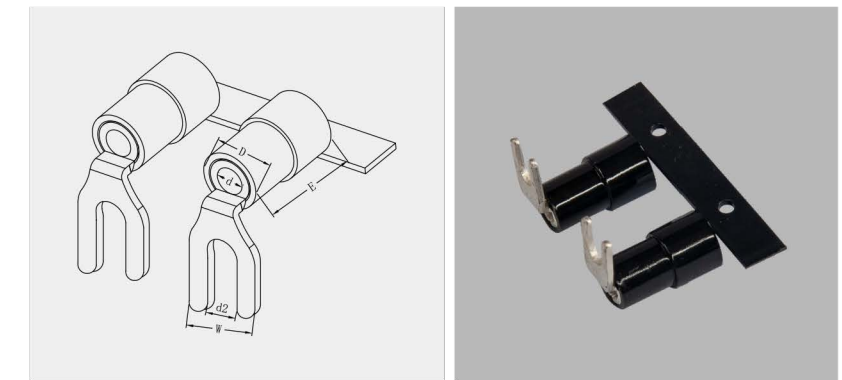

型号 Item NO	导线截面mm ² Cable Size A.W.G	材料厚度 Thickness (mm)	最大电流 Max Current	美制螺栓号 USA Screw	螺栓口直径 Screw Dia. d2(mm)	尺寸 Dimension(mm)				颜色 Color	
						W	L	E	Dφ		
SVN 1.25-3-90D	0.5~1.5 (22~16)	0.75	19A	#4	3.2	27.7	10.5	4.0	4.0	红 red	
SVN 1.25-3.5 S-90D				#6	3.7						
SVN 1.25-3.5 L-90D				#6	3.7						
SVN 1.25-4 S-90D				#8	4.3						
SVN 1.25-4 M-90D				#8	4.3						
SVN 1.25-4 L-90D				#8	4.3						
SVN 1.25-5 S-90D				#10	5.3						
SVN 1.25-5 L-90D				#10	5.3						
SVN 1.25-6 S-90D				1/4	6.4						
SVN 1.25-6 L-90D				1/4	6.4						12.0

绝缘护套叉形端子

(适用于软线)

Insulated Spade Terminal

(Apply in flexible wire)

材质: 紫铜 Terminal Body: Copper
 护套: 尼龙、PC Insulation: Nylon、PC
 温度: 105°C、115°C Temperature: 105°C、115°C
 表面处理: 镀锡 Plating: Tin

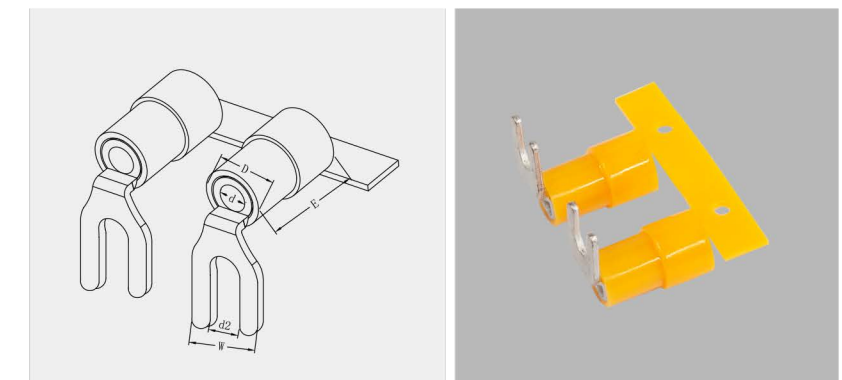

型号 Item NO	导线截面mm ² Cable Size A.W.G	材料厚度 Thickness (mm)	最大电流 Max Current	美制螺栓号 USA Screw	螺栓口直径 Screw Dia. d2(mm)	尺寸 Dimension(mm)				颜色 Color
						W	L	E	Dφ	
SVN 2-3-90D	1.5~2.5 (16~14)	0.8	27A	#4	3.2	21.7	10.5	4.5	4.5	蓝 blue
SVN 2-3.5 S-90D				#6	3.7					
SVN 2-3.5 L-90D				#6	3.7					
SVN 2-4 S-90D				#8	4.3					
SVN 2-4 M-90D				#8	4.3					
SVN 2-4 L-90D				#8	4.3					
SVN 2-5 S-90D				#10	5.3					
SVN 2-5 L-90D				#10	5.3					
SVN 2-6 S-90D				1/4	6.4					
SVN 2-6 L-90D				1/4	6.4					

绝缘护套叉形端子

(适用于软线)

Insulated Spade Terminal

(Apply in flexible wire)

材质: 紫铜 Terminal Body: Copper
 护套: 尼龙、PC Insulation: Nylon、PC
 温度: 105°C、115°C Temperature: 105°C、115°C
 表面处理: 镀锡 Plating: Tin

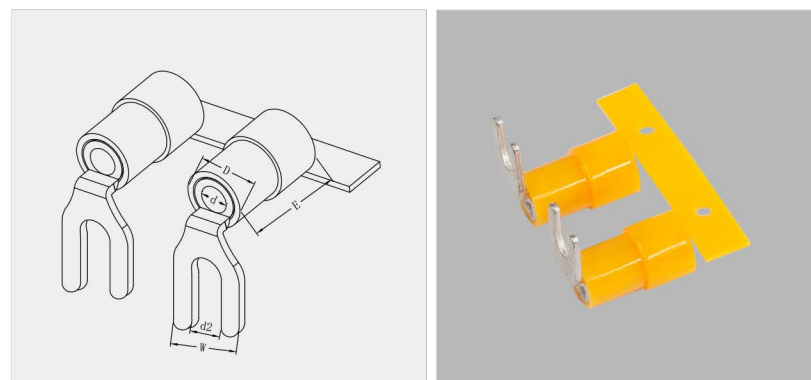

型号 Item NO	导线截面mm ² Cable Size A.W.G	材料厚度 Thickness (mm)	最大电流 Max Current	美制螺栓号 USA Screw	螺栓口直径 Screw Dia. d2(mm)	尺寸 Dimension(mm)				颜色 Color
						W	L	E	D φ	
SVN 3.5-3 -90D	2.5~4 (14~12)	1.0	37A	#4	3.2	5.7	25.5	14.2	6.4	黑 Black
SVN 3.5-4 S-90D				#8	4.3	7.2	25.5			
SVN 3.5-4 -90D				#8	4.3	8.0	25.5			
SVN 3.5-5 -90D				#10	5.3	8.0	25.5			
SVN 3.5-6 -90D				1/4	6.4	12.0	28.5			

型号 Item NO	导线截面mm ² Cable Size A.W.G	材料厚度 Thickness (mm)	最大电流 Max Current	美制螺栓号 USA Screw	螺栓口直径 Screw Dia. d2(mm)	尺寸 Dimension(mm)				颜色 Color
						W	L	E	D φ	
SVN 5.5-3.5-90D	4~6 (12~10)	1.0	48A	#6	3.7	7.2	25.5	14.2	7.0	黄 Yellow
SVN 5.5-4 S-90D				#8	4.3	8.3	26.8			
SVN 5.5-4 L-90D				#8	4.3	9.0	26.8			
SVN 5.5-5 -90D				#10	5.3	9.0	26.8			
SVN 5.5-6 S-90D				1/4	6.4	9.0	26.8			
SVN 5.5-6 L-90D				1/4	6.4	12.0	32.8			
SVN 5.5-8 -90D				5/16	8.4	14.0	31.8			

无绝缘护套片形端子

(适用于软线)

Non -Insulated Blade Terminal

(Apply in flexible wire)

材质: 紫铜 Terminal Body: Copper
 表面处理: 镀锡 Plating: Tin

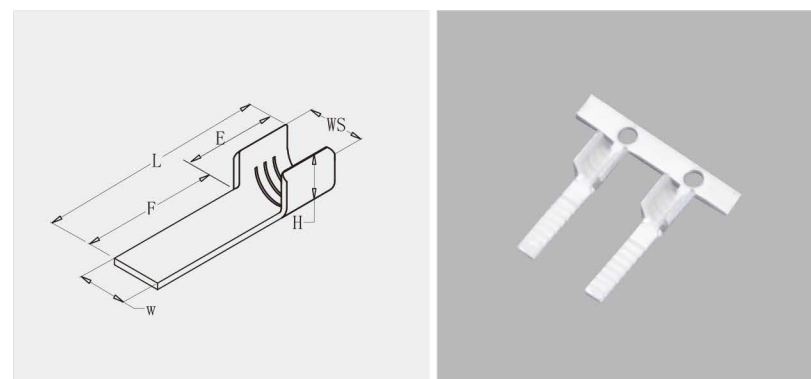

型号 Item NO	导线截面mm ² Cable Size A.W.G	材料厚度 Thickness (mm)	最大电流 Max Current	尺寸 Dimension(mm)					
				W	L	F	E	Ws	H
DBN 1.25-8	0.5~1.5 (22~16)	0.75	19A	2.3	13.0	8.0	4.8	4.2	4.0
DBN 1.25-10				2.3	15	10.0			
DBN 1.25-14				2.3	18.8	14.0			
DBN 1.25-18				2.2	22.8	18.0			

型号 Item NO	导线截面mm ² Cable Size A.W.G	材料厚度 Thickness (mm)	最大电流 Max Current	尺寸 Dimension(mm)					
				W	L	F	E	Ws	H
DBN 2-10	1.5~2.5 (16~14)	0.8	27A	2.8	14.8	10.0	4.8	5.0	5.0
DBN 2-14				2.4	18.8	14.1			
DBN 2-18				2.2	22.8	18.0			

型号 Item NO	导线截面mm ² Cable Size A.W.G	材料厚度 Thickness (mm)	最大电流 Max Current	尺寸 Dimension(mm)					
				W	L	F	E	Ws	H
DBN 5.5-10	4~6 (12~10)	1.0	48A	2.8	16	10.0	6.0	8.0	6.6
DBN 5.5-14				4.5	20.0	14.0			
DBN 5.5-18				4.5	24.0	18.0			

型号 Item NO	材质 Material	材料厚度 Thickness (mm)	电线范围 Wire Rang(AWG)	最大电流 Max Current	尺寸 Dimension(mm)					
					L	W	F	E	Ws	H
DBN 8-14	紫铜 Copper	1.2	6~10(8)	62A	22.6	5.0	14	8.4	8.2	8.9

绝缘护套片形端子

(适用于软线)

Insulated Blade Terminal

(Apply in flexible wire)

材质: 紫铜 Terminal Body: Copper
 护套: 尼龙、PC Insulation: Nylon、PC
 温度: 105°C、115°C Temperature: 105°C、115°C
 表面处理: 镀锡 Plating: Tin

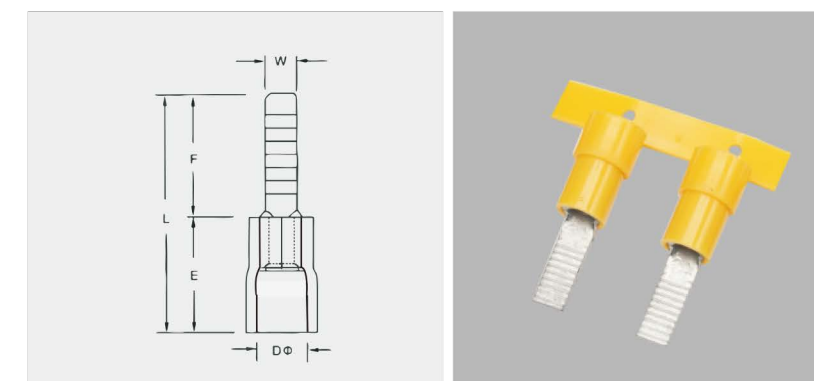

型号 Item NO	导线截面mm ² Cable Size A.W.G	材料厚度 Thickness (mm)	最大电流 Max Current	尺寸 Dimension(mm)					颜色 Color
				w	L	F	E	D φ	
DBVN 1.25-10	0.5~1.5 (22~16)	0.75	19A	2.3	20.5	10.0	10.5	4.0	红 red
DBVN 1.25-11				2.3	20.5	10.0			
DBVN 1.25-14				2.3	24.5	14.0			
DBVN 1.25-18				2.2	28.5	18.0			

型号 Item NO	导线截面mm ² Cable Size A.W.G	材料厚度 Thickness (mm)	最大电流 Max Current	尺寸 Dimension(mm)					颜色 Color
				w	L	F	E	D φ	
DBVN 2-10	1.5~2.5 (16~14)	0.8	27A	2.8	20.5	10.0	10.5	4.6	蓝 blue
DBVN 2-14				2.4	24.5	14.0			
DBVN 2-18				2.2	28.5	18.0			

型号 Item NO	导线截面mm ² Cable Size A.W.G	材料厚度 Thickness (mm)	最大电流 Max Current	尺寸 Dimension(mm)					颜色 Color
				w	L	F	E	D φ	
DBVN 5.5-10	4~6 (12~10)	1.0	48A	2.8	24.2	10.0	14.2	7.0	黄 yellow
DBVN 5.5-14				4.5	28.2	14.0			
DBVN 5.5-18				4.5	32.2	18.0			

无绝缘护套针形端子

(适用于软线)

Non-Insulated Pin Terminal

(Apply in flexible wire)

材质: 紫铜 Terminal Body: Copper
表面处理: 镀锡 Plating: Tin

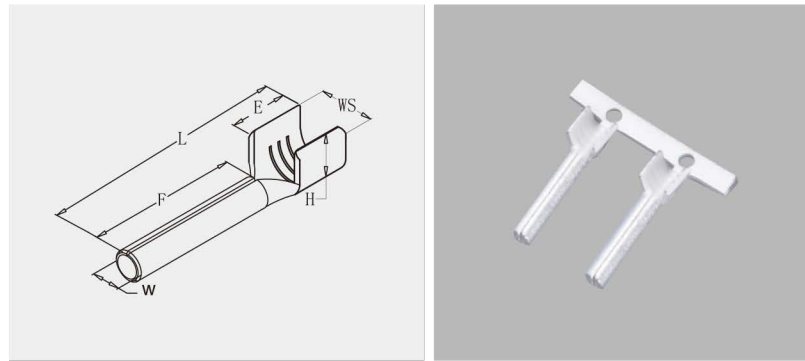

型号 Item NO	导线截面mm ² Cable Size A.W.G	材料厚度 Thickness (mm)	最大电流 Max Current	尺寸 Dimension(mm)					
				W	L	E	F	Ws	H
PTN 1.25-10	0.5~1.5 (22~16)	0.75	19A	1.9	15.2	4.8	10.0	4.1	4.0
PTN 1.25-12				1.9	16.8	4.8	12.0		
PTN 1.25-13				1.9	17.8	4.8	13.0		
PTN 1.25-18				1.9	22.8	4.8	18.0		
PTN 2-10	1.5~2.5 (16~14)	0.8	27A	1.9	14.8	4.8	10.0	5.0	5.0
PTN 2-12				1.9	16.8	4.8	12.0		
PTN 2-13				1.9	17.8	4.8	13.0		
PTN 2-18				1.9	22.8	4.8	18.0		
PTN 3.5-10	2.5~4 (14~12)	1.0	37A	2.8	16.3	6.0	10.3	6.0	6.1
PTN 3.5-13				2.8	19.8	6.0	13.0		
PTN 5.5-13	4-6(12~10)	1.0	48A	2.8	19.3	5.8	13.3	7.6	6.8

绝缘护套针形端子

(适用于软线)

Insulated Pin Terminal

(Apply in flexible wire)

材质: 紫铜 Terminal Body: Copper
护套: 尼龙、PC Insulation: Nylon、PC
温度: 105°C、115°C Temperature: 105°C、115°C
表面处理: 镀锡 Plating: Tin

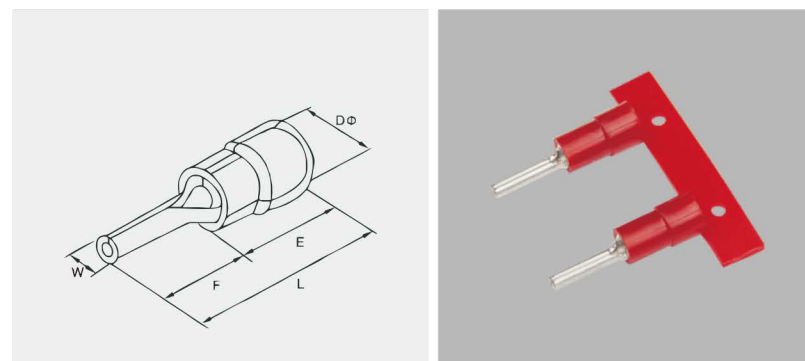

型号 Item NO	导线截面mm ² Cable Size A.W.G	材料厚度 Thickness (mm)	最大电流 Max Current	尺寸 Dimension(mm)					颜色 Color
				W	L	E	F	Dφ	
PTVN 1.25-10	0.5~1.5 (22~16)	0.75	19A	1.9	20.6	10.5	10.0	4.3	红 red
PTVN 1.25-12				1.9	22.7	10.5	12.0		
PTVN 1.25-13				1.9	24.0	11.0	13.0		
PTVN 1.25-18				1.9	29.0	11.0	18.0		
PTVN 2-10	1.5~2.5 (16~14)	0.8	27A	1.9	20.6	0.5	10.0	4.9	蓝 blue
PTVN 2-12				1.9	22.6	0.5	12.0		
PTVN 2-13				1.9	23.6	0.5	13.0		
PTVN 2-18				1.9	28.6	0.5	18.0		
PTVN 3.5-10	2.5~4 (14~12)	1.0	37A	2.8	23.8	13.3	10.0	6.0	黑 Black
PTVN 3.5-13				2.8	26.3	13.3	13.0		
PTVN 5.5-13	4-6(12~10)	1.0	48A	2.8	27.5	14.2	13.0	6.6	黄 yellow

绝缘护套母插端子

(适用于软线)

Insulated Spade Terminal

(Apply in flexible wire)

材质: 黄铜 Terminal Body: Brass
护套: 尼龙、PC Insulation: Nylon、PC
温度: 105°C、115°C Temperature: 105°C、115°C
表面处理: 镀锡 Plating: Tin

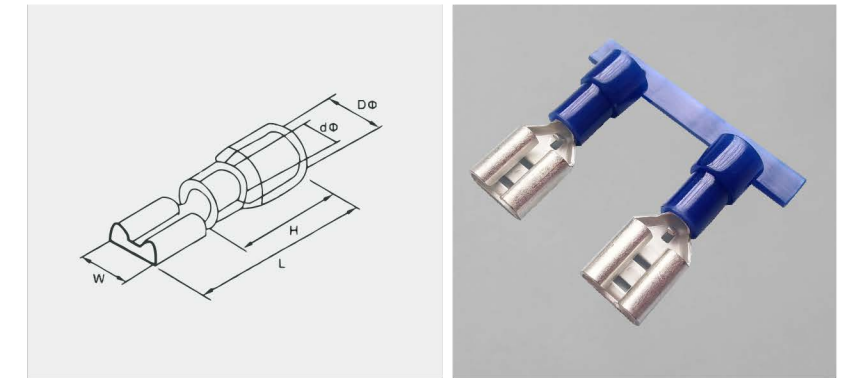

型号 Item NO	导线截面mm ² Cable Size A.W.G	最大电流 Max Current	接插规格 Connecting spec.	材料厚度 Thickness (mm)	尺寸 Dimension(mm)					颜色 Color
					W	Dφ	dφ	L	H	
FDD 1.25-110(5)	0.5~1.5 (22~16)	10A	0.5×2.8	0.3	3.8	4.1	1.7	19.0	11.0	红 red
FDD 1.25-110(8)			0.8×2.8		3.8	4.1	1.7	19.0		
FDD 1.25-187(5)			0.5×4.75		5.8	4.1	1.7	19.0		
FDD 1.25-187(8)			0.8×4.75		5.8	4.1	1.7	19.0		
FDD 1.25-250			0.8×6.35	7.6	3.9	1.7	20.7			

型号 Item NO	导线截面mm ² Cable Size A.W.G	最大电流 Max Current	接插规格 Connecting spec.	材料厚度 Thickness (mm)	尺寸 Dimension(mm)					颜色 Color
					W	Dφ	dφ	L	H	
FDD 2-110(5)	1.5~2.5 (16~14)	15A	0.5×2.8	0.3	3.8	4.7	2.3	19.7	11.5	蓝 blue
FDD 2-110(8)			0.8×2.8		3.8	4.7	2.3	19.7		
FDD 2-187(5)			0.5×4.75		5.6	4.7	2.3	19.7		
FDD 2-187(8)			0.8×4.75		5.6	4.7	2.3	19.7		
FDD 2-250			0.8×6.35	7.4	4.3	2.3	21.5			

型号 Item NO	导线截面mm ² Cable Size A.W.G	最大电流 Max Current	接插规格 Connecting spec.	材料厚度 Thickness (mm)	尺寸 Dimension(mm)					颜色 Color
					W	Dφ	dφ	L	H	
FDD 5.5-250	4-6 (12~10)	24A	0.8×6.35	0.5	7.6	6.2	3.4	24.5	14.0	黄 yellow

绝缘护套公插端子

(适用于软线)

Insulating Male Terminal

(Apply in flexible wire)

材质: 黄铜 Terminal Body: Brass
护套: 尼龙、PC Insulation: Nylon、PC
温度: 105°C、115°C Temperature: 105°C、115°C
表面处理: 镀锡 Plating: Tin

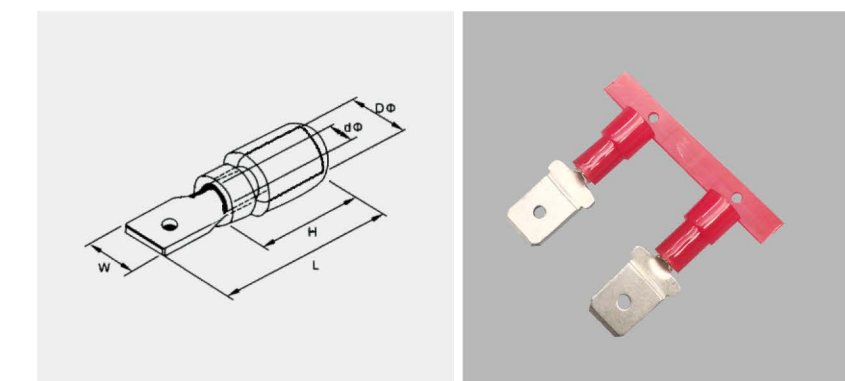

型号 Item NO	导线截面mm ² Cable Size A.W.G	最大电流 Max Current	接插规格 Connecting spec.	材料厚度 Thickness (mm)	尺寸 Dimension(mm)					颜色 Color
					W	Dφ	dφ	L	H	
MDD 1.25-110(5)	0.5~1.5 (22~16)	10A	0.5×2.8	0.5	2.8	4.0	1.7	17.7	11.0	红 red
MDD 1.25-110(8)			0.8×2.8		2.8	4.3	1.7	17.7		
MDD 1.25-187(5)			0.5×4.75		4.75	4.0	1.7	21.0		
MDD 1.25-187(8)			0.8×4.75		4.75	4.0	1.7	21.0		
MDD 1.25-250			0.8×6.35	6.35	4.1	1.7	21.5			

绝缘护套公插端子

(适用于软线)

Insulating Male Terminal
(Apply in flexible wire)

材质: 黄铜 Terminal Body: Brass
护套: 尼龙、PC Insulation: Nylon、PC
温度: 105°C、115°C Temperature: 105°C、115°C
表面处理: 镀锡 Plating: Tin

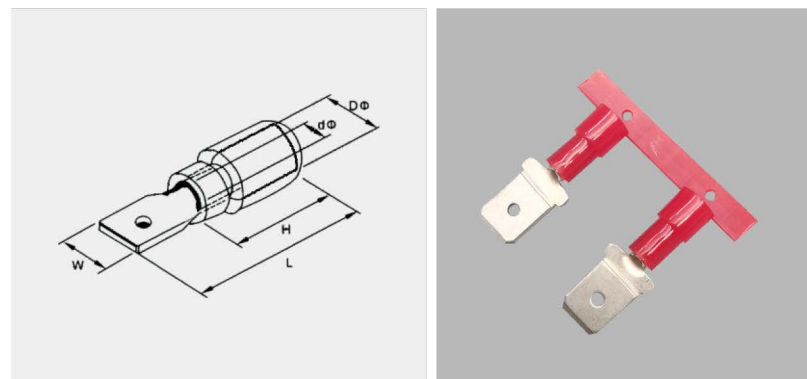

型号 Item NO	导线截面mm ² Cable Size A.W.G	最大电流 Max Current	接插规格 Connecting spec.	材料厚度 Thickness (mm)	尺寸 Dimension(mm)					颜色 Color
					W	Dφ	dφ	L	H	
MDD 2-187(5)	1.5~2.5 (16~14)	15A	0.5 × 4.75	0.5	4.75	4.3	2.3	20.0	11.0	蓝 blue
MDD 2-187(8)			0.8 × 4.75	0.8						
MDD 2-250			0.8 × 6.35	0.8						

型号 Item NO	导线截面mm ² Cable Size A.W.G	最大电流 Max Current	接插规格 Connecting spec.	材料厚度 Thickness (mm)	尺寸 Dimension(mm)					颜色 Color
					W	Dφ	dφ	L	H	
MDD 5.5-250	4-6 (12~10)	24A	0.8 × 6.35	0.8	6.35	6.6	3.4	25.0	14.0	黄 yellow

连续预绝缘母端

(适用于软线)

Continuous Preinsulation Female Terminal
(Apply in flexible wire)

材质: 黄铜 Terminal Body: Brass
护套: 尼龙、PC Insulation: Nylon、PC
温度: 105°C、115°C Temperature: 105°C、115°C
表面处理: 镀锡 Plating: Tin

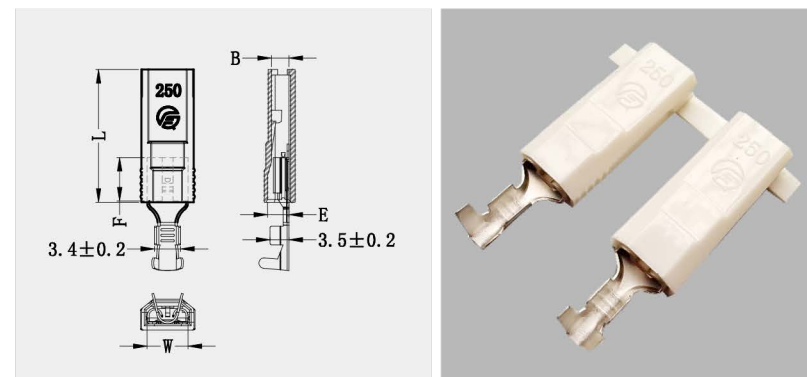

型号 Item NO	导线截面mm ² Cable Size A.W.G	最大电流 Max Current	五金材料厚度 Thickness (mm)	尺寸 Dimension(mm)				
				W	L	F	B	E
STNY1.5-250	0.5-2.5(20-14)	10A	0.4	7.5	24.3	7.8	3.2	4.0

连续预绝缘带锁

(适用于软线)

Continuous Preinsulation With Lock
(Apply in flexible wire)

材质: 黄铜 Terminal Body: Brass
护套: 尼龙、PC Insulation: Nylon、PC
温度: 105°C、115°C Temperature: 105°C、115°C
表面处理: 镀锡 Plating: Tin

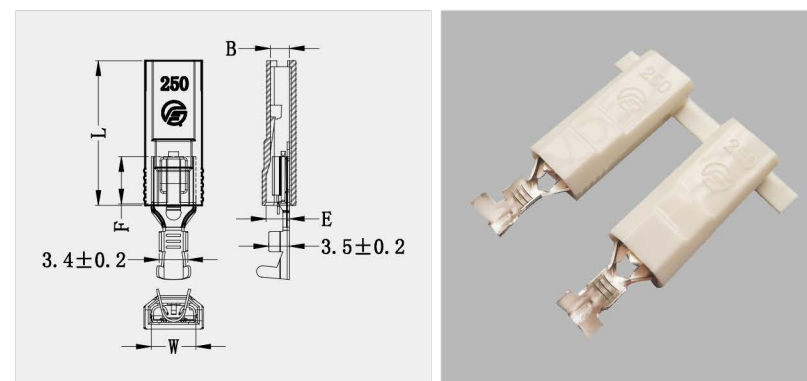

型号 Item NO	导线截面mm ² Cable Size A.W.G	最大电流 Max Current	五金材料厚度 Thickness (mm)	尺寸 Dimension(mm)				
				W	L	F	B	E
LTNY1.5-250	0.5-2.5(20-14)	10A	0.4	7.5	24.3	7.8	3.2	4.0

尼龙绝缘护套母插端子(椭圆口)

(适用于软线)

Nylon-Insulated Female Terminal
(apply In Flexible Wire)

材质: 黄铜 Terminal Body: Brass
护套: 尼龙 Insulation: Nylon
温度: 105°C Temperature: 105°C
表面处理: 镀锡 Plating: Tin

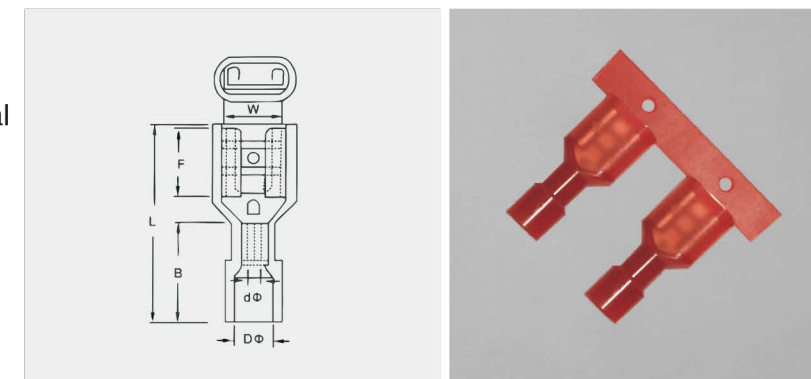

型号 Item NO	导线截面mm ² Cable Size A.W.G	最大电流 Max Current	接插规格 Connecting spec.	材料厚度 Thickness (mm)	尺寸 Dimension(mm)					颜色 Color
					W	F	L	B	Dφ	
FDNF 1.25-250-T	0.5-1.5 (22~16)	10A	0.8 × 6.35	0.4	7.6	7.6	22.0	10.8	3.6	红 red
FDNF 2-250-T	1.5-2.5 (16~14)	15A	0.8 × 6.35	0.4	7.6	7.6	22.0	10	4.8	2.3 蓝 blue

尼龙绝缘护套母插端子(方口)

(适用于软线)

Nylon-Insulated Female Terminal
(apply In Flexible Wire)

材质: 黄铜 Terminal Body: Brass
护套: 尼龙 Insulation: Nylon
温度: 105°C Temperature: 105°C
表面处理: 镀锡 Plating: Tin

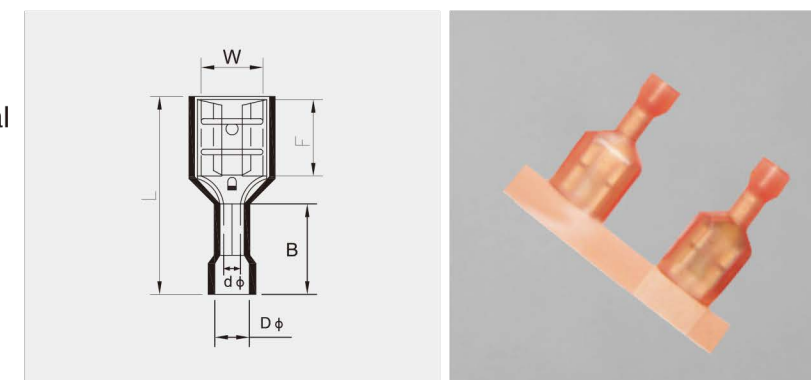

型号 Item NO	导线截面mm ² Cable Size A.W.G	最大电流 Max Current	接插规格 Connecting spec.	材料厚度 Thickness (mm)	尺寸 Dimension(mm)					颜色 Color			
					W	F	L	B	Dφ		dφ		
FDNF 1.25-110(5)	0.5-1.5 (22~16)	10A	0.5 × 2.8	0.3	4.0	6.4	18.7	9.0	3.1	1.7 红 red			
FDNF 1.25-110(8)			0.8 × 2.8	0.3									
FDNF 1.25-187(5)			0.5 × 4.75	0.35									
FDNF 1.25-187(8)			0.8 × 4.75	0.35									
FDNF 1.25-250	1.5-2.5 (16~14)	15A	0.8 × 6.35	0.4	7.6	7.6	21.2	10.0	3.6	2.3 蓝 blue			
FDNF 2-110(5)			0.5 × 2.8	0.3									
FDNF 2-110(8)			0.8 × 2.8	0.3									
FDNF 2-187(5)			0.8 × 4.75	0.35									
FDNF 2-187(8)			0.8 × 4.75	0.35									
FDNF 2-250			0.8 × 6.35	0.4									
FDNF 5.5-250			4-6 (12~10)	24A	0.8 × 6.35	0.45	7.6	7.6	23.2		12.6	8.5	3.4 黄 yellow

尼龙绝缘护套母插端子(双线)

(适用于软线)

Nylon-Insulated Female Terminal
(apply In Flexible Wire)

材质: 黄铜 Terminal Body: Brass
护套: 尼龙 Insulation: Nylon
温度: 105°C Temperature: 105°C
表面处理: 镀锡 Plating: Tin

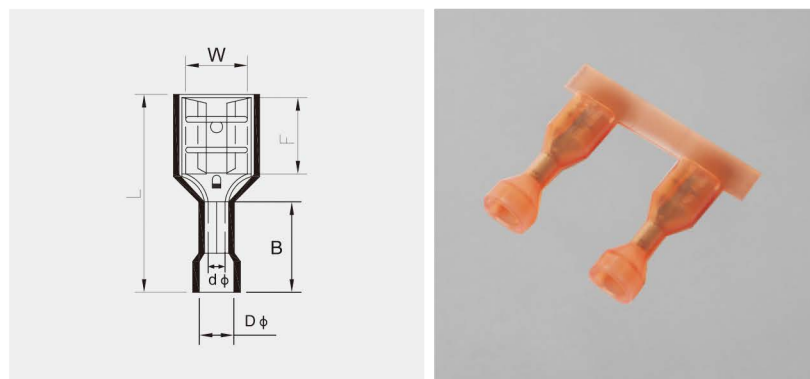

型号 Item NO	导线截面mm ² Cable Size A.W.G	最大电流 Max Current	接插规格 Connecting spec.	材料厚度 Thickness (mm)	尺寸 Dimension(mm)						颜色 Color
					W	F	L	B	Dφ	dφ	
FDFN 1.25-110(5)-2	0.5~1.5 (22~16)	10A	0.5 × 2.8	0.3	4.0	6.4	19.0	12	6.1	1.7	红 red
FDFN 1.25-110(8)-2			0.8 × 2.8	0.3	4.0	6.4	19.0	12	6.1		
FDFN 1.25-187(5)-2			0.5 × 4.75	0.35	5.9	6.4	23.8	12	6.1		
FDFN 1.25-187(8)-2			0.8 × 4.75	0.35	5.9	6.4	23.8	12	6.1		
FDFN 1.25-250 -2			0.8 × 6.35	0.4	7.6	7.6	24.0	13	6.0		

型号 Item NO	导线截面mm ² Cable Size A.W.G	最大电流 Max Current	接插规格 Connecting spec.	材料厚度 Thickness (mm)	尺寸 Dimension(mm)						颜色 Color
					W	F	L	B	Dφ	dφ	
FDFN 2-187(5)-2	1.5~2.5 (16~14)	15A	0.5 × 4.75	0.35	5.9	6.4	23.8	12	6.8	2.3	蓝 blue
FDFN 2-187(8)-2			0.8 × 4.75	0.35	5.9	6.4	23.8	12	6.8	2.3	
FDFN 2-250 -2			0.8 × 6.35	0.4	7.6	7.6	21.2	10	6.7	2.3	

尼龙全绝缘护套公插端子(椭圆口)

(适用于软线)

Nylon-Insulated male Terminal
(apply In Flexible Wire)

材质: 黄铜 Terminal Body: Brass
护套: 尼龙 Insulation: Nylon
温度: 105°C Temperature: 105°C
表面处理: 镀锡 Plating: Tin

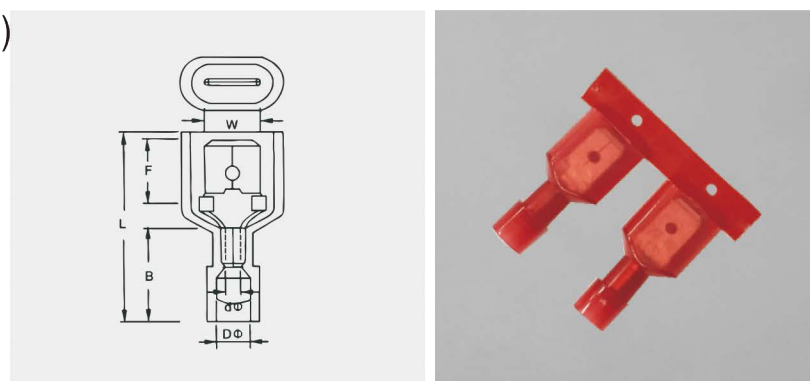

型号 Item NO	导线截面mm ² Cable Size A.W.G	最大电流 Max Current	接插规格 Connecting spec.	材料厚度 Thickness (mm)	尺寸 Dimension(mm)						颜色 Color
					W	F	L	B	Dφ	dφ	
MDFN 1.25-250-T	0.5~1.5 (22~16)	10A	0.8x6.35	0.8	6.35	8.6	24	12.5	3.9	1.7	红 red

型号 Item NO	导线截面mm ² Cable Size A.W.G	最大电流 Max Current	接插规格 Connecting spec.	材料厚度 Thickness (mm)	尺寸 Dimension(mm)						颜色 Color
					W	F	L	B	Dφ	dφ	
MDFN2-250-T	1.5~2.5 (16~14)	15A	0.8x6.35	0.8	6.35	7.7	24.5	11.0	4.5	2.3	蓝 blue

型号 Item NO	导线截面mm ² Cable Size A.W.G	最大电流 Max Current	接插规格 Connecting spec.	材料厚度 Thickness (mm)	尺寸 Dimension(mm)						颜色 Color
					W	F	L	B	Dφ	dφ	
MDFN5.5-250-T	4~6 (12~10)	24A	0.8x6.35	0.8	6.35	7.7	25.5	13.0	6.5	3.4	黄 yellow

尼龙全绝缘护套公插端子(双线)

(适用于软线)

Nylon-Insulated male Terminal
(apply In Flexible Wire)

材质: 黄铜 Terminal Body: Brass
护套: 尼龙 Insulation: Nylon
温度: 105°C Temperature: 105°C
表面处理: 镀锡 Plating: Tin

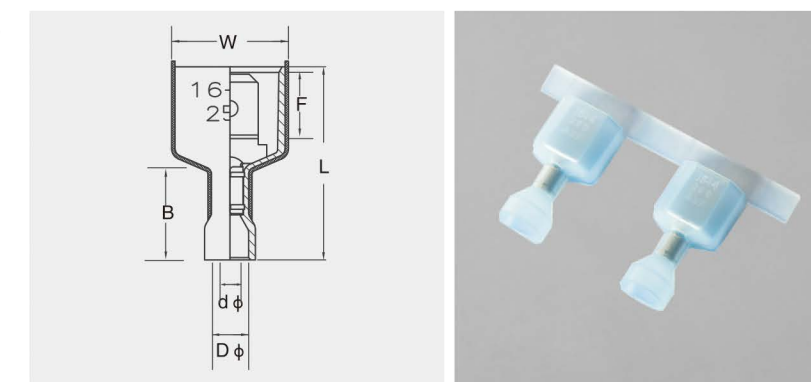

型号 Item NO	导线截面mm ² Cable Size A.W.G	最大电流 Max Current	接插规格 Connecting spec.	材料厚度 Thickness (mm)	尺寸 Dimension(mm)						颜色 Color
					W	F	L	B	Dφ	dφ	
MDFN 1.25-187(5)-2	0.5~1.5 (22~16)	10A	0.5x4.8	0.5	10.4	6.3	20.4	10.0	6.1	1.7	红 red
MDFN 1.25-187(8)-2	0.5~1.5 (22~16)	10A	0.8x4.8	0.8	10.4	6.3	20.4	10.0	6.1	1.7	
MDFN 1.25-250-2	0.5~1.5 (22~16)	10A	0.8x6.35	0.8	12.5	8.6	24	12	6.0	1.7	

型号 Item NO	导线截面mm ² Cable Size A.W.G	最大电流 Max Current	接插规格 Connecting spec.	材料厚度 Thickness (mm)	尺寸 Dimension(mm)						颜色 Color
					W	F	L	B	Dφ	dφ	
MDFN 2-187(5)-2	1.5~2.5 (16~14)	15A	0.5x4.8	0.5	10.4	6.3	20.4	10.0	6.8	2.3	蓝 blue
MDFN 2-187(8)-2	1.5~2.5 (16~14)	15A	0.8x4.8	0.8	10.4	6.3	20.4	10.0	6.8	2.3	
MDFN 2-250-2	1.5~2.5 (16~14)	15A	0.8x6.35	0.8	12.3	7.7	21.8	10.0	6.8	2.3	

尼龙全绝缘护套公插端子(方口)

(适用于软线)

Nylon-Insulated male Terminal
(apply In Flexible Wire)

材质: 黄铜 Terminal Body: Brass
护套: 尼龙 Insulation: Nylon
温度: 105°C Temperature: 105°C
表面处理: 镀锡 Plating: Tin

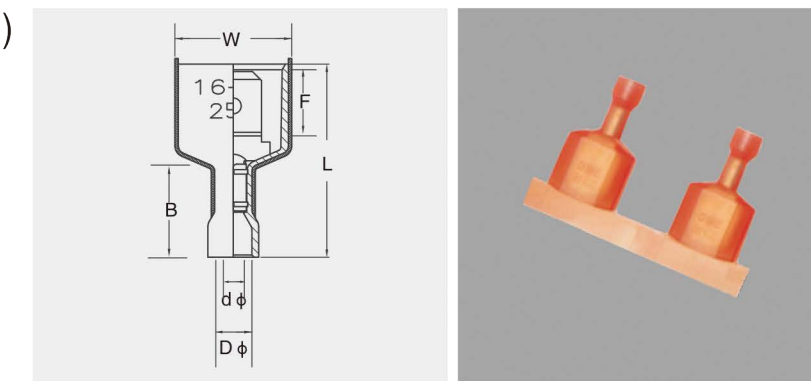

型号 Item NO	导线截面mm ² Cable Size A.W.G	最大电流 Max Current	接插规格 Connecting spec.	材料厚度 Thickness (mm)	尺寸 Dimension(mm)						颜色 Color
					W	F	L	B	Dφ	dφ	
MDFN 1.25-187(5)	0.5~1.5 (22~16)	10A	0.5x4.8	0.5	10.4	6.8	20.4	9.6	3.6	1.7	红 red
MDFN 1.25-187(8)	0.5~1.5 (22~16)	10A	0.8x4.8	0.8	10.4	6.8	20.4	9.6	3.6	1.7	
MDFN 1.25-250	0.5~1.5 (22~16)	10A	0.8x6.35	0.8	12.3	8.6	22	9.8	3.6	1.7	

型号 Item NO	导线截面mm ² Cable Size A.W.G	最大电流 Max Current	接插规格 Connecting spec.	材料厚度 Thickness (mm)	尺寸 Dimension(mm)						颜色 Color
					W	F	L	B	Dφ	dφ	
MDFN2-187(5)	1.5~2.5 (16~14)	15A	0.5x4.8	0.5	10.4	6.3	20.4	10.0	4.3	2.3	蓝 blue
MDFN2-187(8)	1.5~2.5 (16~14)	15A	0.8x4.8	0.8	10.4	6.3	20.4	10.0	4.3	2.3	
MDFN2-250	1.5~2.5 (16~14)	15A	0.8x6.35	0.8	12.4	8.6	22	10.0	4.5	2.3	

型号 Item NO	导线截面mm ² Cable Size A.W.G	最大电流 Max Current	接插规格 Connecting spec.	材料厚度 Thickness (mm)	尺寸 Dimension(mm)						颜色 Color
					W	F	L	B	Dφ	dφ	
MDFN5.5-250	4~6 (12~10)	24A	0.8x6.35	0.8	12.3	7.7	21.8	10.0	6.5	3.4	黄 yellow

尼龙全绝缘护套旗形母插端子

(适用于软线)

Nylon-Flag Female Insulated Joint Terminal
(apply In Flexible Wire)

材质: 黄铜 Terminal Body: Brass
护套: 尼龙 Insulation: Nylon
温度: 105°C Temperature: 105°C
表面处理: 镀锡 Plating: Tin

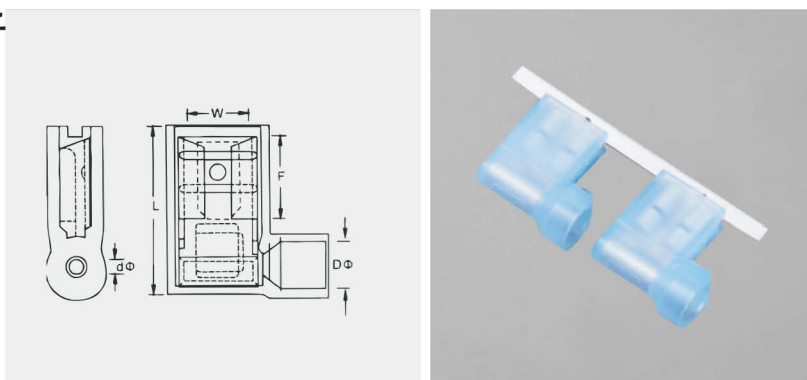

型号 Item NO	导线截面mm ² Cable Size A.W.G	最大电流 Max Current	接插规格 Connecting spec.	材料厚度 Thickness (mm)	尺寸 Dimension(mm)					颜色 Color
					W	F	L	Dφ	dφ	
FLDNY1.25-187(5)	0.5~1.5 (22~16)	10A	0.5x4.8	0.4	5.8	6.9	15.4	4.6	1.7	红 red
FLDNY1.25-187(8)	0.5~1.5 (22~16)	10A	0.8x4.8	0.4	5.8	6.9	15.4	4.6	1.7	
FLDNY1.25-250	0.5~1.5 (22~16)	10A	0.8x6.35	0.4	7.64	7.6	15.4	4.6	1.7	
FLDNY1.25-250-2	0.5~1.5 (22~16)	10A	0.8x6.35	0.4	7.64	7.6	15.4	6.0	1.7	

型号 Item NO	导线截面mm ² Cable Size A.W.G	最大电流 Max Current	接插规格 Connecting spec.	材料厚度 Thickness (mm)	尺寸 Dimension(mm)					颜色 Color
					W	F	L	Dφ	dφ	
FLDNY2-187(5)	1.5~2.5 (16~14)	15A	0.5x4.8	0.4	5.8	7.0	15.4	5.3	2.3	蓝 blue
FLDNY2-187(8)	1.5~2.5 (16~14)	15A	0.8x4.8	0.4	5.8	7.0	15.4	5.3	2.3	
FLDNY2-250	1.5~2.5 (16~14)	15A	0.8x6.35	0.4	7.6	7.6	15.4	5.3	2.3	
FLDNY2-250-2	1.5~2.5 (16~14)	15A	0.8x6.35	0.4	7.6	7.6	15.4	6.0	2.3	

绝缘护套子弹形公插端子

(适用于软线)

Insulated Male Terminal
(apply In Flexible Wire)

材质: 黄铜 Terminal Body: Brass
护套: 尼龙、PC Insulation: Nylon、PC
温度: 105°C、115°C Temperature: 105°C、115°C
表面处理: 镀锡 Plating: Tin

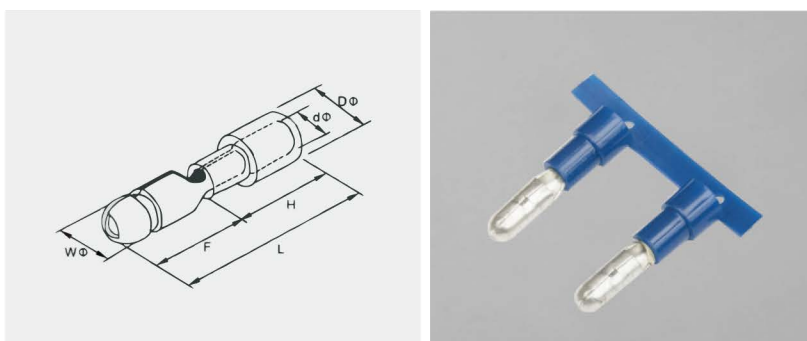

型号 Item NO	导线截面mm ² Cable Size A.W.G	最大电流 Max Current	材料厚度 Thickness (mm)	尺寸 Dimension(mm)					颜色 Color	
				Wφ	F	H	L	Dφ		dφ
MPD1.25-156	0.5~1.5 (22~16)	10A	0.4	4.0	11.5	11.6	23.0	4.3	1.8	红 red

型号 Item NO	导线截面mm ² Cable Size A.W.G	最大电流 Max Current	材料厚度 Thickness (mm)	尺寸 Dimension(mm)					颜色 Color	
				W	F	H	L	Dφ		dφ
MPD2-156	1.5~2.5 (16~14)	15A	0.4	4.0	12.0	11.6	23.6	4.3	2.3	蓝 blue

尼龙全绝缘护套子弹形母插端子

(适用于软线)

Nylon- Fully Insulated female bullet receptacle
(apply In Flexible Wire)

材质: 黄铜 Terminal Body: Brass
护套: 尼龙 Insulation: Nylon
温度: 105°C Temperature: 105°C
表面处理: 镀锡 Plating: Tin

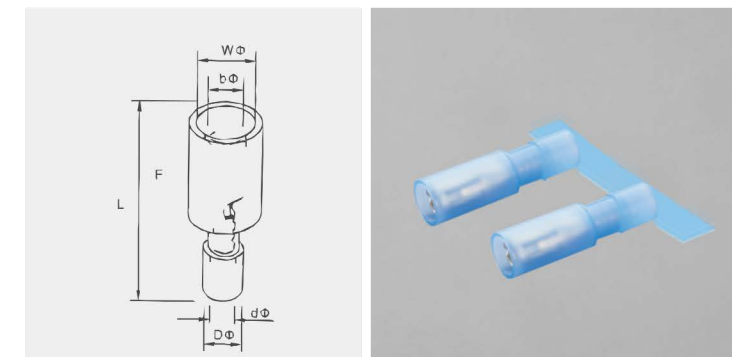

型号 Item NO	导线截面mm ² Cable Size A.W.G	最大电流 Max Current	材料厚度 Thickness (mm)	尺寸 Dimension(mm)					颜色 Color	
				Wφ	bφ	Dφ	dφ	L		F
FRFNY1.25-156	0.5~1.5 (22~16)	15A	0.4	5.5	3.9	4.3	1.8	24.5	14	红 red
FRFNY2-156	1.5~2.5 (16~14)	24A	0.4	5.6	3.9	4.2	2.4	24.5	14	蓝 blue

尼龙全绝缘护套子弹形公插端子

(适用于软线)

Nylon- Fully Insulated Male bullet receptacle
(apply In Flexible Wire)

材质: 黄铜 Terminal Body: Brass
护套: 尼龙 Insulation: Nylon
温度: 105°C Temperature: 105°C
表面处理: 镀锡 Plating: Tin

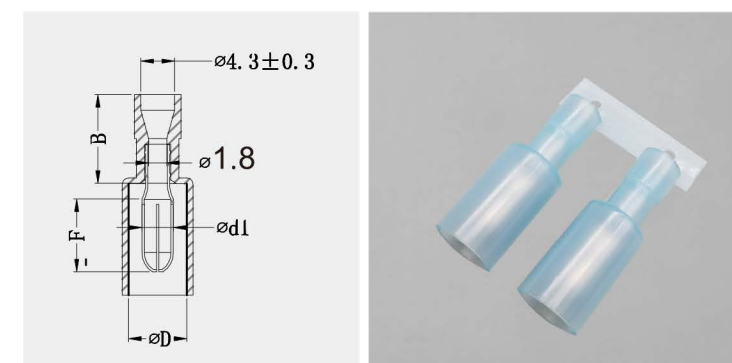

型号 Item NO	导线截面mm ² Cable Size A.W.G	最大电流 Max Current	材料厚度 Thickness (mm)	尺寸 Dimension(mm)					颜色 Color	
				Wφ	bφ	Dφ	dφ	L		F
MRFNY1.25-156	0.5~1.5 (22~16)	10A	0.4	7.5	3.9	4.3	1.8	25.5	9.5	红 red
MRFNY2-156	1.5~2.5 (16~14)	15A	0.4	7.5	3.9	4.3	2.3	25.5	9.2	蓝 blue

接线帽

材质 Material

内部套管由铜(铝)镀锡制成, 外部采用UL认证之尼龙PA66
Tin-coated copper (AL) piece covered by UL Approved nylon66

用途 How to use

电器制品之优良接线器。
Excellent connector for electric products.

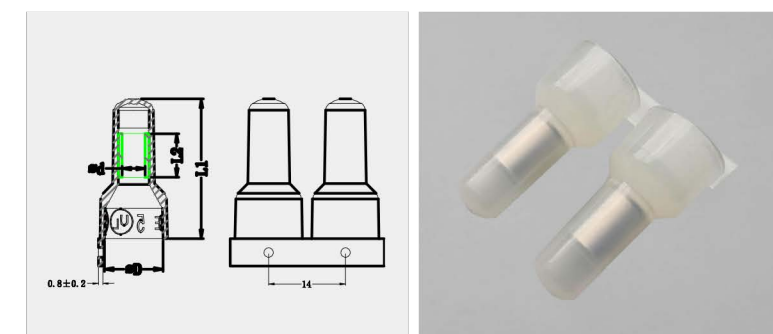

型号 Item NO	套管材质 Material	导线截面 Cable Size A.W.G	mm ²	主要尺寸 Dimension(mm)			
				L1±0.3	L2±0.3	∅D±0.3	∅d±0.3
CE1 I	紫铜 Copper	22-16	0.5-1.5	18	6.9	6.0	2.5
CE2 I	紫铜 Copper	16-14	1.5-2.5	20	7.0	8.0	3.0
CE5 I	紫铜 Copper	12-10	4-6	25.5	8.0	10.6	4.3
CE1 X	铝 Aluminium	22-16	0.5-1.5	18	6.9	6.0	2.5
CE2 X	铝 Aluminium	16-14	1.5-2.5	20	7.0	8.0	3.0
CE5 X	铝 Aluminium	12-10	4-6	25.5	8.0	10.6	4.3

尼龙绝缘护套管形端子

(适用于软线)

Nylon-Insulated Cord End terminal
(apply In Flexible Wire)

材质: 紫铜 Terminal Body: Copper
 护套: 尼龙 Insulation: Nylon
 温度: 105°C Temperature: 105°C
 表面处理: 镀锡 Plating: Tin

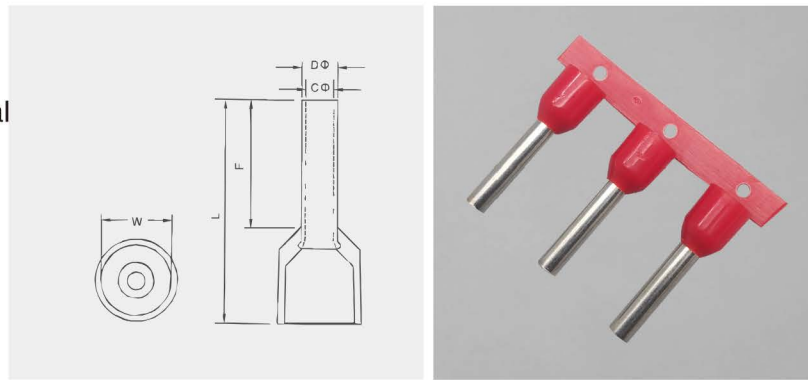

型号 Item NO	尺寸 Dimension(mm)					导线截面mm ² A.W.G	Cable Size mm ²	颜色Color	
	H	L	W	Dφ	Cφ			德国 Germany	法国用France
EVN0306	6.0	9.8	1.9	1.1	0.8	#24	0.3	浅蓝色 Light blue	粉色 Pink
EVN0308	8.0	11.8							
EVN0310	10.0	13.8							
EVN0506	6.0	12.0	2.7	1.3	1.0	#22	0.5	橙色 Orange	白色 White
EVN0508	8.0	14.0							
EVN0510	10.0	16.0							
EVN0512	12.0	18.0	2.85	1.6	1.27	#20	0.75	白色 White	蓝色 blue
EVN7506	6.0	12.4							
EVN7508	8.0	14.4							
EVN7510	10.0	16.4							
EVN7512	12.0	18.4	3.3	1.8	1.5	#18	1.0	黄色 yellow	红色 Red
EVN1006	6.0	12.6							
EVN1008	8.0	14.6							
EVN1010	10.0	16.6							
EVN1012	12.0	18.6	3.7	2.1	1.82	#16	1.5	红色 Red	黑色 Black
EVN1508	8.0	15							
EVN1510	10.0	17							
EVN1512	12.0	19							
EVN1518	18.0	24	4.3	2.6	2.3	#14	2.5	蓝色 blue	灰色 gray
EVN2508	8.0	15.0							
EVN2510	10.0	17.0							
EVN2512	12.0	19.0							
EVN2518	18.0	25.0	4.8	3.3	2.9	#12	4.0	灰色 gray	橙色 Orange
EVN4009	9.0	17.0							
EVN4012	12.0	20.0							
EVN4018	18.0	26.0							
EVN6010	10.0	19	6.0	3.95	3.65	#10	6.0	黑色 Black	绿色 Green
EVN6012	12.0	21							
EVN6018	18.0	27							
EVN10-12 (没有UL)	12.0	23.2	7.8	4.9	4.5	#7	10.0	乳白色 milky	
EVN10-18 (没有UL)	18.0	29.2							

连续端子

CONTINUOUS PRESSED TERMINALS



连续端子产品描述

CONTINUOUS PRESSED TERMINALS DESCRIPTION ON PRODUCTS

产品代号	产品类型	PRODUCTS TYPE
R	圆形端子	RING TERMINAL
Y	叉形端子	SPADE TERMINAL
S	插簧	PLUG SPRING
L	插簧锁扣	PLUG SPRINGLOCK
F	旗形插簧	FLAG PLUG SPRING
W	包线端子	COVERED WIRE TERMINALS
N	管形端子	TUBE TYPE TERMINAL
NM	子弹母端	THE BULLET FEMALE TERMINAL
NP	子弹公端	THE BULLET MALE TERMINAL
T	碰焊端子	WELDING TERMINAL
RH	圆形太阳端止滑端	ROUND SUN END STOP SLIP TERMINAL
FS	旗形带锁端子	FLAG TERMINAL WITH LOCK

2.8直型母端 110"Terminals

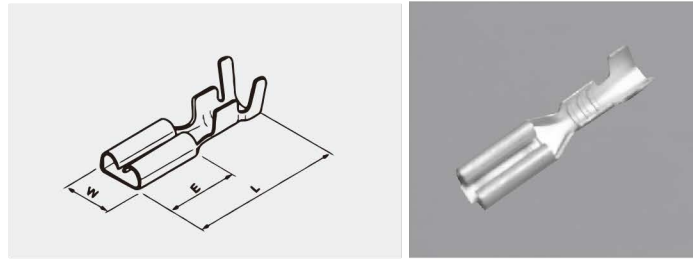

PartNo.型号	Material材质			MaterialThick-ness料厚(mm)	WireRang(AWG) 电线范围(线号)	TabThickness 公片厚度(mm)	Dimension尺寸(mm)			Packing 包装
							W	E	L	
ST110	01	銅	Brass	0.25	22-18 (0.33-0.89)	TAB=0.5/0.8	3.8	6.3	15.4	15K/R
	02	銅鍍錫	TinnedBrass							
	03	鐵鍍鎳	NickelSteel							
	04	銅鍍鎳	NickelBrass							
	09	中碳钢	medium carbon steel							
SS110	01	銅	Brass	0.25	22-24 (0.33-0.24)	TAB=0.5/0.8	3.8	6.3	15.4	15K/R
	02	銅鍍錫	TinnedBrass							
	03	鐵鍍鎳	NickelSteel							
	04	銅鍍鎳	NickelBrass							
	09	中碳钢	medium carbon steel							
SK11005	01	銅	Brass	0.25	22-18 (0.33-0.89)	0.5	4.0	6.3	15.4	5K/R
	02	銅鍍錫	TinnedBrass							
	03	鐵鍍鎳	TinnedCopper							

LW11005四方插母端 110"Square terminal

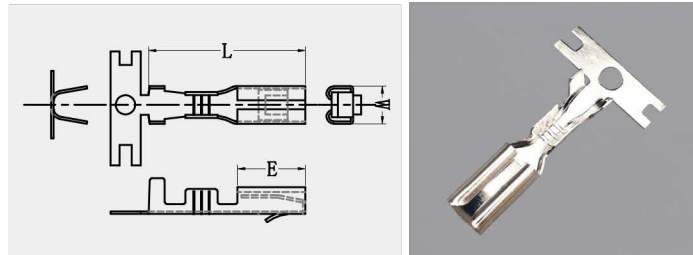

PartNo.型号	Material材质			MaterialThick-ness料厚(mm)	WireRang(AWG) 电线范围(线号)	TabThickness 公片厚度(mm)	Dimension尺寸(mm)			Packing 包装
							W	E	L	
LW1100	銅	Brass	0.25	18-22(0.83-0.33)	0.5	3.8	6.8	15.7	5K/R	

2.8直型带锁母端 110" Terminals

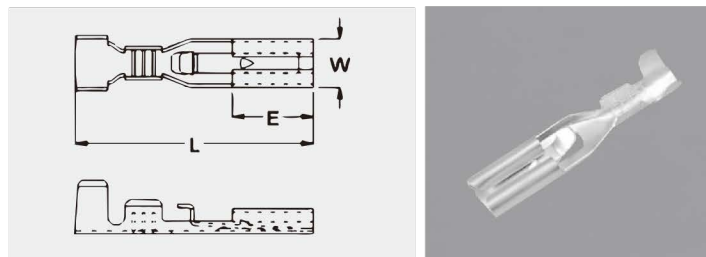

LT110	01	銅	Brass	0.25	18-22(0.83-0.33)	TAB=0.5/0.8	3.7	6.3	17.4	10K/R
	02	銅鍍錫	TinnedBrass							
Ls110	01	銅	Brass	0.25	22-24	TAB=0.5/0.8	3.7	6.0	17.3	15K/R
	02	銅鍍錫	TinnedBrass							

2.8旗型母端 110" Flag Terminals

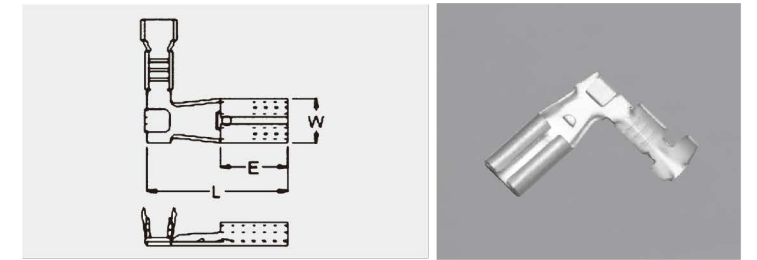

PartNo.型号	Material材质			MaterialThick-ness料厚(mm)	WireRang(AWG) 电线范围(线号)	TabThickness 公片厚度(mm)	Dimension尺寸(mm)			Packing 包装
							W	E	L	
FT110	01	銅	Brass	0.3	20-22	TAB=0.5/0.8	3.8	4.9	11.0	7000
	02	銅鍍錫	TinnedBrass							
FS110	01	銅	Brass	0.3	22-24	TAB=0.5/0.8	3.8	4.1	10.2	5000
	02	銅鍍錫	TinnedBrass							

2.8公端 110" Terminals

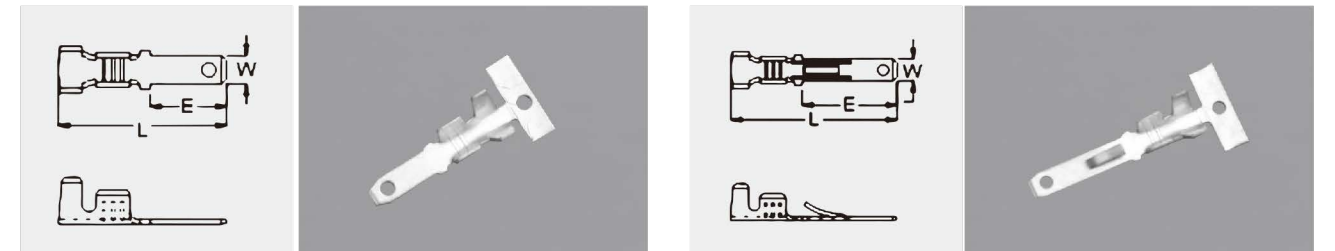

PartNo.型号	Material材质			MaterialThick-ness料厚(mm)	WireRang(AWG) 电线范围(线号)	TabThickness 公片厚度(mm)	Dimension尺寸(mm)			Packing 包装
							W	E	L	
TT110	01	銅	Brass	0.5/0.8	16-20	TAB=0.5/0.8	2.8	7.4	16.0	5/R
	02	銅鍍錫	TinnedBrass							
TL110	01	銅	Brass	0.5	18-22	TAB=0.5/0.8	2.8	12.0	21.0	5/R
	02	銅鍍錫	TinnedBrass							

2.8其它端子 110" Terminals

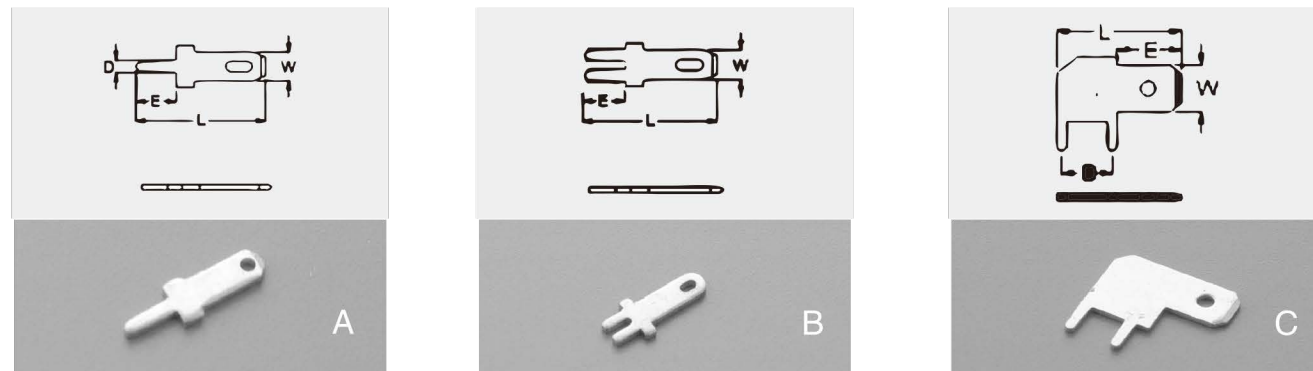

PartNo.型号	Material材质	MaterialThick-ness料厚(mm)	图号	TabThickness公片厚度(mm)	Dimension尺寸(mm)				Packing包装
					W	E	D	L	
PCB11001	01 铜 Brass	0.5	A	TAB=0.5/0.8	2.8	4.7	1.3	13.8	5K/B
	02 铜镀锡 TinnedBrass								
PCB11002	01 铜 Brass	0.5	B	TAB=0.5/0.8	2.8	3.2	1.1	13	5K/B
	02 铜镀锡 TinnedBrass								
PCB11003	01 铜 Brass	0.5	C	TAB=0.5/0.8	2.8	7.5	5.0	13.9	5K/B
	02 铜镀锡 TinnedBrass								
PCB11005	01 铜 Brass	0.5	C	TAB=0.5/0.8	2.8	3.6	4.0	9.2	5K/B
	02 铜镀锡 TinnedBrass								
PCB11008	01 铜 Brass	0.8	C	TAB=0.5/0.8	2.8	3.6	4.0	9.2	5K/B
	02 铜镀锡 TinnedBrass								

2.8直型软护套 110" Sleeves

料号 Part No.	Material 材质	颜色 Color	Dimension 尺寸 (mm)			Packing 包装
			W	L	D	
DR110-25	液态PVC	透明白	4.0	17.0	2.5	2000/包
DR110-25B		透明蓝				
DR110-30		透明白	4.0	17.0	3.0	
DR110-30B		透明蓝				

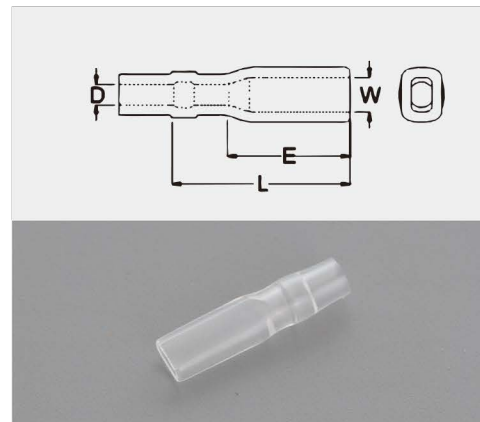

2.8直型硬护套 110" Sleeves

料号 Part No 型号	Material 材质	颜色 Color	Dimension 尺寸(mm)			Packing 包装
			W	L	H	
DFN110	尼龙PA66	透明本色	5	20	4	2000/包
DFN110-V0		防火V0本色				

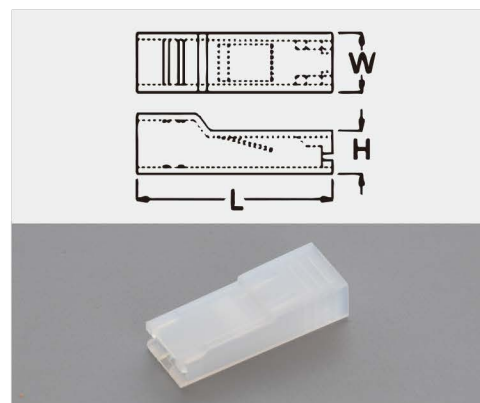

4.8直型端子 187" Terminals

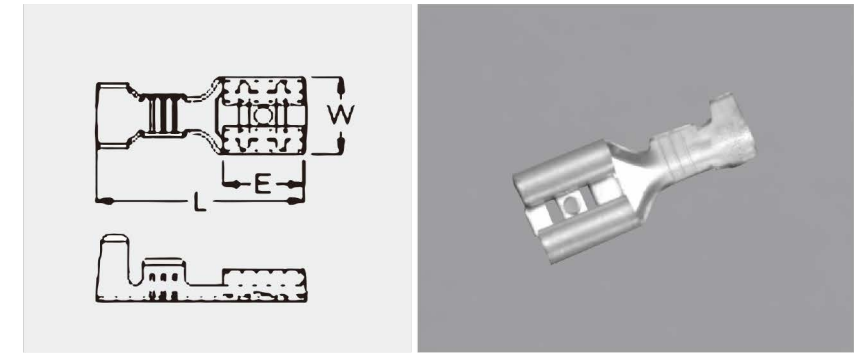

PartNo. 型号	Material 材质	Material Thickness 料厚(mm)	WireRang (AWG) 电线范围(线号)	Tab Thickness 公片厚度(mm)	Dimension 尺寸(mm)			Packing 包装
					W	E	L	
ST187	01 铜 Brass	0.3	18-22 (0.83-0.33)	TAB=0.5/0.8	5.6	6.35	15.0	10K/R
	02 铜镀锡 TinnedBrass							
	03 铁镀镍 NickelSteel							
	04 铜镀镍 NickelBrass							
ST187	09 中碳钢 medium carbon steel	0.4	18-22 (0.83-0.33)	TAB=0.5/0.8	5.9	6.3	15.1	10K/R
	01 铜 Brass	0.3						
	02 铜镀锡 TinnedBrass							
	03 铁镀镍 NickelSteel	0.35						
	04 铜镀镍 NickelBrass							
09 中碳钢 medium carbon steel								
SS187	01 铜 Brass	0.3	20-24 (0.52-0.24)	TAB=0.5/0.8	5.6	6.35	15.0	15K/R
	02 铜镀锡 TinnedBrass							
	03 铁镀镍 NickelSteel							
	04 铜镀镍 NickelBrass							
	09 中碳钢 medium carbon steel							
SL18705	01 铜 Brass	0.3	14-18 (2.0-0.83)	0.5	5.8	6.4	15.0	7K/R
	02 铜镀锡 TinnedBrass							
	03 铁镀镍 NickelSteel							
	04 铜镀镍 NickelBrass							
	09 中碳钢 medium carbon steel							
SL18708	01 铜 Brass	0.3	14-18 (2.0-0.83)	0.8	5.8	6.4	15.0	7K/R
	02 铜镀锡 TinnedBrass							
	03 铁镀镍 NickelSteel							
	04 铜镀镍 NickelBrass							
	09 中碳钢 medium carbon steel							

4.8直形带锁端子 187" Terminals

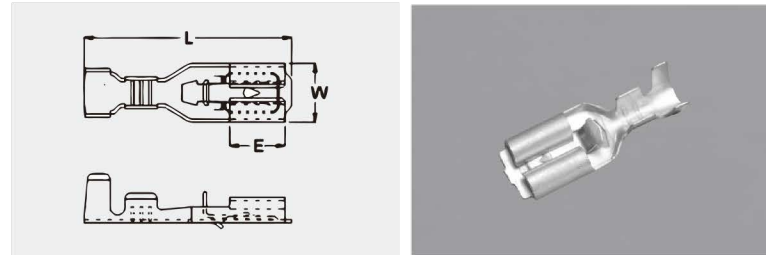

PartNo. 型号	Material 材质		Material Thickness 料厚(mm)	WireRang (AWG) 电线范围(线号)	Tab Thickness 公片厚度(mm)	Dimension 尺寸(mm)			Packing 包装
						W	E	L	
LT187	01	銅 Brass	0.3	18-22 (0.83-0.33)	TAB=0.5/0.8	5.5	6.5	17.5	7K/R
	02	銅鍍錫 TinnedBrass	0.35						
	03	鐵鍍鎳 NickelSteel							
	04	銅鍍鎳 NickelBrass							
LT18708	01	銅 Brass	0.35UL	18-22 (0.83-0.33)	0.8	5.7	5.0	19	7K/R
	02	銅鍍錫 TinnedBrass							
	03	鐵鍍鎳 NickelSteel							
	04	銅鍍鎳 NickelBrass							
	05								
LS18705	01	銅 Brass	0.30	20-24 (0.52-0.24)	0.5	5.5	6.5	17.5	7K/R
	02	銅鍍錫 TinnedBrass	0.35						
	03	鐵鍍鎳 NickelSteel	0.4						
	04	銅鍍鎳 NickelBrass							
LS18708	01	銅 Brass	0.30	20-24 (0.52-0.24)	0.8	5.5	6.5	17.5	7K/R
	02	銅鍍錫 TinnedBrass	0.35						
	03	鐵鍍鎳 NickelSteel	0.4						
	04	銅鍍鎳 NickelBrass							

4.8旗形端子 187" Flag Terminals

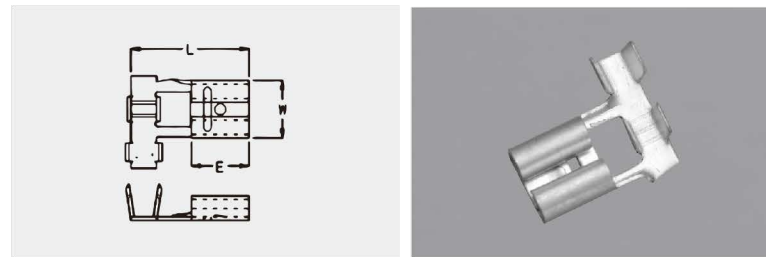

PartNo. 型号	Material 材质		Material Thickness 料厚(mm)	WireRang (AWG) 电线范围(线号)	Tab Thickness 公片厚度(mm)	Dimension 尺寸(mm)			Packing 包装
						W	E	L	
FT18705	01	銅 Brass	0.35	18-20 (0.83-0.52)	0.5	5.7	6.0	11.5	5K/R
	02	銅鍍錫 TinnedBrass	0.4						
	03	鐵鍍鎳 NickelSteel							
	04	銅鍍鎳 NickelBrass							
FT18708	01	銅 Brass	0.35	18-20 (0.83-0.52)	0.8	5.7	6.0	11.5	5K/R
	02	銅鍍錫 TinnedBrass	0.4						
	03	鐵鍍鎳 NickelSteel							
	04	銅鍍鎳 NickelBrass							
FL18705	01	銅 Brass	0.35	16-18 (1.31-0.83)	0.5	5.7	6.0	11.5	5K/R
	02	銅鍍錫 TinnedBrass	0.4						
	03	鐵鍍鎳 NickelSteel							
	04	銅鍍鎳 NickelBrass							
FL18708	01	銅 Brass	0.35	16-18 (1.31-0.83)	0.8	5.7	6.0	11.5	5K/R
	02	銅鍍錫 TinnedBrass	0.4						
	03	鐵鍍鎳 NickelSteel							
	04	銅鍍鎳 NickelBrass							

4.8旗形单边包线端子 187" Flag Terminals

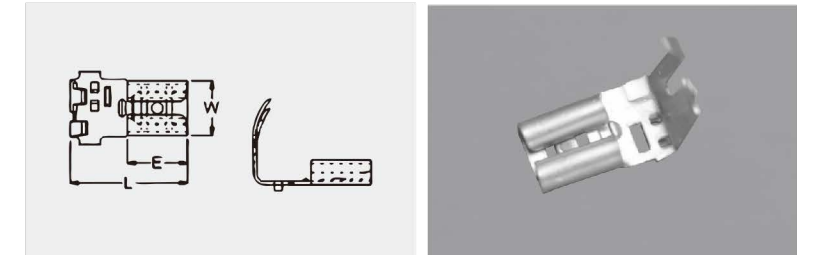

Part No. 型号	Material 材质		Material Thickness 料厚 (mm)	Wire Rang (AWG) 电线范围(线号)	Tab Thickness 公片厚度 (mm)	Dimension 尺寸 (mm)			Packing 包装
						W	E	L	
FST 187	01	銅 Brass	0.35	14 - 18 (0.83 - 0.52)	TAB=0.5/0.8	5.9	6.5	12.8	2.5K/R
	02	銅鍍錫 Tinned Brass							

4.8旗形带锁端子 187" Flag Terminals

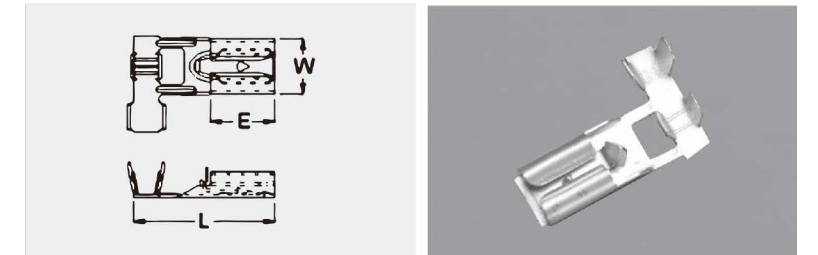

Part No. 型号	Material 材质		Material Thickness 料厚 (mm)	Wire Rang (AWG) 电线范围(线号)	Tab Thickness 公片厚度 (mm)	Dimension 尺寸 (mm)			Packing 包装
						W	E	L	
FKT 187	01	銅 Brass	0.3	18 - 20 (0.83 - 0.52)	TAB=0.5/0.8	5.6	6.3	14.5	5K/R
	02	銅鍍錫 Tinned Brass							

4.8旗形单边带锁系列 187" Flag Terminals

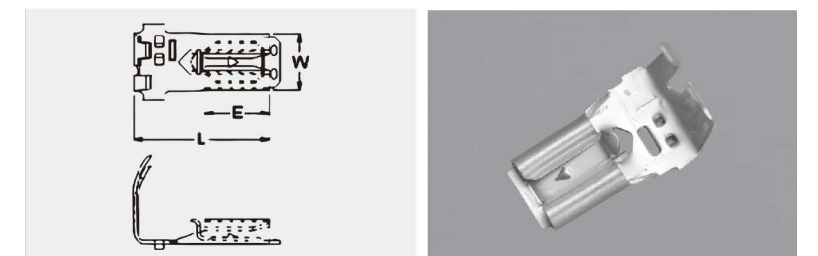

Part No. 型号	Material 材质		Material Thickness 料厚 (mm)	Wire Rang (AWG) 电线范围(线号)	Tab Thickness 公片厚度 (mm)	Dimension 尺寸 (mm)			Packing 包装
						W	E	L	
FSKT 187	01	銅 Brass	0.3	14- 18 (0.83 - 0.52)	TAB=0.5/0.8	5.8	6.5	16.1	2.5K/R
	02	銅鍍錫 Tinned Brass							

4.8公母一体端子 187" Terminals

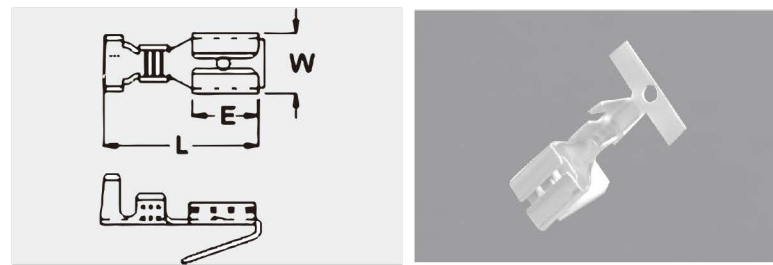

PartNo. 型号	Material 材质		Material Thickness 料厚(mm)	WireRang (AWG) 电线范围(线号)	Tab Thickness 公片厚度(mm)	Dimension 尺寸(mm)			Packing 包装
						W	E	L	
PG18705	01	銅	Brass	18-20 (0.83-0.52)	0.5	5.7	6.5	15.7	2K/R
	02	銅鍍錫	TinnedBrass						
	03	鐵鍍鎳	NickelSteel						
	04	銅鍍鎳	NickelBrass						
PG18708	01	銅	Brass	18-20 (0.83-0.52)	0.8	5.7	6.5	15.7	2K/R
	02	銅鍍錫	TinnedBrass						
	03	鐵鍍鎳	NickelSteel						
	04	銅鍍鎳	NickelBrass						
PG18705	01	銅	Brass	18-20 (0.83-0.52)	0.5	5.7	6.5	15.7	2K/R
	02	銅鍍錫	TinnedBrass						
	03	鐵鍍鎳	NickelSteel						
	04	銅鍍鎳	NickelBrass						
PG18708	01	銅	Brass	18-20 (0.83-0.52)	0.8	5.7	6.5	15.7	2K/R
	02	銅鍍錫	TinnedBrass						
	03	鐵鍍鎳	NickelSteel						
	04	銅鍍鎳	NickelBrass						

4.8直型公端 187" Male Terminals

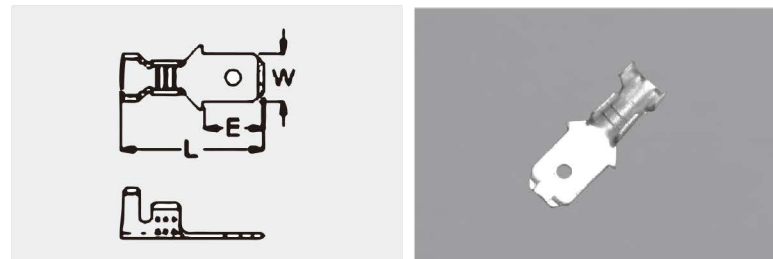

PartNo.型号	Material材质		Material Thickness 料厚(mm)	WireRang(AWG) 电线范围(线号)	TabThickness 公片厚度(mm)	Dimension尺寸(mm)			Packing 包装
						W	E	L	
TT18705UL	01	銅	0.5	16-22	TAB=0.5	4.8	6	14.5	7K/R
	02	銅鍍錫							
TT18708	01	銅	0.8	16-18	0.8	4.8	6	14.2	7K/R
	02	銅鍍錫							

4.8插片 187" Terminals

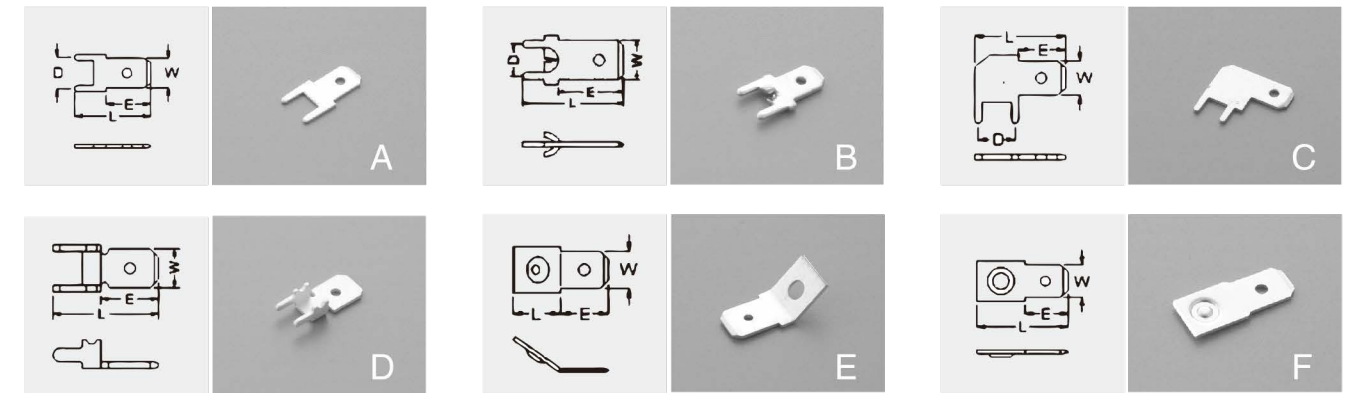

PartNo.型号	Material材质		MaterialThickness 料厚(mm)	图号	TabThickness 公片厚度(mm)	Dimension尺寸(mm)				Packing 包装
						W	E	D	L	
Cp187	01	銅	Brass	A	TAB=0.5/0.8	4.8	6.7	6.4	13	5K/B
	02	銅鍍錫	TinnedBrass							
Cp187防倒	01	銅	Brass	B	TAB=0.5/0.8	4.8	6.7	6.4	13	5K/B
	02	銅鍍錫	TinnedBrass							
Cf187	01	銅	Brass	C	TAB=0.5/0.8	4.8	6.3	5.2	14.2	5K/B
	02	銅鍍錫	TinnedBrass							
Ch187	01	銅	Brass	D	TAB=0.5/0.8	4.8	6.7		12.3	5K/B
	02	銅鍍錫	TinnedBrass							
18708垂插片	01	銅	Brass	E	TAB=0.5/0.8	4.8	6.4			5K/B
	02	銅鍍錫	TinnedBrass							
187肚脐插片	01	銅	Brass	F	TAB=0.5/0.8	4.8	6.3		14	5K/B
	02	銅鍍錫	TinnedBrass							

4.8直型软护套 187" Sleeves

料号 Part No.	Material 材质	颜色 Color	Dimension 尺寸 (mm)				Packing 包装
			W	E	L	D	
DR187-25	液态PVC	透明白	6.0	11.0	17.0	2.5	2000/包
DR187-25B		透明蓝					
DR187-30		透明白					
DR187-30B		透明蓝					
DR187-35	液态PVC	透明白	6.0	11.0	17.0	3.5	2000/包
DR187-35B		透明蓝					
DR187-40		透明白					
DR187-40B		透明蓝					
DR187-45	液态PVC	透明白	6.0	11.0	17.0	4.5	2000/包
DR187-45B		透明蓝					

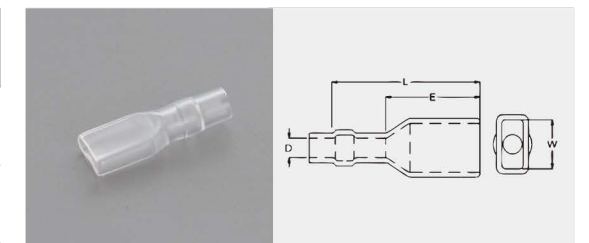

4.8直型倒穿软护套 187" Sleeves

料号 PartNo.	Material 材质	颜色 Color	Dimension 尺寸 (mm)				Packing 包装
			W	E	L	H	
DR187ES	液态PVC	透明白	6.0	7.0	23.0	2.6	2000/包
DR187ESB		透明蓝					

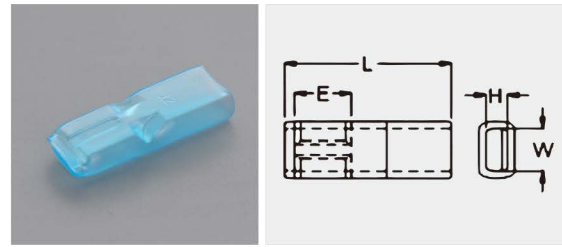

4.8旗型护套 187"flag Sleeves

料号 Part No.	Material 材质	颜色 Color	Dimension 尺寸 (mm)				Packing 包装
			W	E	L	D	
DF187	液态PVC	透明白	6.0	13.0	13.5	3.5	2000/包
DF187B		透明蓝					

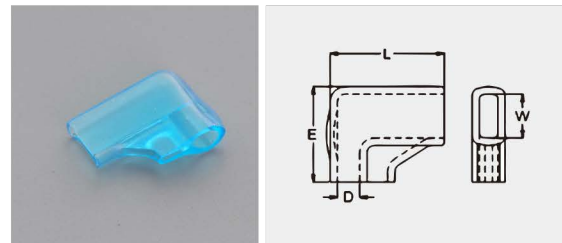

4.8直型硅胶护套 187" Sleeves

料号 Part No.	Material 材质	颜色 Color	Dimension 尺寸 (mm)				Packing 包装
			W	E	L	D	
DR187-V0R	阻燃硅胶	白色	6.0	13.0	19.0	4.4	2000/包
DR187-V0B		红色					

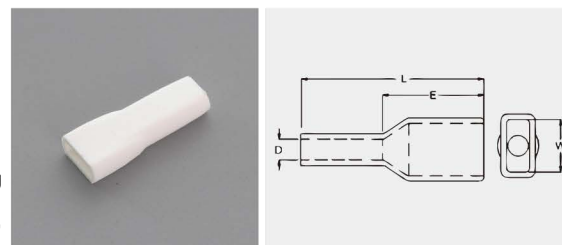

4.8旗型硅胶护套 187" Sleeves

料号 Part No.	Material 材质	颜色 Color	Dimension 尺寸 (mm)				Packing 包装
			W	E	L	D	
DF187-V0R	阻燃硅胶	白色	7.0	11.8	14.0	3.5	2000/包
DF187-V0B		红色					

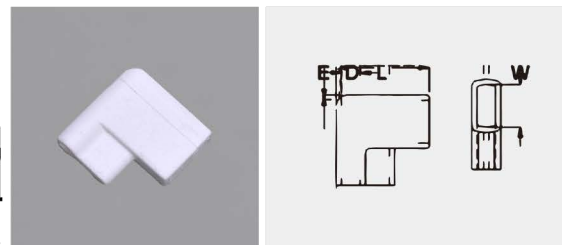

4.8直型硬护套 187" Sleeves

料号 Part No 型号	Material 材质	颜色 Color	Dimension 尺寸 (mm)				Packing 包装
			W	L	L1	H	
DRN187	尼龙PA66	透明本色	4.9	20.0		3.9	2000/包
DFN187-V0		防火V0本色					

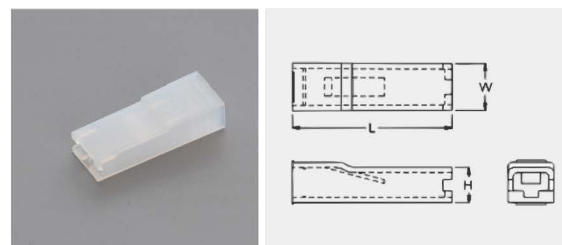

4.8旗型硬护套 187"flag Sleeves

料号 Part No 型号	Material 材质	颜色 Color	Dimension 尺寸 (mm)				Packing 包装
			W	L	L1	H	
DFN187-9	尼龙PA66	透明本色	5.5	10.5	13.6	15.5	1000/包
DFN187-9V0		防火V0本色					

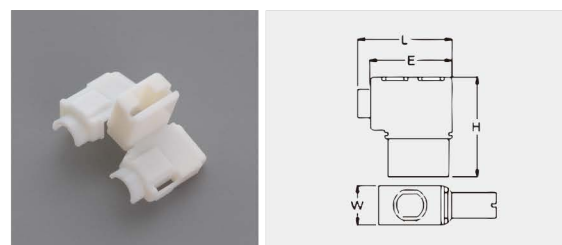

5.2直型母端 205" Terminals

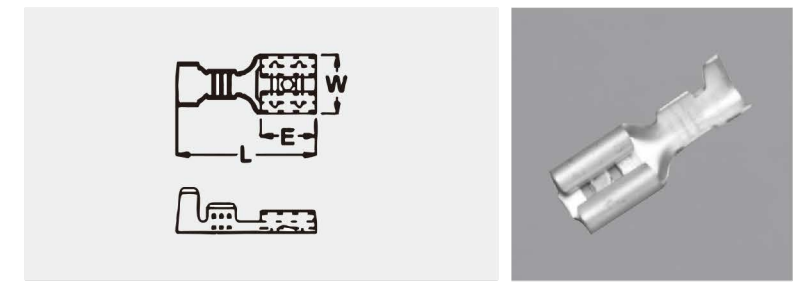

PartNo. 型号	Material 材质		Material Thickness 料厚 (mm)	WireRang (AWG) 电线范围 (线号)	Tab Thickness 公片厚度 (mm)	Dimension 尺寸 (mm)			Packing 包装
						W	E	L	
ST205	01	銅 Brass	0.3	18-22 (0.83-0.33)	TAB=0.5/0.8	6.4	6.4	15.4	7K/R
	02	銅鍍錫 TinnedBrass							
	03	鐵鍍鎳 NickelSteel							
	04	銅鍍鎳 NickelBrass							
SL20505	01	銅 Brass	0.3	14-18 (2.0-0.83)	0.5	6.1	6.4	15.0	7K/R
	02	銅鍍錫 TinnedBrass							
	03	鐵鍍鎳 NickelSteel							
	04	銅鍍鎳 NickelBrass							
	09	中碳钢 medium carbon steel							
SL20508	01	銅 Brass	0.3	14-18 (2.0-0.83)	0.8	6.1	6.4	15.0	7K/R
	02	銅鍍錫 TinnedBrass							
	03	鐵鍍鎳 NickelSteel							
	04	銅鍍鎳 NickelBrass							
	09	中碳钢 medium carbon steel							
Ss205	01	銅 Brass	0.3	24-22 (0.24-0.33)	TAB=0.5/0.8	6.4	6.4	15.4	7K/R
	02	銅鍍錫 TinnedBrass							
	03	鐵鍍鎳 NickelSteel							
	04	銅鍍鎳 NickelBrass							

5.2直型带锁母端 205" Terminals

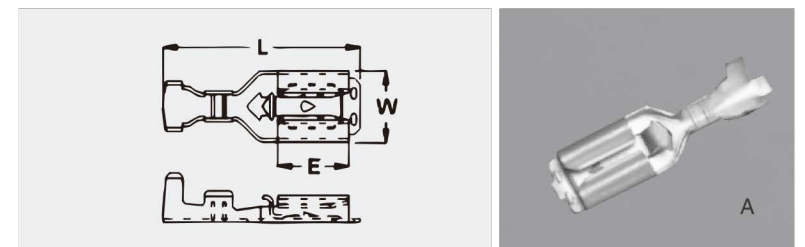

PartNo. 型号	Material 材质		Material Thickness 料厚 (mm)	WireRang (AWG) 电线范围 (线号)	Tab Thickness 公片厚度 (mm)	Dimension 尺寸 (mm)			Packing 包装
						W	E	L	
LT205	01	銅 Brass	0.3	18-22 (0.83-0.33)	TAB=0.5/0.8	6.5	6.0	17.5	7K/R
	02	銅鍍錫 TinnedBrass							
	03	鐵鍍鎳 NickelSteel							
	04	銅鍍鎳 NickelBrass							
	09	中碳钢 medium carbon steel							

5.2 旗形母端 205" Terminals

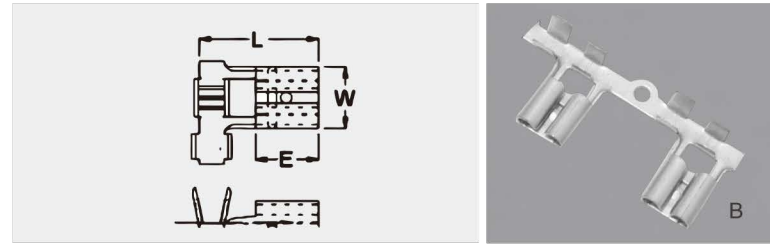

PartNo. 型号	Material 材质			Material Thickness 料厚(mm)	WireRang (AWG) 电线范围(线号)	Tab Thickness 公片厚度(mm)	Dimension 尺寸(mm)				Packing 包装
	01	02					W	E		L	
FT205	01 02	銅 銅鍍錫	Brass TinnedBrass	0.35	18-22	TAB=0.5/0.8	6.5	6.5		12.3	5K/R

5.2 直形软护套 205" Sleeves

料号 Part No.	Material 材质	颜色 Color	Dimension 尺寸 (mm)				Packing 包装
			W	E	L	D	
DR205-20	液态PVC	透明白	6.5	11.0	17.0	2.5	2000/包
DR205-20B		透明蓝					
DR205-25		透明白					
DR205-25B		透明蓝					
DR205-30		透明白					
DR205-30B		透明蓝					
DR205-35		透明白					
DR205-35B		透明蓝					

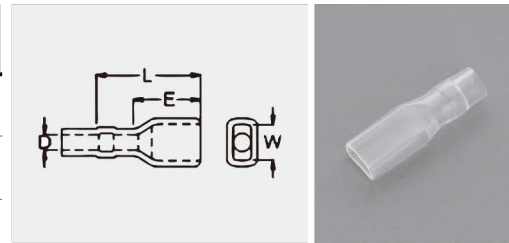

5.2 旗形软护套 205" Flag Sleeves

料号 Part No.	Material 材质	颜色 Color	Dimension 尺寸 (mm)				Packing 包装
			W	E	L	D	
DF205	液态PVC	透明白	7	14	13	3.5	2000/包
DF205B		透明蓝					

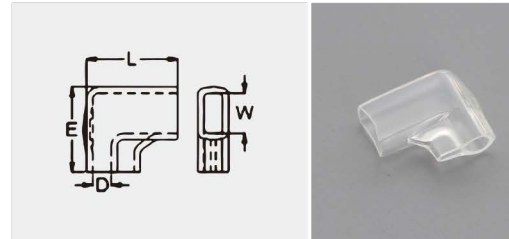

6.3 直型母端 250" Series Terminals

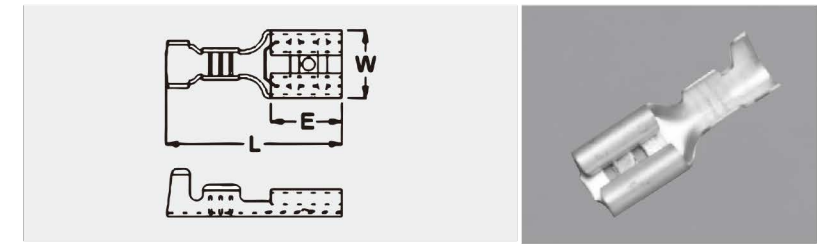

PartNo. 型号	Material 材质			Material Thickness 料厚(mm)	WireRang (AWG) 电线范围(线号)	Tab Thickness 公片厚度(mm)	Dimension 尺寸(mm)			Packing 包装
	01	02					W	E	L	
ST250	01	銅	Brass	TAB 0.35/0.4/0.5	16-20 (1.31-0.52)	TAB 0.5/0.8	7.6	7.6	19.5	5K/R
	02	銅鍍錫	TinnedBrass							
	03	鐵鍍鎳	NickelSteel							
	04	銅鍍鎳	NickelBrass							
	09	中碳钢	medium carbon steel							
ST250	01	銅	Brass	0.4UL	16-20 (1.31-0.52)	TAB0.8	7.6	7.6	19.5	5K/R
	02	銅鍍錫	TinnedBrass							
	03	鐵鍍鎳	NickelSteel							
	04	銅鍍鎳	NickelBrass							
	09	中碳钢	medium carbon steel							
SS250	01	銅	Brass	0.35	22-20 (0.33-0.52)	TAB 0.5/0.8	7.6	7.6	19.5	5K/R
	02	銅鍍錫	TinnedBrass							
	03	鐵鍍鎳	NickelSteel							
	04	銅鍍鎳	NickelBrass							
	09	中碳钢	medium carbon steel							
SL25008	01	銅	Brass	TAB 0.35/0.4/0.5	16-12 (1.31-3.3)	TAB0.8	7.5	7.8	19.5	4K/R
	02	銅鍍錫	TinnedBrass							
	03	鐵鍍鎳	NickelSteel							
	04	銅鍍鎳	NickelBrass							
	09	中碳钢	medium carbon steel							

6.3 直型母端 250" Series Terminals

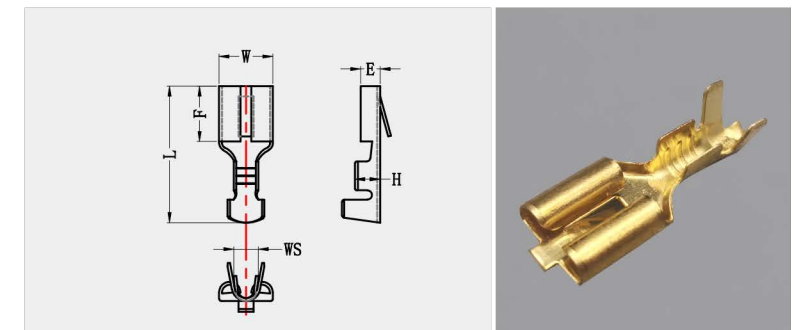

PartNo. 型号	Material 材质	Material Thickness 料厚(mm)	WireRang (AWG) 电线范围	Max Current 最大电流	Dimension 尺寸(mm)			Packing 包装
					L	W	F	
SK25008	黄銅 Brass	0.4	24-18 (0.2-0.75)	10A	19.0	7.5	7.5	5K

6.3直型带锁端子 250" Series Terminals

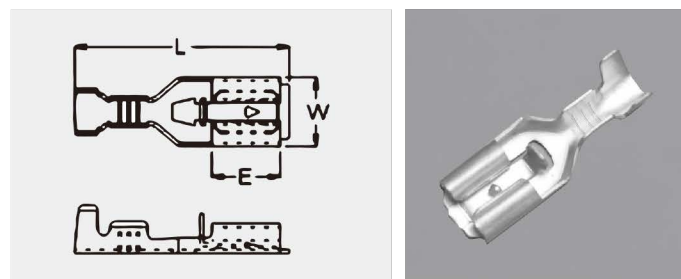

PartNo. 型号	Material 材质	Material Thickness 料厚(mm)	WireRang (AWG) 电线范围(线号)	Tab Thickness 公片厚度(mm)	Dimension 尺寸(mm)			Packing 包装
					W	E	L	
LT250	01 銅 Brass	0.35 0.4	18-22 (0.83-0.33)	0.8	7.5	6.5	19.0	4K/R
	02 銅鍍錫 TinnedBrass							
	03 鐵鍍鎳 NickelSteel							
	04 銅鍍鎳 NickelBrass							
	09							
LL250	01 銅 Brass	0.35 0.4	12-14 (4.0-2.5)	0.8	7.5	6.5	21.0	4K/R
	02 銅鍍錫 TinnedBrass							
	03 鐵鍍鎳 NickelSteel							
	04 銅鍍鎳 NickelBrass							
	05							
LS250	01 銅 Brass	0.35 0.4	20-24 (0.5-0.2)	0.8	7.5	6.5	21.0	4K/R
	02 銅鍍錫 TinnedBrass							
	03 鐵鍍鎳 NickelSteel							
	04 銅鍍鎳 NickelBrass							
	09							

6.3旗形端子 250" Flag Series Terminals

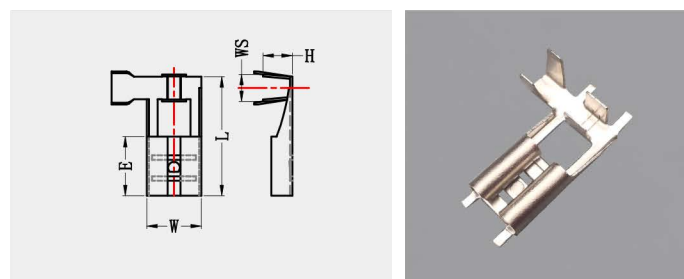

PartNo. 型号	Material 材质	Material Thickness 料厚(mm)	WireRang (AWG) 电线范围	Max Current 最大电流	Dimension 尺寸(mm)			Packing 包装
					L	W	E	
FUR25008	黃銅 Brass	0.35	22-16 (0.5-1.5)	10A	15.9	7.5	8.0	3K/R

6.3旗形端子 250" Flag Series Terminals

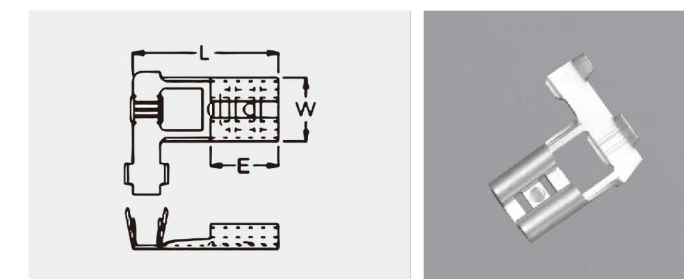

PartNo. 型号	Material 材质	Material Thickness 料厚(mm)	WireRang (AWG) 电线范围(线号)	Tab Thickness 公片厚度(mm)	Dimension 尺寸(mm)			Packing 包装
					W	E	L	
FU25008	01 銅 Brass	0.35	16-18 (1.31-0.83)	0.8	7.5	8.0	17.0	2.5K/R
	02 銅鍍錫 TinnedBrass							
	03 鐵鍍鎳 NickelSteel							
	04 銅鍍鎳 NickelBrass							
FS25008	01 銅 Brass	0.35	18-22 (0.83-0.33)	0.8	7.5	7.0	14.4	2.5K/R
	02 銅鍍錫 TinnedBrass							
	03 鐵鍍鎳 NickelSteel							
	04 銅鍍鎳 NickelBrass							
FL25008	01 銅 Brass	0.35	14-16 (2.0-1.3)	0.8	7.5	8.0	17.0	2.5K/R
	02 銅鍍錫 TinnedBrass							
	03 鐵鍍鎳 NickelSteel							
	04 銅鍍鎳 NickelBrass							

6.3旗形端子单边包线 .250" Flag Series Terminals

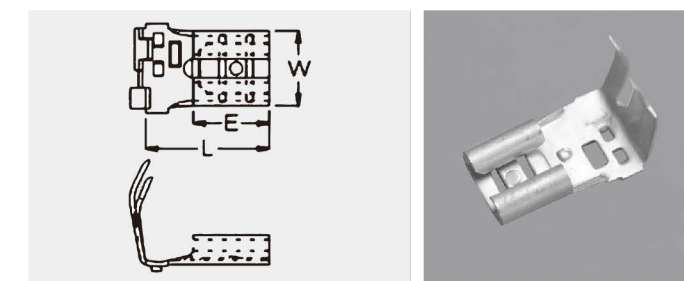

PartNo.型号	Material材质	MaterialThickness 料厚(mm)	WireRang(AWG) 电线范围(线号)	TabThickness 公片厚度(mm)	Dimension尺寸(mm)			Packing 包装
					W	E	L	
FUDT25008	01 銅 Brass	0.35	16-18 (1.31-0.83)	0.8	8.2	7.6	16.4	1.5K/R
	02 銅鍍錫 TinnedBrass	0.40						

6.3旗形带锁端子

250" Flag Series Terminals

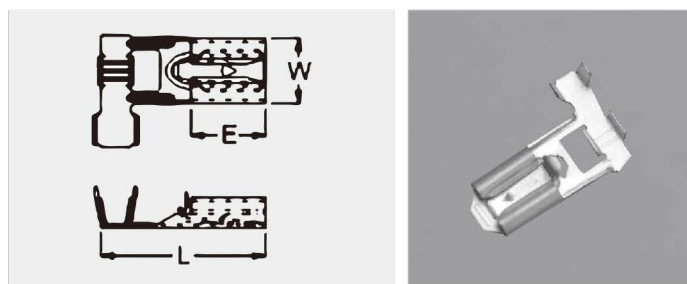

PartNo.型号	Material材质		MaterialThickness料厚(mm)	WireRang(AWG)电线范围(线号)	TabThickness公片厚度(mm)	Dimension尺寸(mm)				Packing包装
						W	E	D	L	
FKT25008UL	01	銅 Brass	0.35	18-22 (0.83-0.31)	0.8	7.6	7.9		20.6	2.5K/R
	02	銅鍍錫 TinnedBrass	0.40							
FKL25008UL	01	銅 Brass	0.35	14-16 (2.5-1.31)	0.8	7.6	7.9		20.6	2.5K/R
	02	銅鍍錫 TinnedBrass	0.40							

6.3旗形带锁端子单边包线

250" Flag Series Terminals

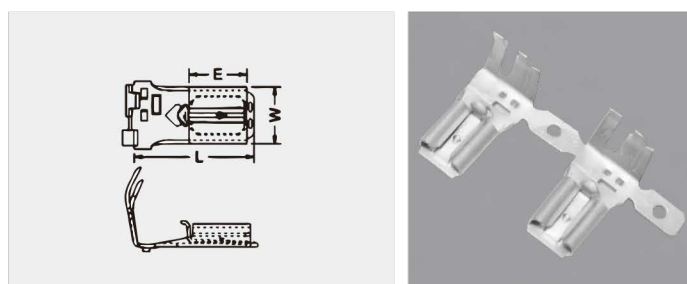

PartNo.型号	Material材质		MaterialThickness料厚(mm)	WireRang(AWG)电线范围(线号)	TabThickness公片厚度(mm)	Dimension尺寸(mm)				Packing包装
						W	E	D	L	
FUKT25008	01	銅 Brass	0.35	18-22 (0.83-0.31)	0.8	7.5	7.6		15.8	1.5K/R
	02	銅鍍錫 TinnedBrass	0.40							

6.3公母一体端子

250" Series Terminals

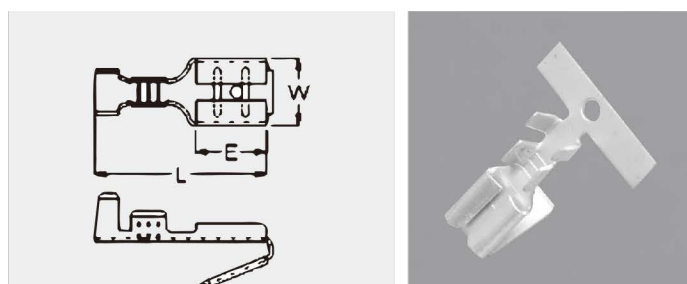

PartNo.型号	Material材质		MaterialThickness料厚(mm)	WireRang(AWG)电线范围(线号)	TabThickness公片厚度(mm)	Dimension尺寸(mm)			Packing包装
						W	E	L	
PG25008	01	銅 Brass	0.35	18-22 (0.83-0.31)	0.8	7.5	8.2	20.4	1.5K/R
	02	銅鍍錫 TinnedBrass	0.40						

6.3插片端子

250" TAB Terminals

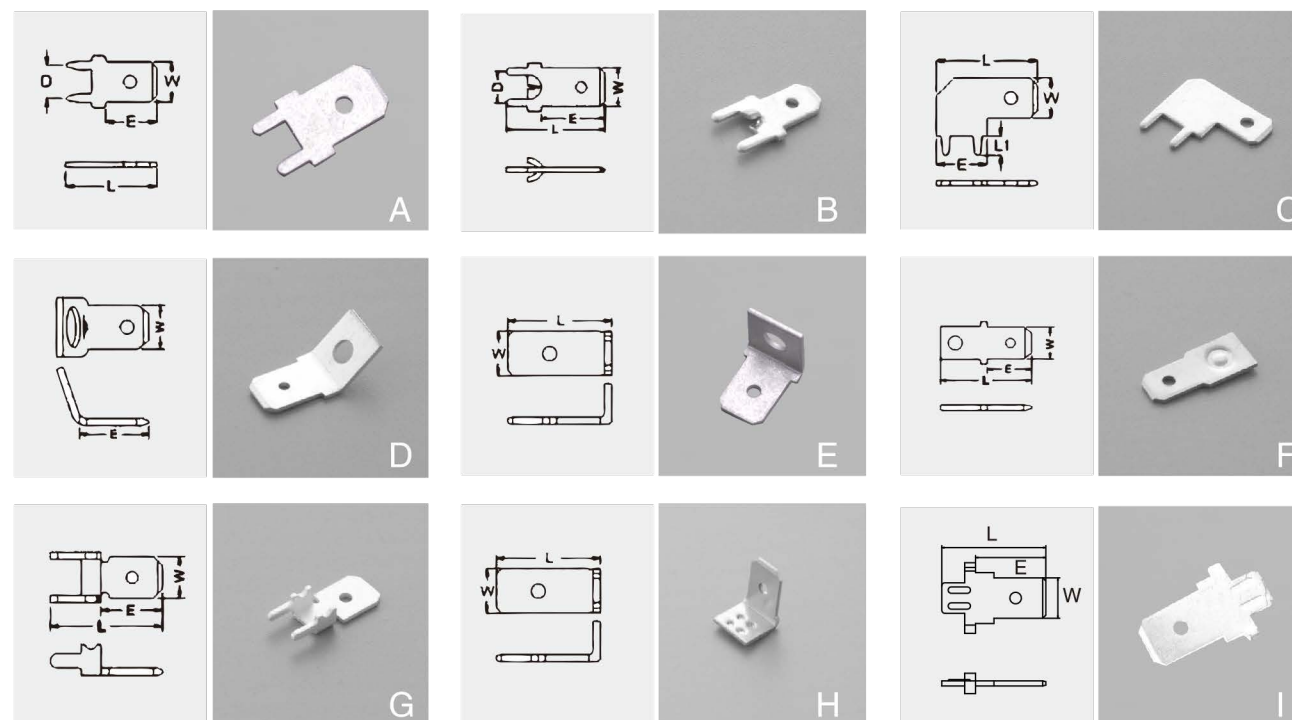

PartNo.型号	Material材质		MaterialThickness料厚(mm)	图号	TabThickness公片厚度(mm)	Dimension尺寸(mm)				Packing包装
						W	E	D	L	
CP2500108	01	銅 Brass	0.80	A	0.8	6.35	8.0	5.0	14.2	5K/B
	02	銅鍍錫 TinnedBrass								
CP2500208	01	銅 Brass	0.80 UL	B	0.8	6.35	8.0	5.0	14.2	5K/B
	02	銅鍍錫 TinnedBrass								
CP2500308	01	銅 Brass	0.80	C	0.8	6.35	8.3	5.0	16.2	5K/B
	02	銅鍍錫 TinnedBrass								
CP2500408	01	銅 Brass	0.80	D	0.8	6.35	7.6			5K/B
	02	銅鍍錫 TinnedBrass								
CP2500508	01	銅 Brass	0.80	E	0.8	6.35	7.6	10		5K/B
	02	銅鍍錫 TinnedBrass								
CP2500608	01	銅 Brass	0.80	F	0.8	6.35	8.2	17.8		5K/B
	02	銅鍍錫 TinnedBrass								
CP2500708	01	銅 Brass	0.80	G	0.8	6.35	8.3	15.7		5K/B
	02	銅鍍錫 TinnedBrass								
CP2500808	01	銅 Brass	0.80	H	0.8	6.35	8.0			5K/B
	02	銅鍍錫 TinnedBrass								
CP2500908	01	銅 Brass	0.80	I	0.8	6.35	11.3	16.4		5K/B
	02	銅鍍錫 TinnedBrass								

6.3插片端子

250" TAB Terminals

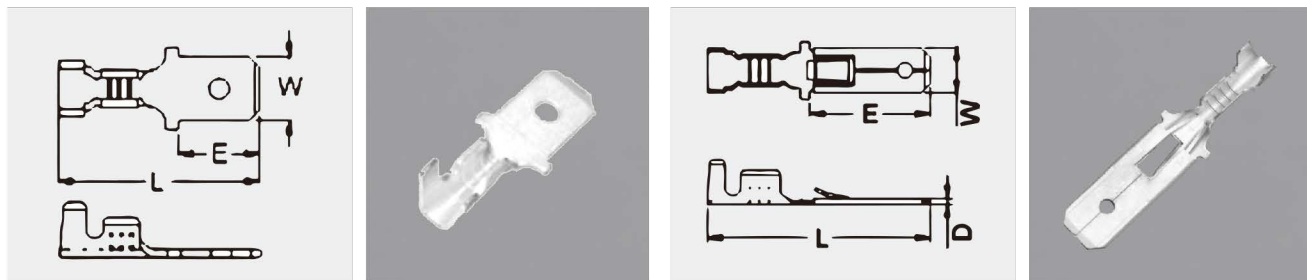

PartNo.型号	Material材质		MaterialThickness料厚(mm)	图号	TabThickness公片厚度(mm)	Dimension尺寸(mm)				Packing包装
						W	E	D	L	
TT250 080UL	01	銅 Brass	0.80	A	0.8	6.35	8.2		19.8	5K/R
	02	銅鍍錫 TinnedBrass								
Tk250 080UL	01	銅 Brass	0.40	B	0.8	6.35	14		25.5	4K/R
	02	銅鍍錫 TinnedBrass								

6.3直型软护套

250" Sleeves

料号 Part No.	Material 材质	颜色 Color	Dimension尺寸(mm)				Packing 包装
			W	E	L	D	
DR250-20	液态PVC	透明白	8.0	13.0	21.0	2.0	2000/包
DR250-20B		透明蓝					
DR250-25	液态PVC	透明白	8.0	13.0	21.0	2.5	2000/包
DR250-25B		透明蓝					
DR250-30	液态PVC	透明白	8.0	13.0	21.0	3.0	2000/包
DR250-30B		透明蓝					
DR250-32	液态PVC	透明白	8.0	13.0	26.0	3.2	2000/包
DR250-32B		透明蓝					
DR250-35	液态PVC	透明白	8.0	13.0	21.0	3.5	2000/包
DR250-35B		透明蓝					
DR250-40	液态PVC	透明白	8.0	13.0	21.0	4.0	2000/包
DR250-40B		透明蓝					
DR250-45	液态PVC	透明白	8.0	13.0	21.0	4.5	2000/包
DR250-45B		透明蓝					
DR250-50	液态PVC	透明白	8.0	13.0	21.0	5.0	2000/包
DR250-50B		透明蓝					
DR250-60	液态PVC	透明白	8.0	13.0	21.0	6.0	2000/包
DR250-60B		透明蓝					

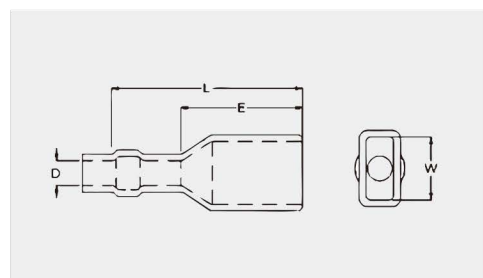

6.3直型倒穿软护套

250" Sleeves

料号 Part No.	Material 材质	颜色 Color	Dimension尺寸(mm)				Packing 包装
			W	E	L	H	
DR-250ES	液态PVC	透明白	7.0	8.5	26.0	3.3	2000/包
DR-250ESB		透明蓝					

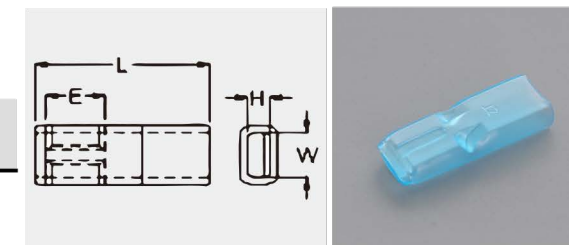

6.3旗型护套

250" flag Sleeves

料号 Part No.	Material 材质	颜色 Color	Dimension尺寸(mm)				Packing 包装
			W	E	L	D	
DF250-40	液态PVC	透明白	8.0	16.0	16.5	4.0	2000/包
DF250-40B		透明蓝					

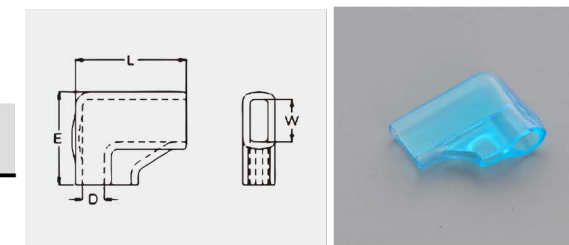

6.3旗型硅胶护套

250" Sleeves

料号 Part No.	Material 材质	颜色 Color	Dimension尺寸(mm)				Packing 包装
			W	E	L	D	
DF250-V0R	阻燃硅胶	白色	12.0	19	19.0	3.5	1000/包
DF250-V0B		红色					

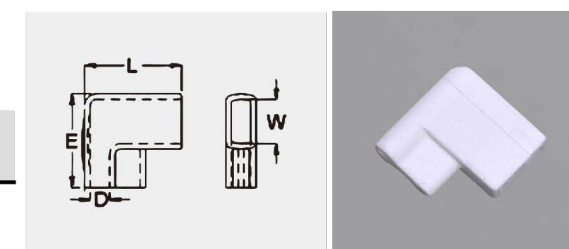

6.3直型硅胶护套

250" Sleeves

料号 Part No.	Material 材质	颜色 Color	Dimension尺寸(mm)				Packing 包装
			W	E	L	D	
DR250-V0R	阻燃硅胶	白色	10.3	15.0	25	3.5	2000/包
DR250-V0B		红色					

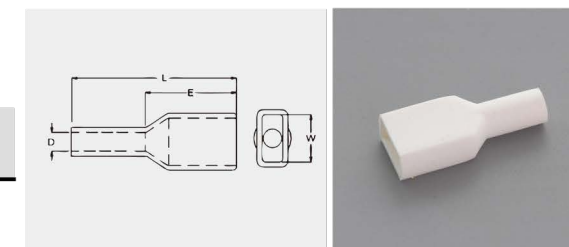

6.3直型硬护套

250" Sleeves

料号 Part No. 型号	Material 材质	颜色 Color	Dimension 尺寸(mm)			Packing 包装
			W	L	H	
DFN250	尼龙PA66	透明本色	9.0	25.4	5.0	2000/包
DFN250-V0		防火V0本色				

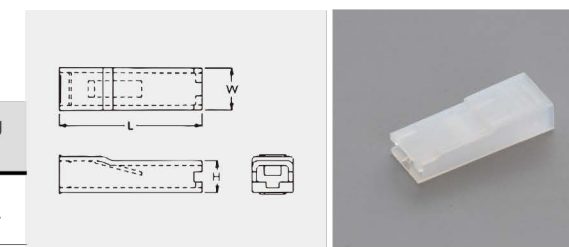

4.8旗型硬护套

187" flag Sleeves

料号 Part No. 型号	Material 材质	颜色 Color	Dimension 尺寸(mm)			Packing 包装
			W	L	H	
DFN250-3	尼龙PA66	透明本色	6.2	16.2	18.3	2000/包
DFN250-3V0		防火V0本色				

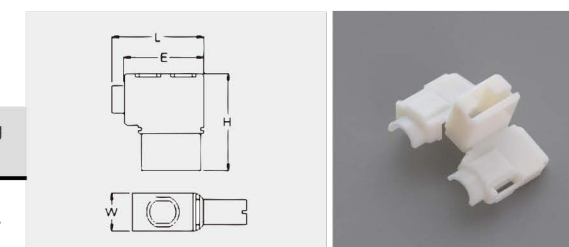

圆型连续端子 Ring Terminals

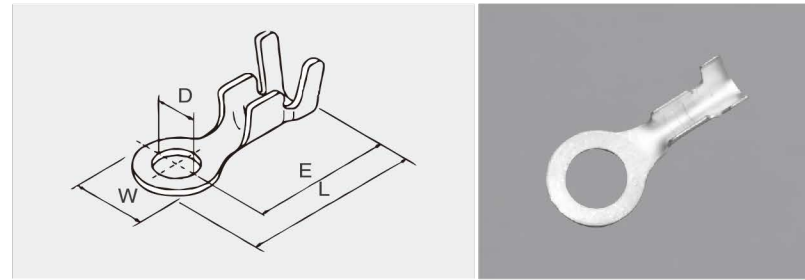

PartNo.型号	Material材质		MaterialThickness料厚(mm)	WireRang(AWG)电线范围(线号)	Dimension尺寸(mm)				Packing包装
					L	E	D	W	
RS 34015 横模	01	銅 Brass	0.25	22-24	6	4.3	1.5	3.4	20K/R
	02	銅鍍錫 Tinned Brass	0.30	(0.33-0.2)					
RT 38021	01	銅 Brass	0.25	22-24	8	6.3	2.1	3.8	30K/R
	02	銅鍍錫 Tinned Brass	0.30	(0.33-0.2)					
RT 46025	01	銅 Brass	0.25	22-24 (0.33-0.27)	9.1	6.8	2.5	4.6	30K/R
	02	銅鍍錫 Tinned Brass	0.25						
	03	鐵鍍鎳 Nickel Steel	0.3						
	04	銅鍍鎳 Nickel Brass	0.3						
RT 50025	01	銅 Brass	0.3	18-22 (0.83-0.33)	10.5	8.0	2.5	5.0	20K/R
	02	銅鍍錫 Tinned Brass	0.3						
	03	鐵鍍鎳 Nickel Steel	0.4						
	04	銅鍍鎳 Nickel Brass	0.4						
RT 50027	01	銅 Brass	0.3	18-22 (0.83-0.33)	10.5	8.0	2.7	5.0	20K/R
	02	銅鍍錫 Tinned Brass	0.3						
	03	鐵鍍鎳 Nickel Steel	0.4						
	04	銅鍍鎳 Nickel Brass	0.4						
RT50032	01	銅 Brass	0.3	18-22 (0.83-0.33)	10.5	8.0	3.2	5.0	20K/R
	02	銅鍍錫 Tinned Brass	0.3						
	03	鐵鍍鎳 Nickel Steel	0.4						
	04	銅鍍鎳 Nickel Brass	0.5						
RT 60025	01	銅 Brass	0.3	20-16 (0.5-1.5)	11.5	8.5	2.5	6.0	15K/R
	02	銅鍍錫 Tinned Brass	0.3						
	03	鐵鍍鎳 Nickel Steel	0.4						
	04	銅鍍鎳 Nickel Brass	0.4						
RT 60032	01	銅 Brass	0.3	20-16 (0.5-1.5)	11.5	8.5	3.2	6.0	15K/R
	02	銅鍍錫 Tinned Brass	0.3						
	03	鐵鍍鎳 Nickel Steel	0.4						
	04	銅鍍鎳 Nickel Brass	0.4						
RT 60037	01	銅 Brass	0.3	20-16 (0.5-1.5)	11.5	8.5	3.7	6.0	15K/R
	02	銅鍍錫 Tinned Brass	0.3						
	03	鐵鍍鎳 Nickel Steel	0.4						
	04	銅鍍鎳 Nickel Brass	0.4						
RT 65025	01	銅 Brass	0.3	20-16 (0.5-1.5)	11.5	8.5	2.5	6.5	15K/R
	02	銅鍍錫 Tinned Brass	0.3						
	03	鐵鍍鎳 Nickel Steel	0.4						
	04	銅鍍鎳 Nickel Brass	0.5						
RT 65032	01	銅 Brass	0.3	20-16 (0.5-1.5)	11.5	8.5	3.2	6.5	15K/R
	02	銅鍍錫 Tinned Brass	0.3						
	03	鐵鍍鎳 Nickel Steel	0.4						
	04	銅鍍鎳 Nickel Brass	0.5						
RT 65037	01	銅 Brass	0.3	20-16 (0.5-1.5)	11.5	8.5	3.7	6.5	15K/R
	02	銅鍍錫 Tinned Brass	0.3						
	03	鐵鍍鎳 Nickel Steel	0.4						
	04	銅鍍鎳 Nickel Brass	0.5						
RT 65043	01	銅 Brass	0.3	20-16 (0.5-1.5)	11.5	8.5	4.3	6.5	15K/R
	02	銅鍍錫 Tinned Brass	0.3						
	03	鐵鍍鎳 Nickel Steel	0.4						
	04	銅鍍鎳 Nickel Brass	0.5						
RT65043-L	01	銅 Brass	0.50	20-16 (0.5-1.5)	16.2	13	4.3	6.5	7K/R
	02	銅鍍錫 Tinned Brass	0.50						
	03	鐵鍍鎳 Nickel Steel	0.60						
	04	銅鍍鎳 Nickel Brass	0.70						

圆型连续端子 Ring Terminals

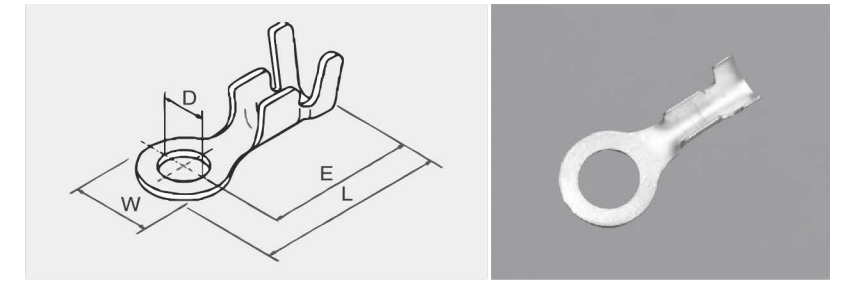

PartNo.型号	Material材质		MaterialThickness料厚(mm)	WireRang(AWG)电线范围(线号)	Dimension尺寸(mm)				Packing包装
					L	E	D	W	
RT 70025	01	銅 Brass	0.3	14-20 (2.0-0.52)	16.5	13.0	2.5	7.0	7K/R
	02	銅鍍錫 Tinned Brass	0.3						
	03	鐵鍍鎳 Nickel Steel	0.4						
	04	銅鍍鎳 Nickel Brass	0.5						
RT 70032	01	銅 Brass	0.3	14-20 (2.0-0.52)	16.5	13.0	3.2	7.0	7K/R
	02	銅鍍錫 Tinned Brass	0.3						
	03	鐵鍍鎳 Nickel Steel	0.4						
	04	銅鍍鎳 Nickel Brass	0.5						
RT 70037	01	銅 Brass	0.3	14-20 (2.0-0.52)	16.5	13.0	3.7	7.0	7K/R
	02	銅鍍錫 Tinned Brass	0.3						
	03	鐵鍍鎳 Nickel Steel	0.4						
	04	銅鍍鎳 Nickel Brass	0.5						
RT 70043	01	銅 Brass	0.3	14-20 (2.0-0.52)	16.5	13.0	4.3	7.0	7K/R
	02	銅鍍錫 Tinned Brass	0.3						
	03	鐵鍍鎳 Nickel Steel	0.4						
	04	銅鍍鎳 Nickel Brass	0.5						
RT 70051	01	銅 Brass	0.3	14-20 (2.0-0.52)	16.5	13.0	5.1	7.0	7K/R
	02	銅鍍錫 Tinned Brass	0.3						
	03	鐵鍍鎳 Nickel Steel	0.4						
	04	銅鍍鎳 Nickel Brass	0.5						
RL 75043	01	銅 Brass	0.40	14-16 (2.0-0.131)	16.8	13.0	4.3	7.5	7K/R
	02	銅鍍錫 Tinned Brass	0.50						
	03	鐵鍍鎳 Nickel Steel	0.70						
	04	銅鍍鎳 Nickel Brass	0.70						
RT 75032	01	銅 Brass	0.3	14-20 (2.0-0.52)	16.8	13.0	3.2	7.5	7K/R
	02	銅鍍錫 Tinned Brass	0.3						
	03	鐵鍍鎳 Nickel Steel	0.4						
	04	銅鍍鎳 Nickel Brass	0.5						
RT 75037	01	銅 Brass	0.3	14-20 (2.0-0.52)	16.8	13.0	3.7	7.5	7K/R
	02	銅鍍錫 Tinned Brass	0.3						
	03	鐵鍍鎳 Nickel Steel	0.4						
	04	銅鍍鎳 Nickel Brass	0.5						
RT 75043	01	銅 Brass	0.3	14-20 (2.0-0.52)	16.8	13.0	4.3	7.5	7K/R
	02	銅鍍錫 Tinned Brass	0.3						
	03	鐵鍍鎳 Nickel Steel	0.4						
	04	銅鍍鎳 Nickel Brass	0.5						
RT 75051	01	銅 Brass	0.3	14-20 (2.0-0.52)	16.8	13.0	5.1	7.5	7K/R
	02	銅鍍錫 Tinned Brass	0.3						
	03	鐵鍍鎳 Nickel Steel	0.4						
	04	銅鍍鎳 Nickel Brass	0.5						
RT 85043	01	銅 Brass	0.3	16-20 (2.0-0.52)	18.8	14.5	4.3	8.5	7K/R
	02	銅鍍錫 Tinned Brass	0.3						
	03	鐵鍍鎳 Nickel Steel	0.4						
	04	銅鍍鎳 Nickel Brass	0.5						
RT 85051	01	銅 Brass	0.3	16-20 (2.0-0.52)	18.8	14.5	5.1	8.5	7K/R
	02	銅鍍錫 Tinned Brass	0.3						
	03	鐵鍍鎳 Nickel Steel	0.4						
	04	銅鍍鎳 Nickel Brass	0.5						
RL 85043	01	銅 Brass	0.50	12-16 (2.5-1.31)	21.0	16.3	4.3	8.5	3K/R
	02	銅鍍錫 Tinned Brass	0.80						
	03	鐵鍍鎳 Nickel Steel	0.80						
	04	銅鍍鎳 Nickel Brass	0.80						
RL 85053	01	銅 Brass	0.50	12-16 (2.5-1.31)	21.0	16.3	5.3	8.5	3K/R
	02	銅鍍錫 Tinned Brass	0.50						
	03	鐵鍍鎳 Nickel Steel	0.80						
	04	銅鍍鎳 Nickel Brass	0.80						

圆型连续端子 Ring Terminals

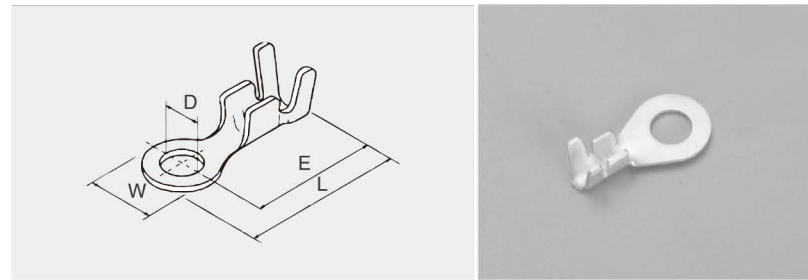

PartNo.型号	Material材质		MaterialThickness料厚(mm)	WireRang(AWG)电线范围(线号)	Dimension尺寸(mm)				Packing包装	
					L	E	D	W		
RL 10053	01	銅	Brass	0.50	12-16 (4.0-1.5)	21.4	17.5	5.3	10	3K/R
	02	銅鍍錫	Tinned Brass	0.80						
RL 10064	01	銅	Brass	0.50	12-14 (4.0-2.5)	21.4	17.5	6.4	10	3K/R
	02	銅鍍錫	Tinned Brass	0.80						
RL1005502-80C	01	銅	Brass	0.50	12-14 (4.0-2.5)	21.4	16.8	5.5	10	3K/R
	02	銅鍍錫	Tinned Brass							
	03	鐵鍍鎳	Nickel Steel							
	04	銅鍍鎳	Nickel Brass							
RT 12053	01	銅	Brass	0.30	16-20 (1.5-0.5)	22.0	16.0	5.3	12.0	3K/R
	02	銅鍍錫	Tinned Brass							
	03	鐵鍍鎳	Nickel Steel							
	04	銅鍍鎳	Nickel Brass							
RT 12064	01	銅	Brass	0.30	16-20 (1.5-0.5)	22.0	16.0	6.4	12.0	3K/R
	02	銅鍍錫	Tinned Brass							
	03	鐵鍍鎳	Nickel Steel							
	04	銅鍍鎳	Nickel Brass							
RT 12084	01	銅	Brass	0.30	16-20 (1.5-0.5)	22.0	16.0	8.4	12.0	3K/R
	02	銅鍍錫	Tinned Brass							
	03	鐵鍍鎳	Nickel Steel							
	04	銅鍍鎳	Nickel Brass							
RL 12055	01	銅	Brass	0.60	12-16 (4.0-1.5)	24.5	18.5	5.5	12.0	2K/R
	02	銅鍍錫	Tinned Brass							
	03	鐵鍍鎳	Nickel Steel							
	04	銅鍍鎳	Nickel Brass							
RL 12064	01	銅	Brass	0.60	12-16 (4.0-1.5)	22.5	16.5	6.4	12.0	2K/R
	02	銅鍍錫	Tinned Brass							
	03	鐵鍍鎳	Nickel Steel							
	04	銅鍍鎳	Nickel Brass							
RL 15084	01	銅	Brass	1.00	12-16 (4.0-1.5)	28.5	21.0	8.4	15.0	1.5K/R
	02	銅鍍錫	Tinned Brass							
	03	鐵鍍鎳	Nickel Steel							
	04	銅鍍鎳	Nickel Brass							
RL 15010	01	銅	Brass	1.00	12-16 (4.0-1.5)	28.5	21.0	10.5	15.0	1.5K/R
	02	銅鍍錫	Tinned Brass							
	03	鐵鍍鎳	Nickel Steel							
	04	銅鍍鎳	Nickel Brass							
RT160110	01	銅	Brass	0.35	16-20 (1.5-0.5)	28.0	20.0	11.0	16.0	2.5K/R
	02	銅鍍錫	Tinned Brass							
	03	鐵鍍鎳	Nickel Steel							
	04	銅鍍鎳	Nickel Brass							
RT 160130	01	銅	Brass	0.35	16-20 (1.5-0.5)	28.0	20.0	13.0	16.0	2.5K/R
	02	銅鍍錫	Tinned Brass							
	03	鐵鍍鎳	Nickel Steel							
	04	銅鍍鎳	Nickel Brass							

圆型单脚连续端子 Ring Terminals

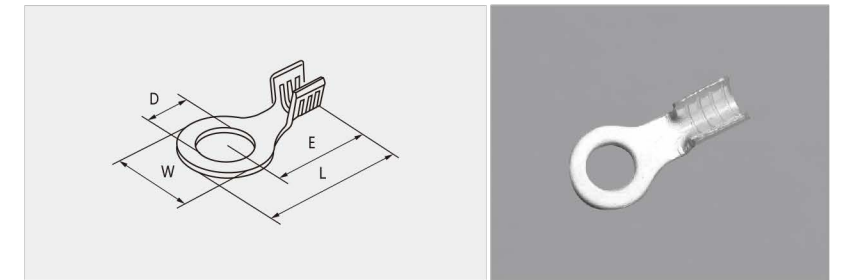

PartNo.型号	Material材质		MaterialThickness料厚(mm)	WireRang(AWG)电线范围(线号)	Dimension尺寸(mm)				Packing包装	
					L	E	D	W		
RJ 46025	01	銅	Brass	0.27	22-24 (0.24-0.52)	9.3	7.0	2.5	4.6	30K/R
	02	銅鍍錫	Tinned Brass							
	03	鐵鍍鎳	Nickel Steel							
	04	銅鍍鎳	Nickel Brass							
RJ 70043	01	銅	Brass	0.3	18-20 (0.83-0.52)	16.5	13	4.3	7.0	7K/R
	02	銅鍍錫	Tinned Brass							
	03	鐵鍍鎳	Nickel Steel							
	04	銅鍍鎳	Nickel Brass							

圆型太阳止滑连续端子 Ring Terminals

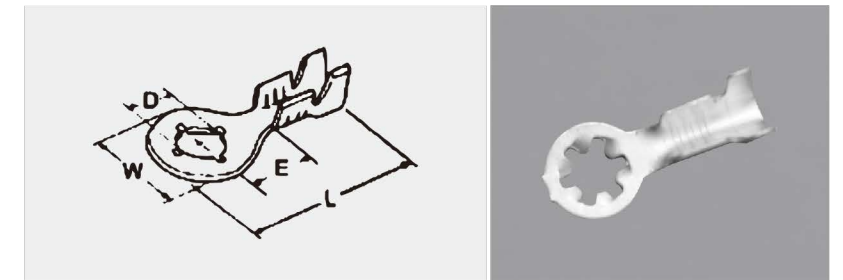

PartNo.型号	Material材质		MaterialThickness料厚(mm)	WireRang(AWG)电线范围(线号)	Dimension尺寸(mm)				Packing包装	
					L	E	D	W		
RH 65032	01	銅	Brass	0.30	18-22 (0.83-0.33)	11.5	8.25	3.2	6.0	10K/R
	02	銅鍍錫	Tinned Brass							
	03	鐵鍍鎳	Nickel Steel							
	04	銅鍍鎳	Nickel Brass							
RH 75032	01	銅	Brass	0.40	18-22 (0.83-0.33)	16.1	12.6	3.2	7.0	10K/R
	02	銅鍍錫	Tinned Brass							
	03	鐵鍍鎳	Nickel Steel							
	04	銅鍍鎳	Nickel Brass							
RH85043	01	銅	Brass	0.30	18-22 (0.83-0.33)	18.8	14.5	4.3	8.5	7K/R
	02	銅鍍錫	Tinned Brass							
	03	鐵鍍鎳	Nickel Steel							
	04	銅鍍鎳	Nickel Brass							
RH 85053	01	銅	Brass	0.30	16-20 (1.31-0.52)	18.8	14.5	5.3	8.5	7K/R
	02	銅鍍錫	Tinned Brass							
	03	鐵鍍鎳	Nickel Steel							
	04	銅鍍鎳	Nickel Brass							
RH 95053	01	銅	Brass	0.50	14-16 (2.0-1.31)	20.6	16	5.3	9.5	4K/R
	02	銅鍍錫	Tinned Brass							
	03	鐵鍍鎳	Nickel Steel							
	04	銅鍍鎳	Nickel Brass							

叉形连续端子 Spade Terminals

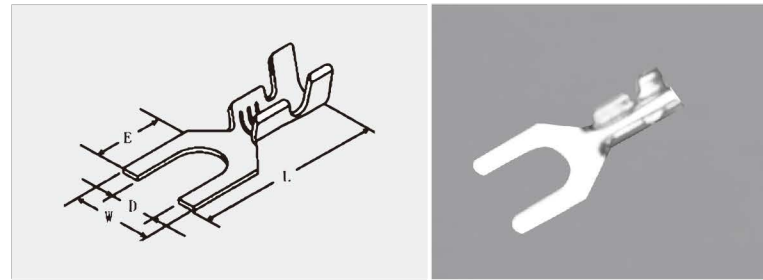

PartNo.型号	Material材质			MaterialThickness料厚(mm)	WireRang(AWG)电线范围(线号)	Dimension尺寸(mm)				Packing包装
						L	E	D	W	
YT 60032横模	01	銅	Brass	0.3/0.35	24-20 (0.2-0.52)	14.5	4	3.2	6.0	10K/R
	02	銅鍍錫	Tinned Brass							
	04	銅鍍鎳	Nickel Brass							
YT 75042横模	01	銅	Brass	0.3/0.35	22-18 (0.33-0.83)	16.9	6.2	4.2	7.5	10K/R
	02	銅鍍錫	Tinned Brass							
	04	銅鍍鎳	Nickel Brass							
YT 65032	01	銅	Brass	0.4	16-20 (1.31-0.52)	16.0	6.2	3.2	6.5	10K/R
	02	銅鍍錫	Tinned Brass	0.50						
	04	銅鍍鎳	Nickel Brass	0.7						
YT 570	01	銅	Brass	0.4	16-20 (1.31-0.52)	16.0	6.2	3.2	6.5	10K/R
	02	銅鍍錫	Tinned Brass	0.50						
	04	銅鍍鎳	Nickel Brass	0.7						
YT 65043	01	銅	Brass	0.4	16-20 (1.31-0.52)	17.0	6.2	4.3	6.5	10K/R
	02	銅鍍錫	Tinned Brass	0.50						
	04	銅鍍鎳	Nickel Brass	0.7						
YT 72032	01	銅	Brass	0.3	16-20 (1.31-0.52)	18.0	7.2	3.2	7.2	7K/R
	02	銅鍍錫	Tinned Brass	0.35						
	04	銅鍍鎳	Nickel Brass	0.4						
YT 72037	01	銅	Brass	0.30	16-20 (1.31-0.52)	18.0	7.2	3.7	7.2	7K/R
	02	銅鍍錫	Tinned Brass	0.35						
	04	銅鍍鎳	Nickel Brass	0.4						
YT 72043	01	銅	Brass	0.30	16-20 (1.31-0.52)	18.0	7.2	4.3	7.2	7K/R
	02	銅鍍錫	Tinned Brass	0.35						
	04	銅鍍鎳	Nickel Brass	0.4						
YT 71043	01	銅	Brass	0.30	16-20 (1.31-0.52)	18.2	7.2	4.3	7.4	7K/R
	02	銅鍍錫	Tinned Brass	0.35						
	04	銅鍍鎳	Nickel Brass	0.4						
YL 70043	01	銅	Brass	0.70	18-14 (0.83-2.5)	18.0	7.2	4.3	7.0	5K/R
	02	銅鍍錫	Tinned Brass							
	04	銅鍍鎳	Nickel Brass							
YT 75042横模	01	銅	Brass	0.80	16-20 (1.31-0.52)	17.5	7.2	4.2	7.5	4K/R
	02	銅鍍錫	Tinned Brass							
	04	銅鍍鎳	Nickel Brass							
YL 85043	01	銅	Brass	0.80	12-16 (4.0-1.31)	21.5	7.7	4.3	8.5	3K/R
	02	銅鍍錫	Tinned Brass							
	04	銅鍍鎳	Nickel Brass							
YL 85053	01	銅	Brass	0.80	12-16 (4.0-1.31)	21.5	7.7	5.3	8.5	3K/R
	02	銅鍍錫	Tinned Brass							
	04	銅鍍鎳	Nickel Brass							
YJ 95051	01	銅	Brass	0.70	14-16 (1.25-1.31)	14.0	9.0	5.1	9.0	5K/R
	02	銅鍍錫	Tinned Brass							
	04	銅鍍鎳	Nickel Brass							
YL 6043	01	銅	Brass	0.70	18-14 (0.83-2.5)	18.1	6.9	4.2	6.0	
	02	銅鍍錫	Tinned Brass							
	04	銅鍍鎳	Nickel Brass							

碰焊端子 Welding Terminals

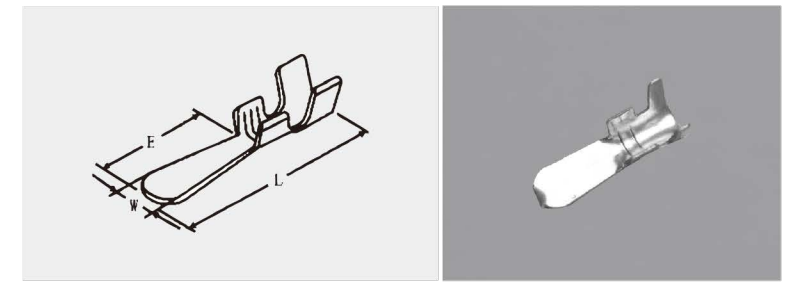

PartNo.型号	Material材质			MaterialThickness料厚(mm)	WireRang(AWG)电线范围(线号)	Dimension尺寸(mm)				Packing包装
						L	E	W	D	
TT 35000	01	銅	Brass	0.3	16-22 (1.31-0.33)	12.0	7.0	3.5		10K/R
	02	銅鍍錫	Tinned Brass							
	03	鐵鍍鎳	Nickel Steel							
	04	銅鍍鎳	Nickel Brass							
	05	不銹鐵	Stainless Steel							
TT 40000	01	銅	Brass	0.3	14-20 (2.0-0.52)	15	8	4.0		7K/R
	02	銅鍍錫	Tinned Brass							
	03	鐵鍍鎳	Nickel Steel							
	04	銅鍍鎳	Nickel Brass							
	05	不銹鐵	Stainless Steel							

圓形碰焊端子 Welding Terminals

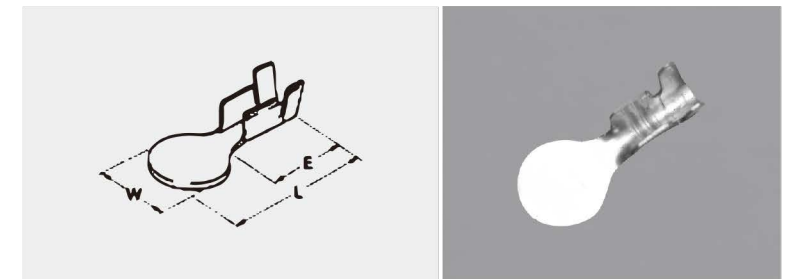

PartNo.型号	Material材质			MaterialThickness料厚(mm)	WireRang(AWG)电线范围(线号)	Dimension尺寸(mm)				Packing包装
						L	E	W	D	
WT 50000	01	銅	Brass	0.3	18-22 (0.83-0.33)	10.5	8.8	5.0		15K/R
	02	銅鍍錫	Tinned Brass							
	03	鐵鍍鎳	Nickel Steel							
	04	銅鍍鎳	Nickel Brass							
	05	不銹鐵	Stainless Steel							
WT 60000	01	銅	Brass	0.3	18-22 (0.83-0.33)	11.5	8.5	6.0		10K/R
	02	銅鍍錫	Tinned Brass							
	03	鐵鍍鎳	Nickel Steel							
	04	銅鍍鎳	Nickel Brass							
	05	不銹鐵	Stainless Steel							
WT 65000	01	銅	Brass	0.3	18-22 (0.83-0.33)	11.5	8.5	6.5		10K/R
	02	銅鍍錫	Tinned Brass							
	03	鐵鍍鎳	Nickel Steel							
	04	銅鍍鎳	Nickel Brass							
	05	不銹鐵	Stainless Steel							
WT 70000	01	銅	Brass	0.4	18-22 (0.83-0.33)	16.8	13.0	7.0		7K/R
	02	銅鍍錫	Tinned Brass							
	03	鐵鍍鎳	Nickel Steel							
	04	銅鍍鎳	Nickel Brass							
	05	不銹鐵	Stainless Steel							
WT 75000	01	銅	Brass	0.3	14-20 (2.0-0.52)	16.8	13.0	7.5		7K/R
	02	銅鍍錫	Tinned Brass							
	03	鐵鍍鎳	Nickel Steel							
	04	銅鍍鎳	Nickel Brass							
	05	不銹鐵	Stainless Steel							
WT 85000	01	銅	Brass	0.3	14-20 (2.0-0.52)	16.8	13.0	8.0		7K/R
	02	銅鍍錫	Tinned Brass							
	03	鐵鍍鎳	Nickel Steel							
	04	銅鍍鎳	Nickel Brass							
	05	不銹鐵	Stainless Steel							

子弹形公端 Bullet Terminals

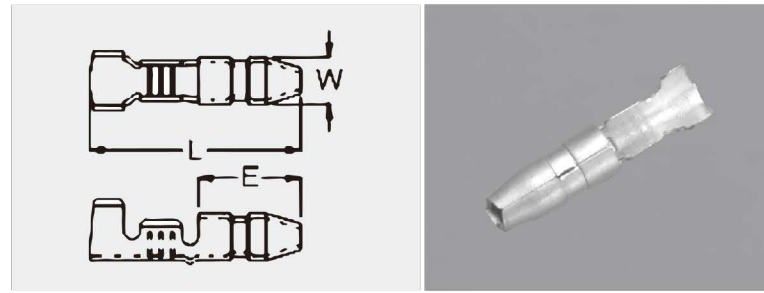

PartNo.型号	Material材质		MaterialThickness 料厚(mm)	WireRang(AWG) 电线范围(线号)	Dimension尺寸(mm)			Packing包装	
					L	E	W		
NP35000	01	銅	Brass	0.35	18-22 (0.83-0.33)	16.3	6.5	3.5	10K/R
	02	銅鍍錫	Tinned Brass						
	04	銅鍍鎳	Nickel Brass						
NP40000	01	銅	Brass	0.35	18-22 (0.83-0.33)	17.3	6.5	3.96	10K/R
	02	銅鍍錫	Tinned Brass						
	04	銅鍍鎳	Nickel Brass						

子弹形母端 Bullet Terminals

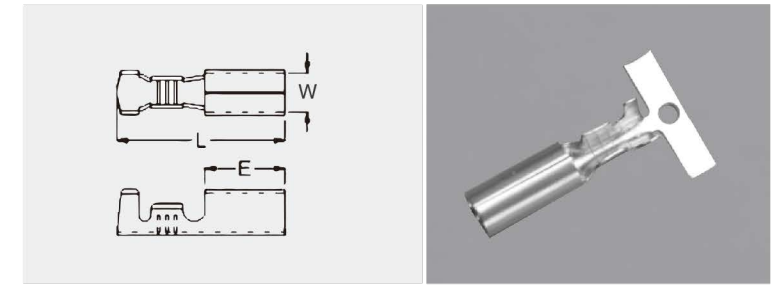

PartNo.型号	Material材质		MaterialThickness 料厚(mm)	WireRang(AWG) 电线范围(线号)	Dimension尺寸(mm)				Packing包装
					L	E	W	D	
NM45000	01	銅	Brass	0.35	14-18 (2.5-1.31)	20.0	10.8	4.5	3K/R
	02	銅鍍錫	Tinned Brass						
	04	銅鍍鎳	Nickel Brass						
金手指公端	01	銅	Brass	0.3	22-16 (0.33-1.5)	19.5	10.8	4.9	3K/R
	02	銅鍍錫	Tinned Brass						
	04	銅鍍鎳	Nickel Brass						

子弹形母端 Bullet Terminals

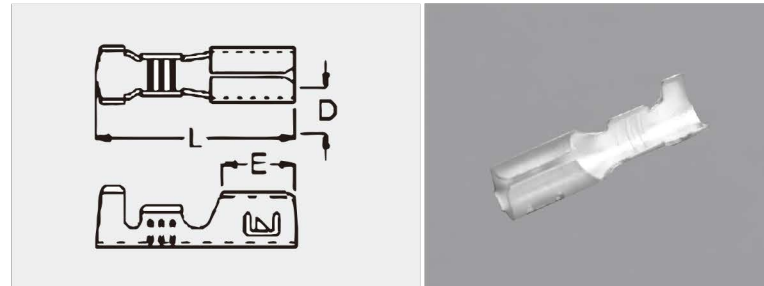

PartNo.型号	Material材质		MaterialThickness 料厚(mm)	WireRang(AWG) 电线范围(线号)	Dimension尺寸(mm)			Packing包装	
					L	E	W		
NM35000	01	銅	Brass	0.35	18-22 (0.83-0.33)	17.3	6.4	3.5	10K/R
	02	銅鍍錫	Tinned Brass						
	04	銅鍍鎳	Nickel Brass						
NM40000	01	銅	Brass	0.35	18-22 (0.83-0.33)	17.3	6.4	3.96	10K/R
	02	銅鍍錫	Tinned Brass						
	04	銅鍍鎳	Nickel Brass						

子弹型端子软护套 Bullet Sleeves

料号 Part No.	Material 材质	颜色 Color	Dimension尺寸 (mm)				Packing 包装
			W	E	L	D	
DJ211-25	液态PVC	白色			14.0	2.5	2000/包
DT211-25B		蓝色					
DJ211-30	液态PVC	白色			14.0	3.0	2000/包
DJ211-30B		蓝色					
DJ211-35	液态PVC	白色			14.0	3.5	2000/包
DJ211-35B		蓝色					
DJ211-40	液态PVC	白色			14.0	4.0	2000/包
DJ211-40B		蓝色					

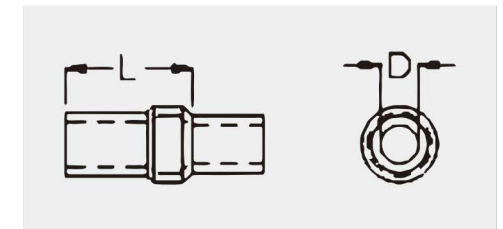

子弹形公端 Bullet Terminals

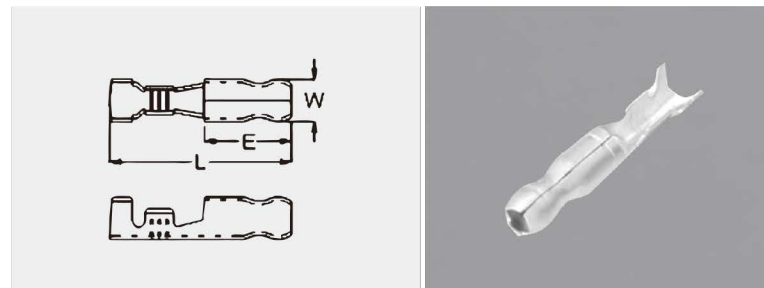

PartNo.型号	Material材质		MaterialThickness 料厚(mm)	WireRang(AWG) 电线范围(线号)	Dimension尺寸(mm)			Packing 包装	
					L	E	W		
NP45000	01	銅	Brass	0.35	18-14 (2.5-1.31)	22.2	11.8	4.5	3K/R
	02	銅鍍錫	Tinned Brass						
	04	銅鍍鎳	Nickel Brass						
金手指公端	01	銅	Brass	0.35	22-16 (0.33-1.5)	21.8	12	4.4	3K/R
	02	銅鍍錫	Tinned Brass						
	04	銅鍍鎳	Nickel Brass						

料号 Part No.	Material 材质	颜色 Color	Dimension尺寸 (mm)				Packing 包装
			W	E	L	D	
DJ221-25	液态PVC	白色		26.0	31.0	2.5	2000/包
DJ221-25B		蓝色					
DJ221-30	液态PVC	白色		9.0	14.0	3.0	2000/包
DJ221-30B		蓝色					
DJ221-35	液态PVC	白色		25.0	30.0	3.5	2000/包
DJ221-35B		蓝色					
DJ221-40	液态PVC	白色		26.0	31.0	4.0	2000/包
DJ221-40B		蓝色					

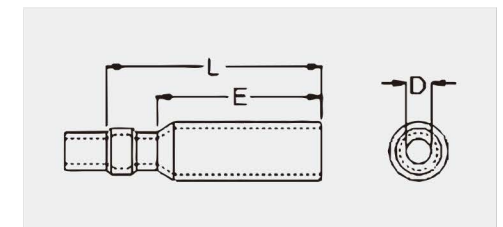

铜管端子 PIN Terminals

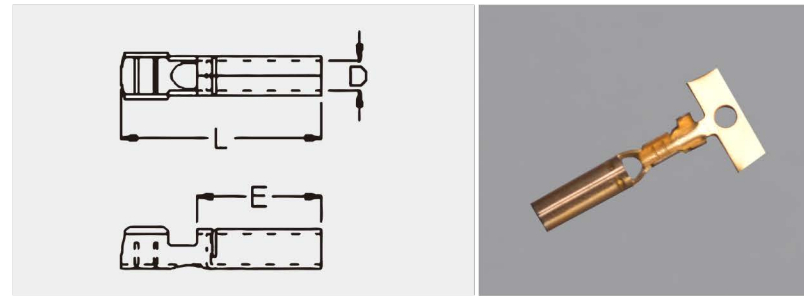

PartNo.型号	Material材质		MaterialThickness料厚(mm)	WireRang(AWG)电线范围(线号)	Dimension尺寸(mm)				Packing包装
					L	E	W	D	
Nt1000	01	銅 Brass	0.25	24-26 (0.2-0.12)	14.6	9.8		1.0	10K/R
	02	銅鍍錫 Tinned Brass							
	04	銅鍍鎳 Nickel Brass							
NT15000	01	銅 Brass	0.30	18-22 (0.83-0.33)	13.2	8.6		1.5	10K/R
	02	銅鍍錫 Tinned Brass							
	04	銅鍍鎳 Nickel Brass							
NT20000	01	銅 Brass	0.30	18-20 (0.83-0.52)	14.5	7.5		2.0	15K/R
	02	銅鍍錫 Tinned Brass							
	04	銅鍍鎳 Nickel Brass							
NT23500	01	銅 Brass	0.35	18-20 (0.83-0.52)	15.8	9.1		2.3	10K/R
	02	銅鍍錫 Tinned Brass							
	04	銅鍍鎳 Nickel Brass							

铜针端子 Brass Needle

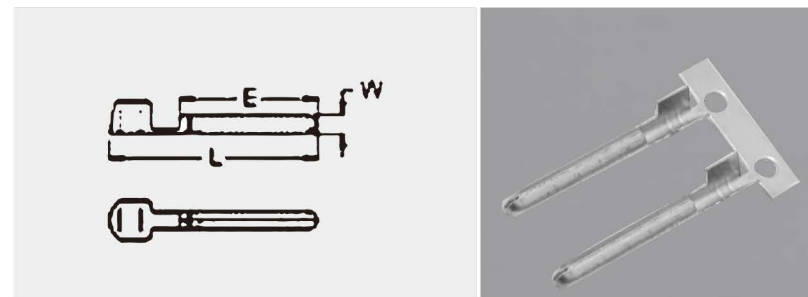

PartNo.型号	Material材质		MaterialThickness料厚(mm)	WireRang(AWG)电线范围(线号)	Dimension尺寸(mm)				Packing包装
					L	E	W	D	
Np1000	01	銅 Brass	0.20	22-26 (0.33-0.12)	15.8	11.5		1.0	10K/R
	02	銅鍍錫 Tinned Brass							
	04	銅鍍鎳 Nickel Brass							
NP15000	01	銅 Brass	0.25	18-22 (0.83-0.33)	18.4	14.2		1.5	10K/R
	02	銅鍍錫 Tinned Brass							
	04	銅鍍鎳 Nickel Brass							
NP23500	01	銅 Brass	0.30	18-20 (0.83-0.52)	20.2	14.2		2.3	10K/R
	02	銅鍍錫 Tinned Brass							
	04	銅鍍鎳 Nickel Brass							
NP23500 加长	01	銅 Brass	0.35	18-20 (0.83-0.52)	20.2	14.2		2.3	10K/R
	02	銅鍍錫 Tinned Brass							
	04	銅鍍鎳 Nickel Brass							

接线包线端子 Button Terminals

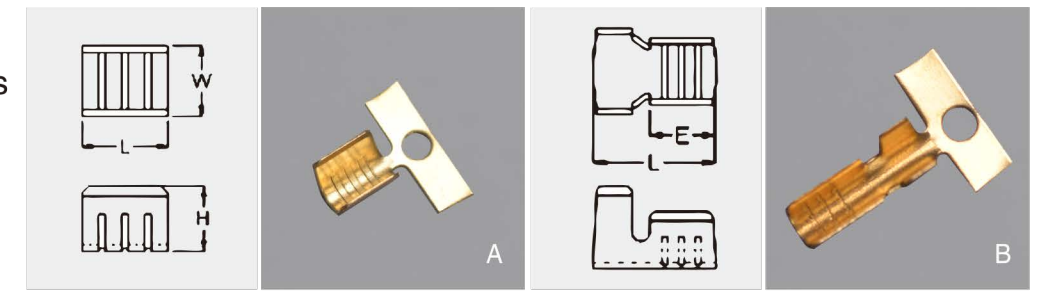

PartNo.型号	Material材质		MaterialThickness料厚(mm)	WireRang(AWG)电线范围(线号)	Dimension尺寸(mm)				Packing包装	图号
					L	E	W	H		
WS25000	01	銅 Brass	0.30	18-20 (0.83-0.52)	4	-	3.2	2.6	20K/R	A
	02	銅鍍錫 Tinned Brass								
	03	鐵鍍鎳 Nickel Steel								
	04	不銹鐵 Stainless Steel								
	05	不銹鐵 Stainless Steel								
WS34000	01	銅 Brass	0.40	16-20 (1.31-0.52)	4	-	4	4.2	10K/R	A
	02	銅鍍錫 Tinned Brass								
	03	鐵鍍鎳 Nickel Steel								
	04	不銹鐵 Stainless Steel								
	05	不銹鐵 Stainless Steel								
WS35000	01	銅 Brass	0.40	16-20 (1.31-0.52)	5.1	-	4	4.2	10K/R	A
	02	銅鍍錫 Tinned Brass								
	03	鐵鍍鎳 Nickel Steel								
	04	不銹鐵 Stainless Steel								
	05	不銹鐵 Stainless Steel								
WS27000	01	銅 Brass	0.30	16-20 (1.31-0.52)	8.5	5.5	-	-	7K/R	B
	02	銅鍍錫 Tinned Brass								
	03	鐵鍍鎳 Nickel Steel								
	04	不銹鐵 Stainless Steel								
	05	不銹鐵 Stainless Steel								
WS27000-S	01	銅 Brass	0.30	20-22 (0.52-0.33)	8.5	5.5	-	-	10K/R	B
	02	銅鍍錫 Tinned Brass								
	03	鐵鍍鎳 Nickel Steel								
	04	不銹鐵 Stainless Steel								
	05	不銹鐵 Stainless Steel								
WL27000-S	01	銅 Brass	0.40	14-16 (2.5-1.31)	9.4	6	-	-	4K/R	B
	02	銅鍍錫 Tinned Brass								
	03	鐵鍍鎳 Nickel Steel								
	04	不銹鐵 Stainless Steel								
	05	不銹鐵 Stainless Steel								
WL27000-L	01	銅 Brass	0.40	12-14 (4.0-2.5)	9.4	6	-	-	4K/R	B
	02	銅鍍錫 Tinned Brass								
	03	鐵鍍鎳 Nickel Steel								
	04	不銹鐵 Stainless Steel								
	05	不銹鐵 Stainless Steel								
WS17000	01	銅 SteelBrass	0.25	26-24 (0.12-0.2)	6.0	3.5			25K/R	B
	02	銅鍍錫 Tinned Brass								

接线包线端子 Button Terminals

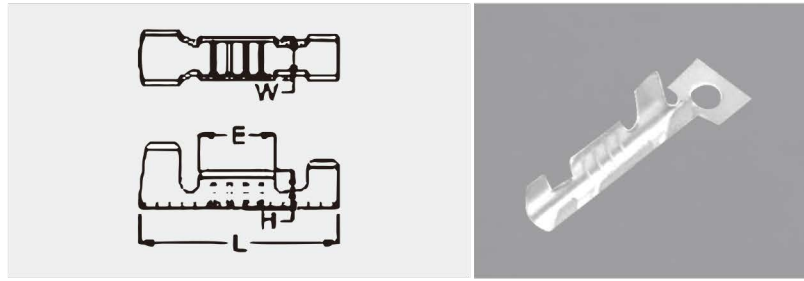

PartNo.型号	Material材质		MaterialThickness 料厚(mm)	WireRang(AWG) 电线范围(线号)	Dimension尺寸(mm)			Packing包装
					L	E	W	
NT 13900	01	銅 Brass	0.3	18-22 (0.83-0.33)	13.4	5.2	---	8K/R

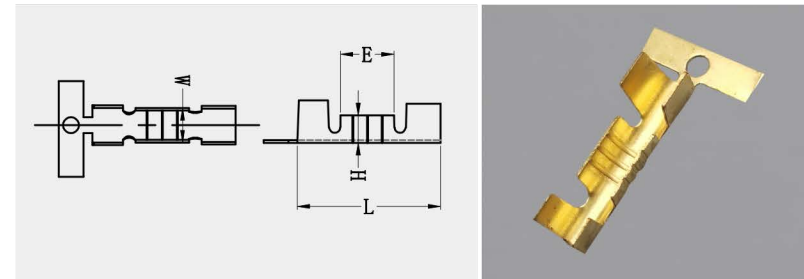

PartNo.型号	Material材质		MaterialThickness 料厚(mm)	WireRang(AWG) 电线范围(线号)	Dimension尺寸(mm)				Packing包装
					L	E	W	H	
NL 1390001-30C	01	銅Brass	0.3	18-22 (0.83-0.33)	15.9	6.0	3.9	3.1	

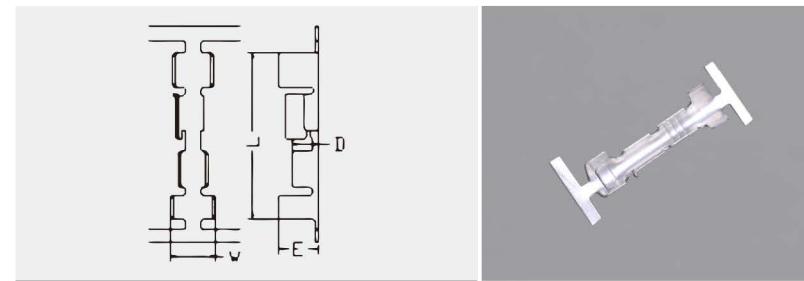

PartNo.型号	Material材质		MaterialThickness 料厚(mm)	WireRang(AWG) 电线范围(线号)	Dimension尺寸(mm)				Packing包装
					L	E	W	D	
NT 283100	01	銅 Brass	0.35	18-22 (0.83-0.33)	18.5	4.8	4.6	2.8	3K/R
	02	銅镀锡 Tinned Brass	0.35	18-22 (0.83-0.33)	18.5	4.8	4.6	2.8	3K/R

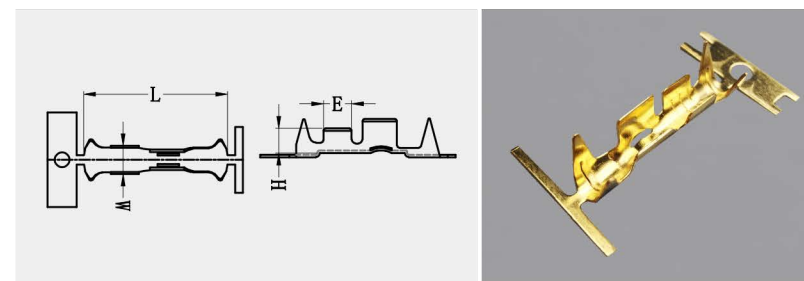

PartNo.型号	Material材质		MaterialThickness 料厚(mm)	WireRang(AWG) 电线范围(线号)	Dimension尺寸(mm)				Packing包装
					L	E	W	H	
NT 2830001-30C	01	銅 Brass	0.3	18-22 (0.83-0.33)	16.5	3.3	3.3	2.9	

接线包线端子 Button Terminals

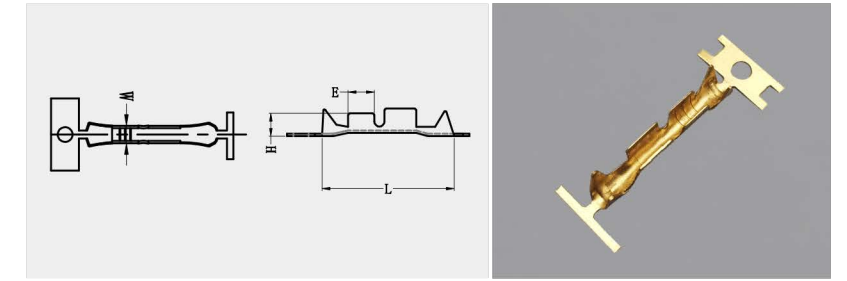

PartNo.型号	Material材质		MaterialThickness 料厚(mm)	WireRang(AWG) 电线范围(线号)	Dimension尺寸(mm)				Packing包装
					L	E	W	H	
NT 1831001-30C	01	銅 Brass	0.3	18-22 (0.83-0.33)	16.7	3.3	2.2	2.9	

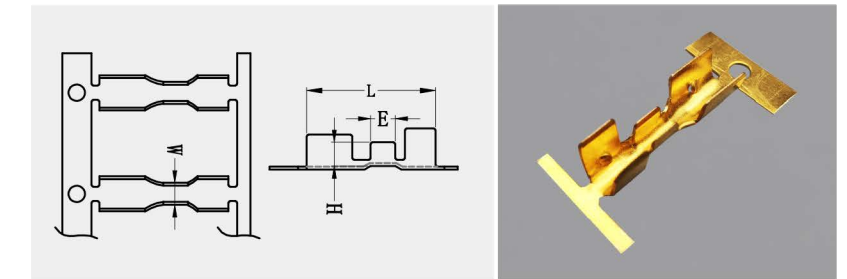

PartNo.型号	Material材质		MaterialThickness 料厚(mm)	WireRang(AWG) 电线范围(线号)	Dimension尺寸(mm)				Packing包装
					L	E	W	H	
NT 1380001-35C	01	銅 Brass	0.35	18-22 (0.83-0.33)	14.7	2.8	2.5	4.0	

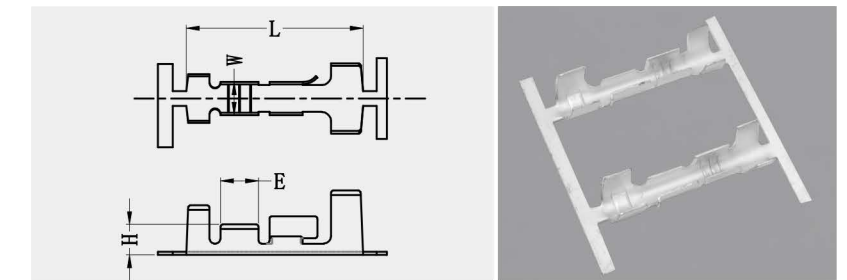

PartNo.型号	Material材质		MaterialThickness 料厚(mm)	WireRang(AWG) 电线范围(线号)	Dimension尺寸(mm)				Packing包装
					L	E	W	H	
NL 2831001-35C	01	銅 Brass	0.35	18-22 (0.83-0.33)	19	4.1	3.6	3.3	

鲨鱼齿 Shark Teeth Splicer

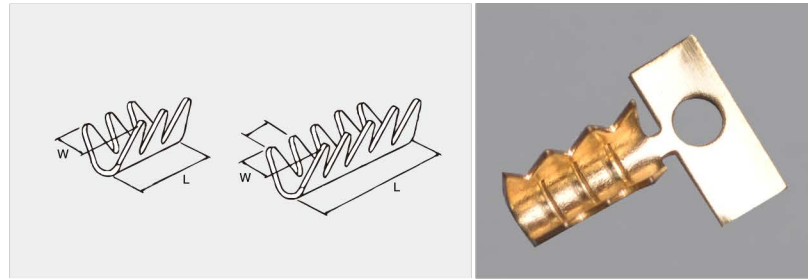

Part No. 型号	Material 材质			Material Thickness 料厚 (mm)	Wire Rang (AWG) 电线范围(线号)	Dimension 尺寸 (mm)		Packing 包装
						W	L	
TS 2mm	01	銅	Brass	0.3	18 - 20 (0.83 - 0.52)	2.6	6.0	250K/R
WS18060	01-S	銅	Brass	0.3	18 - 20 (0.83 - 0.52)	2.8	6.0	15K/R
WS18060	01-L	銅	Brass	0.30	16 - 18 (1.5 - 0.83)	3.3	6.3	15K/R
WS25090	01	銅	Brass	0.30	14 - 16 (2.5 - 1.5)	3	4	20K/R

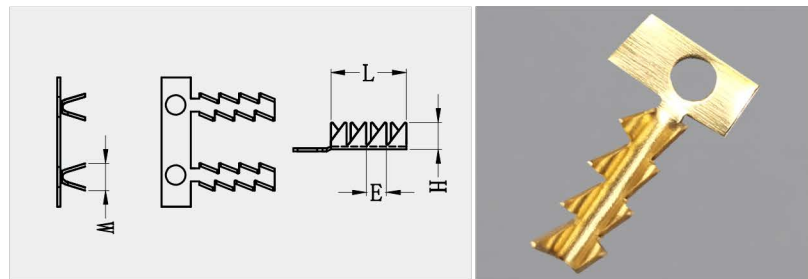

PartNo.型号	Material材质			MaterialThickness 料厚(mm)	WireRang(AWG) 电线范围(线号)	Dimension尺寸(mm)			Packing包装
						L	W	H	
WS1809001-30C	01	銅	Brass	0.3	18-22 (0.83-0.33)	7.8	2.6	2.7	12.5K/R

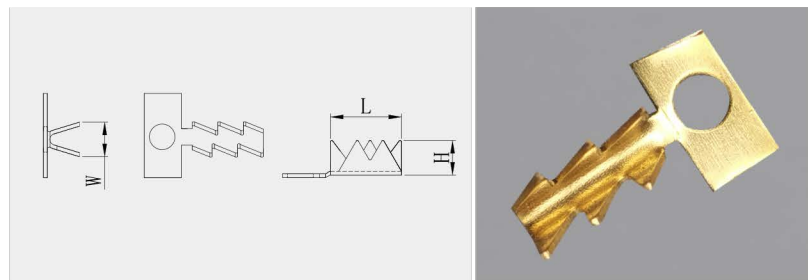

PartNo.型号	Material材质			MaterialThickness 料厚(mm)	WireRang(AWG) 电线范围(线号)	Dimension尺寸(mm)			Packing包装
						L	W	H	
Ws1805	01	銅	Brass	0.3	24-18 (0.2-0.83)	5.6	2.6	2.7	10K/R

鲨鱼齿 Shark Teeth Splicer

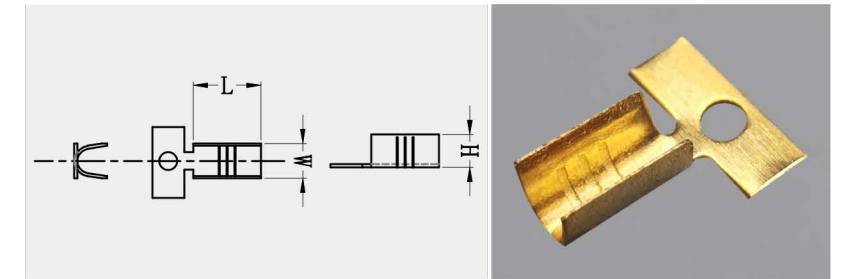

PartNo.型号	Material材质			MaterialThickness 料厚(mm)	WireRang(AWG) 电线范围(线号)	Dimension尺寸(mm)				Packing包装
						L	E	W	H	
WS600001-30C	01	銅	Brass	0.3	18-22 (0.83-0.33)	6.3	-	3.4	3.2	

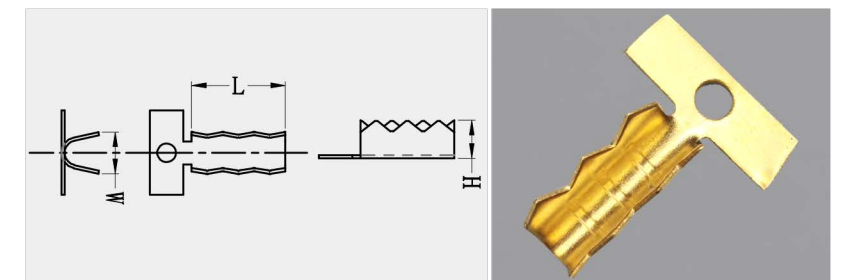

PartNo.型号	Material材质			MaterialThickness 料厚(mm)	WireRang(AWG) 电线范围(线号)	Dimension尺寸(mm)				Packing包装
						L	E	W	H	
2.5平方鲨鱼齿	01	銅	Brass	0.3	16-14 (1.5-2.5)	9	-	4	3.6	

汽车连续端子 Car Type Terminals

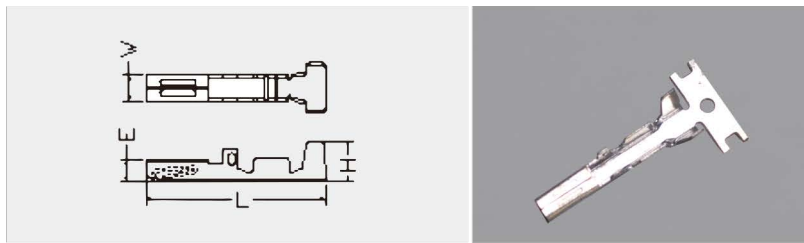

PartNo.型号	Material材质		MaterialThickness 料厚(mm)	WireRang(AWG) 电线范围(线号)	Dimension尺寸(mm)				Packing包装
					L	E	W	H	
CAR002-M	01	銅 Brass	0.3	18-20 (0.83 - 0.52)	23.9	0.7	0.8	4.2	3.5/R

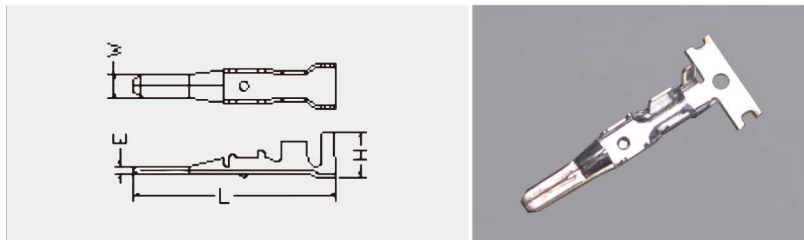

PartNo.型号	Material材质		MaterialThickness 料厚(mm)	WireRang(AWG) 电线范围(线号)	Dimension尺寸(mm)				Packing包装
					L	E	W	H	
CAR003-F	01	銅 Brass	0.40	18-20 (0.83 - 0.52)	22.8	0.85	2.7	5.0	3K/R

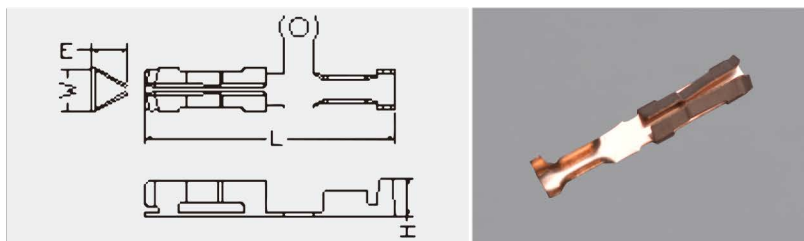

PartNo.型号	Material材质		MaterialThickness 料厚(mm)	WireRang(AWG) 电线范围(线号)	Dimension尺寸(mm)				Packing包装
					L	E	W	H	
三角母端	01	磷銅 Brass	0.3	22-16 (0.5 - 1.5)	26.0	3.70	4.5	4.0	3K/R

铜带 Splice Ribbon

PartNo.型号	Material材质		MaterialThickness 料厚(mm)	WireRang(AWG) 电线范围(线号)	Dimension 尺寸(mm)	Packing 包装
SR20030	01	Brass	0.3	DEPEND ON CRIMP TOOLS	2.0	260M/R
SR20040	01	Brass	0.4		2.0	260M/R
SR40030	01	Brass	0.3		4.0	260M/R
SR40040	01	Brass	0.4		4.0	200M/R
SR40040	02	Tinned Brass	0.4		4.0	200M/R
SR40040	03	Nickel Steel	0.4		4.0	200M/R
SR60030	01	Brass	0.3		6.0	130M/R
SR60040	01	Brass	0.4		6.0	130M/R
SR80030	01	Brass	0.3		8.0	130M/R
SR80030	02	Tinned Brass	0.3		8.0	130M/R

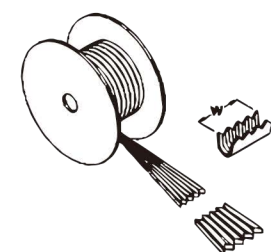

冷压端子 COLD PRESSED TERMINALS



无绝缘护套圆形端子

(适用于软线)

Non-Insulated Ring Terminal

(Apply in flexible wire)

材质: 紫铜 Terminal Body: Copper
表面处理: 镀锡 Plating: Tin

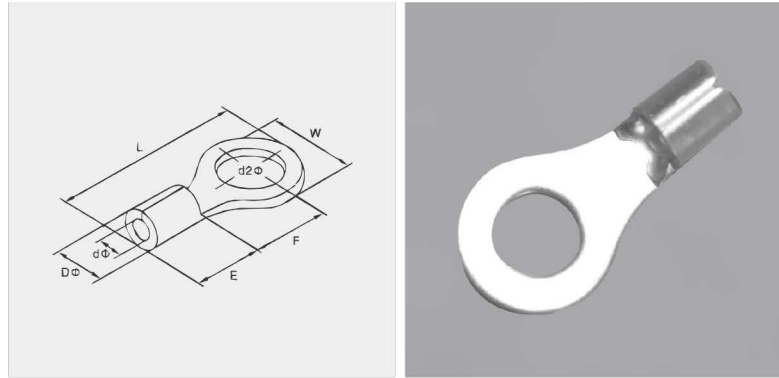

型号 Item NO	导线截面mm ² Cable Size A.W.G	材料厚度 Thickness (mm)	最大电流 Max Current	美制螺栓号 USA Screw	螺栓口直径 Screw Dia. d2(mm)	尺寸 Dimension(mm)					
						W	L	F	E	Dφ	dφ
RNB0.5-3	0.25-0.75 (24-18)	0.5	10A	#4	3.2	5.7	12.6	4.9	4.3	2.3	1.3
RNB0.5-3.5S				#6	3.7	5.7	12.6	4.9			
RNB0.5-3.5M				#6	3.7	6.6	14.1	6.3			
RNB0.5-4				#8	4.3	6.6	14.1	6.3			

型号 Item NO	导线截面mm ² Cable Size A.W.G	材料厚度 Thickness (mm)	最大电流 Max Current	美制螺栓号 USA Screw	螺栓口直径 Screw Dia. d2(mm)	尺寸 Dimension(mm)					
						W	L	F	E	Dφ	dφ
RNB 1.25-3	0.5-1.5 (22-16)	0.75	19A	#4	3.2	5.7	12.6	4.9	4.8	3.4	1.7
RNB 1.25-3.5 S				#6	3.7	5.7	12.6	4.9			
RNB 1.25-3.5 M				#6	3.7	6.6	14.4	6.3			
RNB 1.25-3.5 L				#6	3.7	8.0	15.8	7.0			
RNB 1.25-4 S				#8	4.3	6.6	14.4	6.3			
RNB 1.25-4 L				#8	4.3	8.0	15.8	7.0			
RNB 1.25-5 S				#10	5.3	8.0	15.8	7.0			
RNB 1.25-5 L				#10	5.3	9.8	17.6	8.2			
RNB 1.25-6 S				1/4	6.4	9.8	17.6	8.2			
RNB 1.25-6 L				1/4	6.4	11.6	21.8	11.1			
RNB 1.25-8				5/16	8.4	11.6	21.8	11.1			
RNB 1.25-10				3/8	10.5	13.6	25.5	13.9			
RNB 1.25-12	1/2	13.0	19.2	30.5	16.5						

型号 Item NO	导线截面mm ² Cable Size A.W.G	材料厚度 Thickness (mm)	最大电流 Max Current	美制螺栓号 USA Screw	螺栓口直径 Screw Dia. d2(mm)	尺寸 Dimension(mm)					
						W	L	F	E	Dφ	dφ
RNB 2-3	1.5-2.5 (16-14)	0.8	27A	#4	3.2	6.6	13.0	4.3	4.8	4.1	2.3
RNB 2-3.5S				#6	3.7	6.6	13.0	4.3			
RNB 2-3.5M				#6	3.7	6.6	14.5	6.5			
RNB 2-3.5L				#6	3.7	8.5	16.8	7.7			
RNB 2-4S				#8	4.3	6.6	14.5	6.5			
RNB 2-4 L				#8	4.3	8.5	16.8	7.7			
RNB 2-5 S				#10	5.3	8.5	16.8	7.7			
RNB 2-5 L				#10	5.3	9.5	16.8	7.2			
RNB 2-6 S				1/4	6.4	9.5	16.8	7.2			
RNB 2-6 L				1/4	6.4	12.0	21.8	11.0			
RNB 2-8				5/16	8.4	12.0	21.8	11.0			
RNB 2-10				3/8	10.5	14.6	26.0	13.9			
RNB 2-12	1/2	13.0	19.2	31.2	16.5						

无绝缘护套圆形端子

(适用于软线)

Non-Insulated Ring Terminal

(Apply in flexible wire)

材质: 紫铜 Terminal Body: Copper
表面处理: 镀锡 Plating: Tin

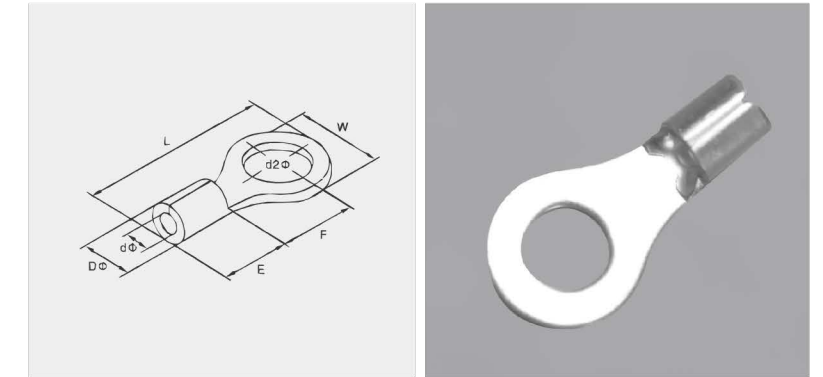

型号 Item NO	导线截面mm ² Cable Size A.W.G	材料厚度 Thickness (mm)	最大电流 Max Current	美制螺栓号 USA Screw	螺栓口直径 Screw Dia. d2(mm)	尺寸 Dimension(mm)					
						W	L	F	E	Dφ	dφ
RNB3.5-4	2.5-4.0 (14-12)	1.0	37A	#8	4.3	8.0	18.0	7.7	6.0	5.0	3.0
RNB3.5-5S				#10	5.3	8.0	18.0	7.7			
RNB3.5-5L				#10	5.3	12.0	21.4	8.6			
RNB3.5-6				1/4	6.4	12.0	21.4	8.6			
RNB3.5-8				5/16	8.4	15.0	27.5	14			
RNB3.5-10				3/8	10.5	15.0	27.5	14			

型号 Item NO	导线截面mm ² Cable Size A.W.G	材料厚度 Thickness (mm)	最大电流 Max Current	美制螺栓号 USA Screw	螺栓口直径 Screw Dia. d2(mm)	尺寸 Dimension(mm)					
						W	L	F	E	Dφ	dφ
RNB 5.5-3	4.0-6.0 (12-10)	1.0	48A	#4	3.2	7.2	16.2	5.9	6.8	5.6	3.4
RNB 5.5-3.5S				#6	3.7	7.2	16.2	5.9			
RNB 5.5-4S				#8	4.3	7.2	16.2	5.9			
RNB 5.5-4 L				#8	4.3	9.5	19.8	8.3			
RNB 5.5-5				#10	5.3	9.5	19.8	8.3			
RNB 5.5-6				1/4	6.4	12.0	23.5	11.0			
RNB 5.5-8				5/16	8.4	15.0	28.0	13.7			
RNB 5.5-10				3/8	10.5	15.0	28.0	13.7			
RNB 5.5-12				1/2	13.0	19.2	32.4	16.0			

型号 Item NO	导线截面mm ² Cable Size A.W.G	材料厚度 Thickness (mm)	最大电流 Max Current	美制螺栓号 USA Screw	螺栓口直径 Screw Dia. d2(mm)	尺寸 Dimension(mm)					
						W	L	F	E	Dφ	dφ
RNB 8-4	6.0-10 (8)	1.2	62A	#8	4.3	8.8	23.8	9.3	8.5	7.2	4.5
RNB 8-4L				#8	4.3	12.0	23.8	9.3			
RNB 8-5S				#10	5.3	8.8	23.8	9.3			
RNB 8-5M				#10	5.3	12.0	23.8	9.3			
RNB 8-5L				#10	5.3	15.0	29.8	13.8			
RNB 8-6S				1/4	6.4	12.0	23.8	9.3			
RNB 8-6L				1/4	6.4	15.0	29.8	13.8			
RNB 8-8				5/16	8.4	15.0	29.8	13.8			
RNB 8-10				3/8	10.5	15.0	29.8	13.8			
RNB 8-12				1/2	13.0	22.0	39.5	15.0			

无绝缘护套圆形端子

(适用于软线)

Non-Insulated Ring Terminal

(Apply in flexible wire)

材质: 紫铜 Terminal Body: Copper
表面处理: 镀锡 Plating: Tin

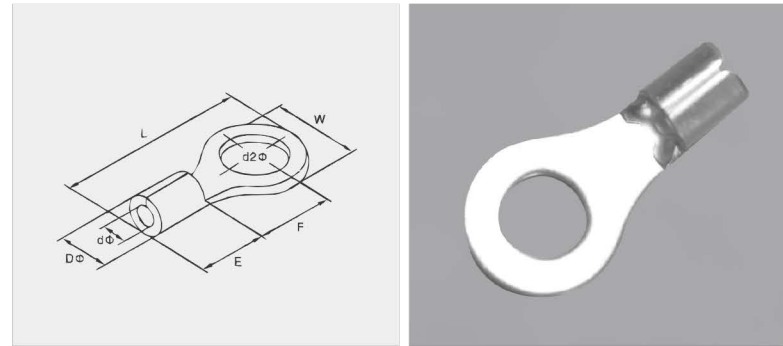

型号 Item NO	导线截面mm ² Cable Size A.W.G	材料厚度 Thickness (mm)	最大电流 Max Current	美制螺栓号 USA Screw	螺栓口直径 Screw Dia. d2(mm)	尺寸 Dimension(mm)					
						W	L	F	E	Dφ	dφ
RNB 14-4	10-16 (6)	1.4	88A	#8	4.3	12.0	29.8	13.3	10.5	9.0	6.2
RNB 14-5				#10	5.3	12.0	29.8	13.3			
RNB 14-6S				1/4	6.4	12.0	29.8	13.3			
RNB 14-6L				1/4	6.4	16.0	32.8	13.3			
RNB 14-8				5/16	8.4	16.0	32.8	14.5			
RNB 14-10				3/8	10.5	16.0	32.8	14.5			
RNB 14-12				1/2	13.0	22.0	41.0	19.5			
RNB 14-14				9/16	15.0	30.0	51.0	25.0			
RNB 14-16				5/8	17.0	30.0	51.0	26.0			
RNB 14-18				11/16	19.0	30.0	51.0	27.0			
RNB 14-20				3/4	21.0	30.0	51.0	28.0			

型号 Item NO	导线截面mm ² Cable Size A.W.G	材料厚度 Thickness (mm)	最大电流 Max Current	美制螺栓号 USA Screw	螺栓口直径 Screw Dia. d2(mm)	尺寸 Dimension(mm)					
						W	L	F	E	Dφ	dφ
RNB 22-5S	16-25 (4)	1.7	115A	#10	5.3	12.2	33.2	14.5	12.0	11.6	8.2
RNB 22-5L				#10	5.3	16.5	33.7	13.5			
RNB 22-6S				1/4	6.4	12.2	33.2	14.5			
RNB 22-6L				1/4	6.4	16.5	33.7	13.5			
RNB 22-8				5/16	8.4	16.5	33.7	13.5			
RNB 22-10				3/8	10.5	16.5	33.7	13.5			
RNB 22-12				1/2	13.0	22.0	42.5	19.5			
RNB 22-14				9/16	15.0	30.0	51.0	24.0			
RNB 22-16				5/8	17.0	30.0	51.0	25.0			
RNB 22-18				11/16	19.0	30.0	51.0	26.0			
RNB 22-20				3/4	21.0	30.0	51.0	27.0			

型号 Item NO	导线截面mm ² Cable Size A.W.G	材料厚度 Thickness (mm)	最大电流 Max Current	美制螺栓号 USA Screw	螺栓口直径 Screw Dia. d2(mm)	尺寸 Dimension(mm)					
						W	L	F	E	Dφ	dφ
RNB 38-5	35-50 (2)	1.8	160A	#10	5.3	15.3	39.0	18.3	14.0	13.3	9.4
RNB 38-6				1/4	6.4	15.3	39.0	18.3			
RNB 38-8S				5/16	8.4	15.3	39.0	18.3			
RNB 38-8L				5/16	8.4	22.0	42.7	17.7			
RNB 38-10S				3/8	10.5	15.3	39.0	18.3			
RNB 38-10L				3/8	10.5	22.0	42.7	17.7			
RNB 38-12				1/2	13.0	22.0	42.7	17.7			
RNB 38-14				9/16	15.0	30.0	52.2	22.5			
RNB 38-16				5/8	17.0	30.0	52.2	23.5			
RNB 38-18				11/16	19.0	30.0	52.2	24.5			
RNB 38-20				3/4	21.0	30.0	52.2	25.5			

无绝缘护套圆形端子

(适用于软线)

Non-Insulated Ring Terminal

(Apply in flexible wire)

材质: 紫铜 Terminal Body: Copper
表面处理: 镀锡 Plating: Tin

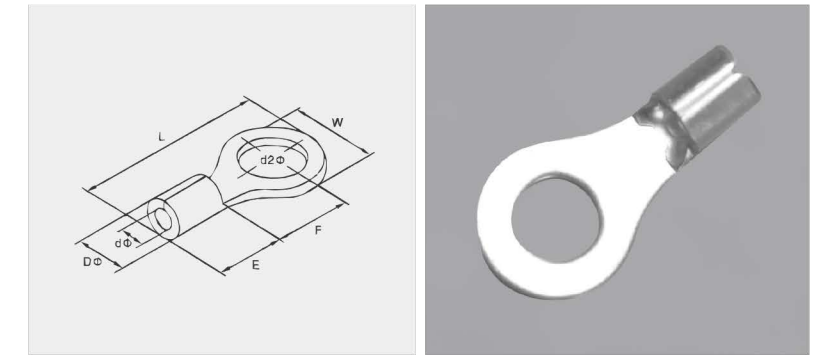

型号 Item NO	导线截面mm ² Cable Size A.W.G	材料厚度 Thickness (mm)	最大电流 Max Current	美制螺栓号 USA Screw	螺栓口直径 Screw Dia. d2(mm)	尺寸 Dimension(mm)					
						W	L	F	E	Dφ	dφ
RNB 60-6	50-70 (1/0)	1.7	215A	1/4	6.4	22.0	49.7	20.7	18.0	15.4	12.0
RNB 60-8				5/16	8.4						
RNB 60-10				3/8	10.5						
RNB 60-12				1/2	13.0						
RNB 60-14				9/16	15.0						
RNB 60-16				5/8	17.0						
RNB 60-18				11/16	19.0	32.0	57.5	23.5			
RNB 60-20				3/4	21.0						
RNB 60-22				7/8	23.0						

型号 Item NO	导线截面mm ² Cable Size A.W.G	材料厚度 Thickness (mm)	最大电流 Max Current	美制螺栓号 USA Screw	螺栓口直径 Screw Dia. d2(mm)	尺寸 Dimension(mm)					
						W	L	F	E	Dφ	dφ
RNB 70-6	70-95 (2/0)	2.0	235A	1/4	6.4	24.0	51.0	20.0	19.0	17.5	13.5
RNB 70-8				5/16	8.4						
RNB 70-10				3/8	10.5						
RNB 70-12				1/2	13.0						
RNB 70-14				9/16	15.0						
RNB 70-16				5/8	17.0						
RNB 70-18				11/16	19.0	32.0	61.0	26.0			
RNB 70-20				3/4	21.0						
RNB 70-22				7/8	23.0						

型号 Item NO	导线截面mm ² Cable Size A.W.G	材料厚度 Thickness (mm)	最大电流 Max Current	美制螺栓号 USA Screw	螺栓口直径 Screw Dia. d2(mm)	尺寸 Dimension(mm)					
						W	L	F	E	Dφ	dφ
RNB 80-6	95-120 (3/0)	2.2	255A	1/4	6.4	27.0	54.2	20.7	20.0	19.5	15.0
RNB 80-8				5/16	8.4						
RNB 80-10				3/8	10.5						
RNB 80-12				1/2	13.0						
RNB 80-14				9/16	15.0						
RNB 80-16				5/8	17.0						
RNB 80-18				11/16	19.0	32.0	68.0	32.0			
RNB 80-20				3/4	21.0						
RNB 80-22				7/8	23.0						

无绝缘护套圆形端子

(适用于软线)

Non-Insulated Ring Terminal

(Apply in flexible wire)

材质: 紫铜 Terminal Body: Copper
表面处理: 镀锡 Plating: Tin

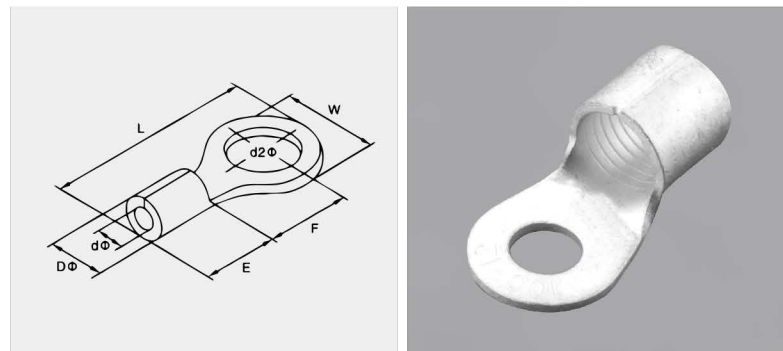

型号 Item NO	导线截面mm ² Cable Size A.W.G	材料厚度 Thickness (mm)	最大电流 Max Current	美制螺栓号 USA Screw	螺栓口直径 Screw Dia. d2(mm)	尺寸 Dimension(mm)					
						W	L	F	E	Dφ	dφ
RNB 100-6	120-150 (4/0)	2.6	300A	1/4	6.4	28.5	55.6	20.4	21.0	22.5	17.0
RNB 100-8				5/16	8.4						
RNB 100-10				3/8	10.5						
RNB 100-12				1/2	13.0	32.0	69.0	32.0	21.0	22.5	17.0
RNB 100-14				9/16	15.0						
RNB 100-16				5/8	17.0						
RNB 100-18				11/16	19.0						
RNB 100-20				3/4	21.0						
RNB 100-22				7/8	23.0						

型号 Item NO	导线截面mm ² Cable Size A.W.G	材料厚度 Thickness (mm)	最大电流 Max Current	美制螺栓号 USA Screw	螺栓口直径 Screw Dia. d2(mm)	尺寸 Dimension(mm)					
						W	L	F	E	Dφ	dφ
RNB 150-8	150-185 (250-300)	3.2	395A	5/16	8.4	36.5	66.0	23.0	27.0	27.0	20.0
RNB 150-10				3/8	10.5						
RNB 150-12				1/2	13.0						
RNB 150-14				9/16	15.0	36.0	81.0	36.0	27.0	27.0	20.0
RNB 150-16				5/8	17.0						
RNB 150-18				11/16	19.0						
RNB 150-20				3/4	21.0						
RNB 150-22				7/8	23.0						
RNB 150-24				15/16	25.0						
RNB 150-27	1	28.0									

型号 Item NO	导线截面mm ² Cable Size A.W.G	材料厚度 Thickness (mm)	最大电流 Max Current	美制螺栓号 USA Screw	螺栓口直径 Screw Dia. d2(mm)	尺寸 Dimension(mm)					
						W	L	F	E	Dφ	dφ
RNB 180-8	185-240 (300-350)	3.5	440A	5/16	8.4	38.5	69.0	24.5	28.5	28.6	21.0
RNB 180-10				3/8	10.5						
RNB 180-12				1/2	13.0						
RNB 180-14				9/16	15.0	38.5	86.6	39.0	28.5	28.6	21.0
RNB 180-16				5/8	17.0						
RNB 180-18				11/16	19.0						
RNB 180-20				3/4	21.0						
RNB 180-22				7/8	23.0						
RNB 180-24				15/16	25.0						
RNB 180-27	1	28.0									

无绝缘护套圆形端子

(适用于软线)

Non-Insulated Ring Terminal

(Apply in flexible wire)

材质: 紫铜 Terminal Body: Copper
表面处理: 镀锡 Plating: Tin

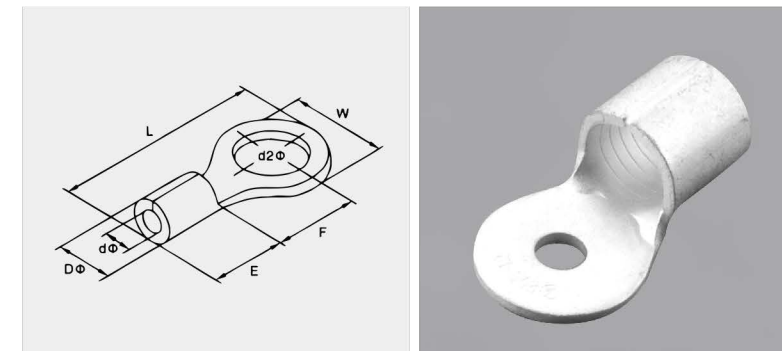

型号 Item NO	导线截面mm ² Cable Size A.W.G	材料厚度 Thickness (mm)	最大电流 Max Current	美制螺栓号 USA Screw	螺栓口直径 Screw Dia. d2(mm)	尺寸 Dimension(mm)					
						W	L	F	E	Dφ	dφ
RNB 200-8	240-400 (250-300)	4.0	470A	5/16	8.4	44.0	78.0	24.5	31.5	32.6	24.0
RNB 200-10				3/8	10.5						
RNB 200-12				1/2	13.0						
RNB 200-14				9/16	15.0	44.0	91.0	37.5	31.5	32.6	24.0
RNB 200-16				5/8	17.0						
RNB 200-18				11/16	19.0						
RNB 200-20				3/4	21.0						
RNB 200-22				7/8	23.0						
RNB 200-24				15/16	25.0						
RNB 200-27				1	28.0						

型号 Item NO	导线截面mm ² Cable Size A.W.G	材料厚度 Thickness (mm)	最大电流 Max Current	美制螺栓号 USA Screw	螺栓口直径 Screw Dia. d2(mm)	尺寸 Dimension(mm)					
						W	L	F	E	Dφ	dφ
RNB 325-8	300-400 (500-600)	4.2	650A	5/16	8.4	50.5	87.5	33.5	35.5	37.1	28.5
RNB 325-10				3/8	10.5						
RNB 325-12				1/2	13.0						
RNB 325-14				9/16	15.0	50.5	105.7	45.0	35.5	37.1	28.5
RNB 325-16				5/8	17.0						
RNB 325-18				11/16	19.0						
RNB 325-20				3/4	21.0						
RNB 325-22				7/8	23.0						
RNB 325-24				15/16	25.0						
RNB 325-27				1	28.0						

PVC绝缘护套圆形端子

(适用于软线)

Vinyl-Insulated Ring Terminal

(Apply in flexible wire)

材质: 紫铜 Terminal Body: Copper
 护套: PVC Insulation: Vinyl
 表面处理: 镀锡 Plating: Tin

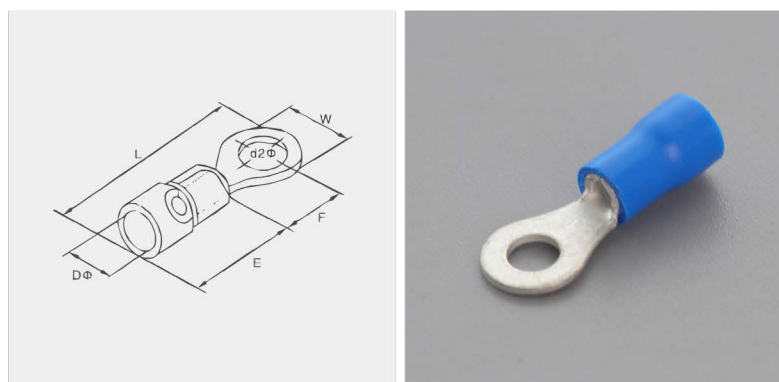

型号 Item NO	导线截面mm ² Cable Size A.W.G	材料厚度 Thickness (mm)	最大电流 Max Current	美制螺栓号 USA Screw	螺栓口直径 Screw Dia. d2(mm)	尺寸 Dimension(mm)					颜色 Color
						W	L	F	E	Dφ	
RV0.5-3	0.25-0.75 (24-18)	0.5	10A	#4	3.2	5.7	18.3	4.9	10.0	2.7	黄 Yellow
RV0.5-3.5S				#6	3.7	5.7	18.3	4.9			
RV0.5-3.5M				#6	3.7	6.6	19.9	6.3			
RV0.5-4				#8	4.3	6.6	19.9	6.3			

型号 Item NO	导线截面mm ² Cable Size A.W.G	材料厚度 Thickness (mm)	最大电流 Max Current	美制螺栓号 USA Screw	螺栓口直径 Screw Dia. d2(mm)	尺寸 Dimension(mm)					颜色 Color
						W	L	F	E	Dφ	
RV 1.25-3	0.5-1.5 (22-16)	0.75	19A	#4	3.2	5.7	17.8	4.9	10.7	4.2	红 Red
RV 1.25-3.5 S				#6	3.7	5.7	17.8	4.9			
RV 1.25-3.5 M				#6	3.7	6.6	20.1	6.3			
RV 1.25-3.5 L				#6	3.7	8.0	21.5	7.0			
RV 1.25-4 S				#8	4.3	6.6	20.1	6.3			
RV 1.25-4 L				#8	4.3	8.0	21.5	7.0			
RV 1.25-5 S				#10	5.3	8.0	21.5	7.0			
RV 1.25-5 L				#10	5.3	9.8	23.0	8.2			
RV 1.25-6 S				1/4	6.4	9.8	23.0	8.2			
RV 1.25-6 L				1/4	6.4	11.6	27.5	11.1			
RV 1.25-8				5/16	8.4	11.6	27.5	11.1			
RV 1.25-10				3/8	10.5	13.6	31.6	13.9			
RV 1.25-12	1/2	13.0	19.2	36.0	16.5						

型号 Item NO	导线截面mm ² Cable Size A.W.G	材料厚度 Thickness (mm)	最大电流 Max Current	美制螺栓号 USA Screw	螺栓口直径 Screw Dia. d2(mm)	尺寸 Dimension(mm)					颜色 Color
						W	L	F	E	Dφ	
RV 2-3	1.5-2.5 (16-14)	0.8	27A	#4	3.2	6.6	17.8	4.3	10.7	4.9	蓝 Blue
RV 2-3.5 S				#6	3.7	6.6	17.8	4.3			
RV 2-3.5 M				#6	3.7	6.6	20.0	6.5			
RV 2-3.5 L				#6	3.7	8.5	22.5	7.7			
RV 2-4 S				#8	4.3	6.6	20.0	6.5			
RV 2-4 L				#8	4.3	8.5	22.5	7.7			
RV 2-5 S				#10	5.3	8.5	22.5	7.7			
RV 2-5 L				#10	5.3	9.5	22.5	7.2			
RV 2-6 S				1/4	6.4	9.5	22.5	7.2			
RV 2-6 L				1/4	6.4	12.0	27.6	11.0			
RV 2-8				5/16	8.4	12.0	27.6	11.0			
RV 2-10				3/8	10.5	14.6	31.2	13.9			
RV 2-12	1/2	13.0	19.2	36.5	16.5						

PVC绝缘护套圆形端子

(适用于软线)

Vinyl-Insulated Ring Terminal

(Apply in flexible wire)

材质: 紫铜 Terminal Body: Copper
 护套: PVC Insulation: Vinyl
 表面处理: 镀锡 Plating: Tin

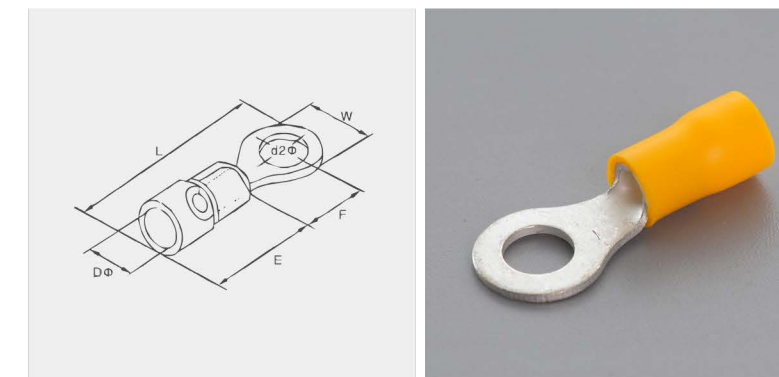

型号 Item NO	导线截面mm ² Cable Size A.W.G	材料厚度 Thickness (mm)	最大电流 Max Current	美制螺栓号 USA Screw	螺栓口直径 Screw Dia. d2(mm)	尺寸 Dimension(mm)					颜色 Color
						W	L	F	E	Dφ	
RV3.5-4	2.5-4.0 (14-12)	1.0	37A	#8	4.3	8.0	24.5	7.7	13.8	5.8	黑 Black
RV3.5-5S				#10	5.3	8.0	24.5	7.7			
RV3.5-5L				#10	5.3	12.0	27.9	8.6			
RV3.5-6				1/4	6.4	12.0	27.9	8.6			
RV3.5-8				5/16	8.4	15.0	34	14			
RV3.5-10				3/8	10.5	15.0	34	14			

型号 Item NO	导线截面mm ² Cable Size A.W.G	材料厚度 Thickness (mm)	最大电流 Max Current	美制螺栓号 USA Screw	螺栓口直径 Screw Dia. d2(mm)	尺寸 Dimension(mm)					颜色 Color
						W	L	F	E	Dφ	
RV 5.5-3	4.0-6.0 (12-10)	1.0	48A	#4	3.2	7.2	22.7	5.9	14.0	6.5	黄 Yellow
RV 5.5-3.5S				#6	3.7	7.2	22.7	5.9			
RV 5.5-4S				#8	4.3	7.2	22.7	5.9			
RV 5.5-4 L				#8	4.3	9.5	26.3	8.3			
RV 5.5-5				#10	5.3	9.5	26.3	8.3			
RV 5.5-6				1/4	6.4	12.0	30.0	11.0			
RV 5.5-8				5/16	8.4	15.0	34.7	13.7			
RV 5.5-10				3/8	10.5	15.0	34.7	13.7			
RV 5.5-12				1/2	13.0	19.2	39.0	16.0			

型号 Item NO	导线截面mm ² Cable Size A.W.G	材料厚度 Thickness (mm)	最大电流 Max Current	美制螺栓号 USA Screw	螺栓口直径 Screw Dia. d2(mm)	尺寸 Dimension(mm)					颜色 Color
						W	L	F	E	Dφ	
RV 8-4	6.0-10 (8)	1.2	62A	#8	4.3	8.8	32.3	9.2	17.0	8.0	红 Red
RV 8-5S				#10	5.3	8.8	32.3	9.2			
RV 8-5M				#10	5.3	12.0	32.3	9.2			
RV 8-5L				#10	5.3	15.0	38.3	13.8			
RV 8-6S				1/4	6.4	12.0	32.3	9.8			
RV 8-6L				1/4	6.4	15.0	38.3	13.8			
RV 8-8				5/16	8.4	15.0	38.3	13.8			
RV 8-10				3/8	10.5	15.0	38.3	13.8			
RV 8-12	1/2	13.0	22.0	48.0	15.0						

尼龙绝缘护套圆形端子

(适用于软线)

Nylon-Insulated Ring Terminal

(Apply in flexible wire)

材质: 紫铜 Terminal Body: Copper
 护套: 尼龙 Insulation: Nylon
 温度: 105°C Temperature: 105°C
 表面处理: 镀锡 Plating: Tin

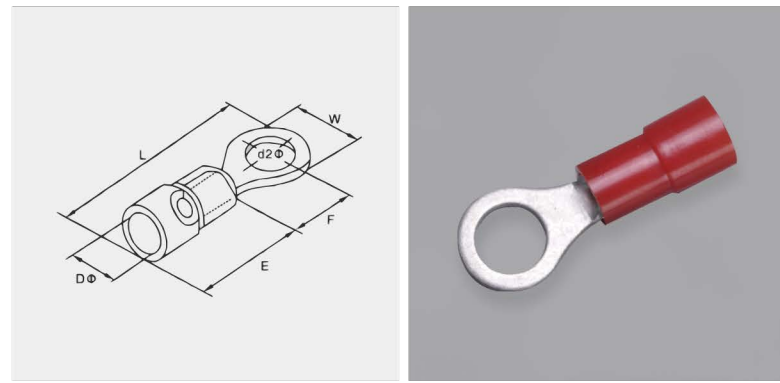

型号 Item NO	导线截面mm ² Cable Size A.W.G	材料厚度 Thickness (mm)	最大电流 Max Current	美制螺栓号 USA Screw	螺栓口直径 Screw Dia. d2(mm)	尺寸 Dimension(mm)					颜色 Color
						W	L	F	E	Dφ	
RVN 1.25-3	0.5-1.5 (22-16)	0.75	19A	#4	3.2	5.7	18.5	4.9	11.0	4.3	红 Red
RVN 1.25-3.5 S				#6	3.7	5.7	18.5	4.9			
RVN 1.25-3.5 M				#6	3.7	6.6	20.8	6.3			
RVN 1.25-3.5 L				#6	3.7	8.0	22.2	7.0			
RVN 1.25-4 S				#8	4.3	6.6	20.8	6.3			
RVN 1.25-4 L				#8	4.3	8.0	22.2	7.0			
RVN 1.25-5 S				#10	5.3	8.0	22.2	7.0			
RVN 1.25-5 L				#10	5.3	9.8	23.7	8.5			
RVN 1.25-6 S				1/4	6.4	9.8	23.7	8.5			
RVN 1.25-6 L				1/4	6.4	11.6	28.2	11.1			
RVN 1.25-8				5/16	8.4	11.6	28.2	11.1			
RVN 1.25-10				3/8	10.5	13.6	32.3	13.9			
RVN 1.25-12	1/2	13.0	19.2	36.7	16.5						

型号 Item NO	导线截面mm ² Cable Size A.W.G	材料厚度 Thickness (mm)	最大电流 Max Current	美制螺栓号 USA Screw	螺栓口直径 Screw Dia. d2(mm)	尺寸 Dimension(mm)					颜色 Color
						W	L	F	E	Dφ	
RVN 2-3	1.5-2.5 (16-14)	0.8	27A	#4	3.2	6.6	18.2	4.3	11.0	4.9	蓝 Blue
RVN 2-3.5 S				#6	3.7	6.6	18.2	4.3			
RVN 2-3.5 M				#6	3.7	6.6	20.5	6.5			
RVN 2-3.5 L				#6	3.7	8.5	23.0	7.7			
RVN 2-4 S				#8	4.3	6.6	20.5	6.5			
RVN 2-4 L				#8	4.3	8.5	23.0	7.7			
RVN 2-5 S				#10	5.3	8.5	23.0	7.7			
RVN 2-5 L				#10	5.3	9.5	23.0	7.2			
RVN 2-6 S				1/4	6.4	9.5	23.0	7.2			
RVN 2-6 L				1/4	6.4	12.0	28.1	11.0			
RVN 2-8				5/16	8.4	12.0	28.1	11.0			
RVN 2-10				3/8	10.5	14.6	31.7	13.9			
RVN 2-12	1/2	13.0	19.2	37.0	16.5						

尼龙绝缘护套圆形端子

(适用于软线)

Nylon-Insulated Ring Terminal

(Apply in flexible wire)

材质: 紫铜 Terminal Body: Copper
 护套: 尼龙 Insulation: Nylon
 温度: 105°C Temperature: 105°C
 表面处理: 镀锡 Plating: Tin

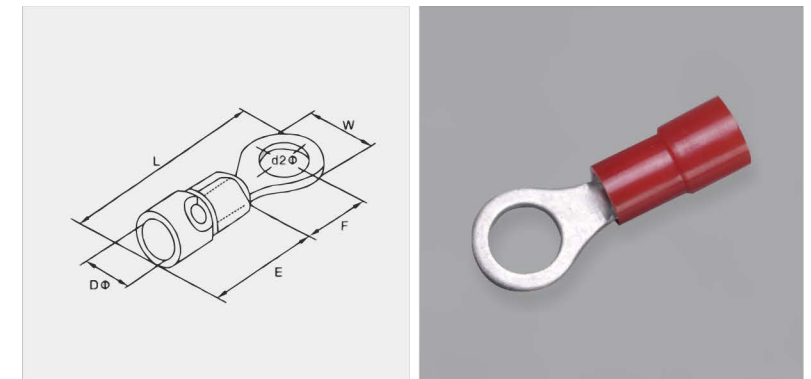

型号 Item NO	导线截面mm ² Cable Size A.W.G	材料厚度 Thickness (mm)	最大电流 Max Current	美制螺栓号 USA Screw	螺栓口直径 Screw Dia. d2(mm)	尺寸 Dimension(mm)					颜色 Color
						W	L	F	E	Dφ	
RVN 3.5-4	2.5-4.0 (14-12)	1.0	37A	#8	4.3	8.0	25.2	7.7	13.3	6.0	黑 Black
RVN 3.5-5 S				#10	5.3	8.0	25.2	7.7			
RVN 3.5-5 L				#10	5.3	12.0	28.6	8.6			
RVN 3.5-6				1/4	6.4	12.0	28.6	8.6			
RVN 3.5-8				5/16	8.4	15.0	34.7	14			
RVN 3.5-10				3/8	10.5	15.0	34.7	14			

型号 Item NO	导线截面mm ² Cable Size A.W.G	材料厚度 Thickness (mm)	最大电流 Max Current	美制螺栓号 USA Screw	螺栓口直径 Screw Dia. d2(mm)	尺寸 Dimension(mm)					颜色 Color
						W	L	F	E	Dφ	
RVN 5.5-3	4-6 (12-10)	1.0	48A	#4	3.2	7.2	22.0	5.9	14.0	6.6	黄 Yellow
RVN 5.5-3.5				#6	3.7	7.2	22.0	5.9			
RVN 5.5-4 S				#8	4.3	7.2	22.0	5.9			
RVN 5.5-4 L				#8	4.3	9.5	26.1	8.3			
RVN 5.5-5				#10	5.3	9.5	26.1	8.3			
RVN 5.5-6				1/4	6.4	12.0	32.1	13.0			
RVN 5.5-8				5/16	8.4	15.0	34.4	13.7			
RVN 5.5-10				3/8	10.5	15.0	34.4	13.7			
RVN 5.5-12				1/2	13.0	19.2	38.8	16.0			

尼龙绝缘护套圆形端子

(加铜套)(适用于软线)

Nylon -Insulated Ring Terminal
(Double Copper Sleeve) (Apply in flexible wire)

材质: 紫铜 Terminal Body: Copper
 护套: 尼龙 Insulation: Nylon
 温度: 105°C Temperature : 105°C
 表面处理: 镀锡 Plating : Tin

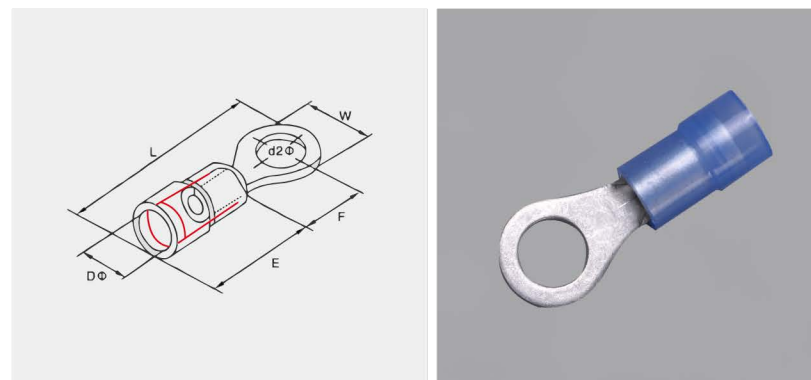

型号 Item NO	导线截面mm ² Cable Size A.W.G	材料厚度 Thickness (mm)	最大电流 Max Current	美制螺栓号 USA Screw	螺栓口直径 Screw Dia. d2(mm)	尺寸 Dimension(mm)					颜色 Color
						W	L	F	E	Dφ	
RVN 1.25-3 D	0.5-1.5 (22-16)	0.75	19A	#4	3.2	5.7	18.5	4.9	11.0	3.8	红 Red
RVN 1.25-3.5 S D				#6	3.7	5.7	18.5	4.9			
RVN 1.25-3.5 M D				#6	3.7	6.6	20.8	6.3			
RVN 1.25-3.5 L D				#6	3.7	8.0	22.2	7.0			
RVN 1.25-4 S D				#8	4.3	6.6	20.8	6.3			
RVN 1.25-4 L D				#8	4.3	8.0	22.2	7.0			
RVN 1.25-5 S D				#10	5.3	8.0	22.2	7.0			
RVN 1.25-5 L D				#10	5.3	9.8	23.7	8.5			
RVN 1.25-6 S D				1/4	6.4	9.8	23.7	8.5			
RVN 1.25-6 L D				1/4	6.4	11.6	28.2	11.1			
RVN 1.25-8 D				5/16	8.4	11.6	28.2	11.1			
RVN 1.25-10 D				3/8	10.5	13.6	32.3	13.9			
RVN 1.25-12 D				1/2	13.0	19.2	36.7	16.5			

型号 Item NO	导线截面mm ² Cable Size A.W.G	材料厚度 Thickness (mm)	最大电流 Max Current	美制螺栓号 USA Screw	螺栓口直径 Screw Dia. d2(mm)	尺寸 Dimension(mm)					颜色 Color
						W	L	F	E	Dφ	
RVN 2-3 D	1.5-2.5 (16-14)	0.8	27A	#4	3.2	6.6	18.2	4.3	11.0	4.4	蓝 Blue
RVN 2-3.5 S D				#6	3.7	6.6	18.2	4.3			
RVN 2-3.5 M D				#6	3.7	6.6	20.5	6.5			
RVN 2-3.5 L D				#6	3.7	8.5	23.0	7.7			
RVN 2-4 S D				#8	4.3	6.6	20.5	6.5			
RVN 2-4 L D				#8	4.3	8.5	23.0	7.7			
RVN 2-5 S D				#10	5.3	8.5	23.0	7.7			
RVN 2-5 L D				#10	5.3	9.5	23.0	7.2			
RVN 2-6 S D				1/4	6.4	9.5	23.0	7.2			
RVN 2-6 L D				1/4	6.4	12.0	28.1	11.0			
RVN 2-8 D				5/16	8.4	12.0	28.1	11.0			
RVN 2-10 D				3/8	10.5	14.6	31.7	13.9			
RVN 2-12 D				1/2	13.0	19.2	37.0	16.5			

尼龙绝缘护套圆形端子

(加铜套)(适用于软线)

Nylon -Insulated Ring Terminal
(Double Copper Sleeve) (Apply in flexible wire)

材质: 紫铜 Terminal Body: Copper
 护套: 尼龙 Insulation: Nylon
 温度: 105°C Temperature : 105°C
 表面处理: 镀锡 Plating : Tin

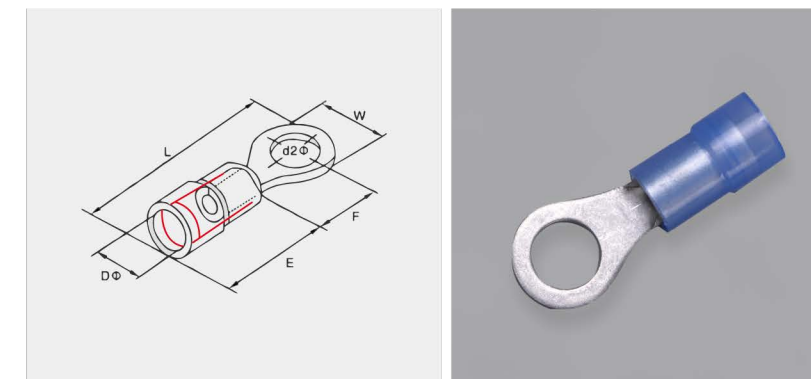

型号 Item NO	导线截面mm ² Cable Size A.W.G	材料厚度 Thickness (mm)	最大电流 Max Current	美制螺栓号 USA Screw	螺栓口直径 Screw Dia. d2(mm)	尺寸 Dimension(mm)					颜色 Color
						W	L	F	E	Dφ	
RVN 3.5-4 D	2.5-4.0 (14-12)	1.0	37A	#8	4.3	8.0	25.2	7.7	13.3	5.4	黑 Black
RVN 3.5-5 S D				#10	5.3	8.0	25.2	7.7			
RVN 3.5-5 L D				#10	5.3	12.0	28.6	7.7			
RVN 3.5-6 D				1/4	6.4	12.0	28.6	7.7			
RVN 3.5-8 D				5/16	8.4	15.0	34.7	14			
RVN 3.5-10 D				3/8	10.5	15.0	34.7	14			

型号 Item NO	导线截面mm ² Cable Size A.W.G	材料厚度 Thickness (mm)	最大电流 Max Current	美制螺栓号 USA Screw	螺栓口直径 Screw Dia. d2(mm)	尺寸 Dimension(mm)					颜色 Color
						W	L	F	E	Dφ	
RVN 5.5-3 D	4-6 (12-10)	1.0	48A	#4	3.2	7.2	22.0	5.9	14.0	6.1	黄 Yellow
RVN 5.5-3.5 S D				#6	3.7	7.2	22.0	5.9			
RVN 5.5-4 S D				#8	4.3	7.2	22.0	5.9			
RVN 5.5-4 L D				#8	4.3	9.5	26.1	8.3			
RVN 5.5-5 D				#10	5.3	9.5	26.1	8.3			
RVN 5.5-6 D				1/4	6.4	12.0	32.1	13.0			
RVN 5.5-8 D				5/16	8.4	15.0	34.4	13.7			
RVN 5.5-10 D				3/8	10.5	15.0	34.4	13.7			

无绝缘护套叉形端子

(适用于软线)

Non-Insulated Spade Terminal

(Apply in flexible wire)

材质: 紫铜

表面处理: 镀锡

Terminal Body: Copper

Plating: Tin

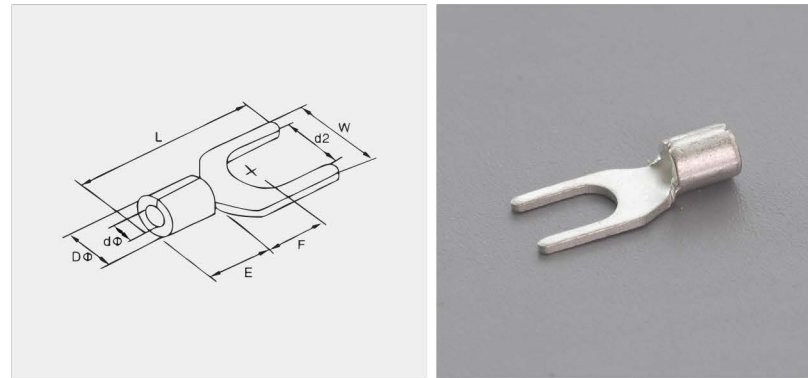

型号 Item NO	导线截面mm ² Cable Size A.W.G	材料厚度 Thickness (mm)	最大电流 Max Current	美制螺栓号 USA Screw	螺栓口直径 Screw Dia. d2(mm)	尺寸 Dimension(mm)					
						W	L	F	E	Dφ	dφ
SNB 0.5-3	0.2-0.75 (24-18)	0.5	10A	#4	3.2	5.7	14.2	5.1	4.3	2.3	1.7
SNB 0.5-4				#8	4.3	6.4	14.2	5.3			

型号 Item NO	导线截面mm ² Cable Size A.W.G	材料厚度 Thickness (mm)	最大电流 Max Current	美制螺栓号 USA Screw	螺栓口直径 Screw Dia. d2(mm)	尺寸 Dimension(mm)					
						W	L	F	E	Dφ	dφ
SNB 1.25-3	0.5-1.5 (22-16)	0.75	19A	#4	3.2	5.7	16.0	6.5	4.8	3.4	1.7
SNB 1.25-3.5 S				#6	3.7	5.7	16.0	6.5			
SNB 1.25-3.5 L				#6	3.7	6.4	16.0	6.5			
SNB 1.25-4 S				#8	4.3	6.4	16.0	6.5			
SNB 1.25-4 M				#8	4.3	7.2	16.0	6.5			
SNB 1.25-4 L				#8	4.3	8.1	16.0	6.5			
SNB 1.25-5 S				#10	5.3	8.1	16.0	6.5			
SNB 1.25-5 L				#10	5.3	9.5	16.0	6.5			
SNB 1.25-6 S				1/4	6.4	9.5	16.0	6.5			
SNB 1.25-6 L				1/4	6.4	12.0	22.0	11.0			

型号 Item NO	导线截面mm ² Cable Size A.W.G	材料厚度 Thickness (mm)	最大电流 Max Current	美制螺栓号 USA Screw	螺栓口直径 Screw Dia. d2(mm)	尺寸 Dimension(mm)					
						W	L	F	E	Dφ	dφ
SNB 2-3	1.5-2.5 (16-14)	0.8	27A	#4	3.2	5.7	16.0	6.5	4.8	4.1	2.3
SNB 2-3.5 S				#6	3.7	5.7	16.0	6.5			
SNB 2-3.5 L				#6	3.7	6.2	16.0	6.5			
SNB 2-4 S				#8	4.3	6.4	16.0	6.5			
SNB 2-4 M				#8	4.3	7.2	16.0	6.5			
SNB 2-4 L				#8	4.3	8.1	16.0	6.5			
SNB 2-5 S				#10	5.3	8.1	16.0	6.5			
SNB 2-5 L				#10	5.3	9.5	16.0	6.5			
SNB 2-6 S				1/4	6.4	9.5	16.0	6.5			
SNB 2-6 L				1/4	6.4	12.0	22.0	11.0			

无绝缘护套叉形端子

(适用于软线)

Non-Insulated Spade Terminal

(Apply in flexible wire)

材质: 紫铜

表面处理: 镀锡

Terminal Body: Copper

Plating: Tin

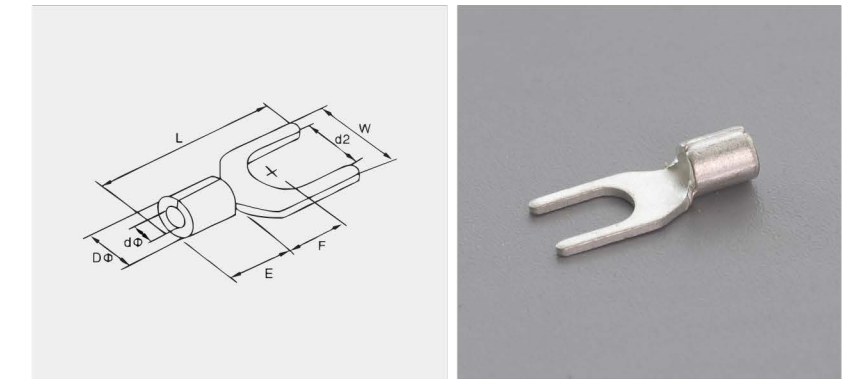

型号 Item NO	导线截面mm ² Cable Size A.W.G	材料厚度 Thickness (mm)	最大电流 Max Current	美制螺栓号 USA Screw	螺栓口直径 Screw Dia. d2(mm)	尺寸 Dimension(mm)					
						W	L	F	E	Dφ	dφ
SNB 3.5-3	2.5-4 (14-12)	1.0	37A	#4	3.2	5.7	18.3	7.0	6.0	5.0	3.0
SNB 3.5-4 S				#8	4.3	7.2	18.3	7.0			
SNB 3.5-4				#8	4.3	8.0	18.3	7.0			
SNB 3.5-5				#10	5.3	8.0	18.3	7.0			
SNB 3.5-6				1/4	6.4	12.0	21.5	12.1			

型号 Item NO	导线截面mm ² Cable Size A.W.G	材料厚度 Thickness (mm)	最大电流 Max Current	美制螺栓号 USA Screw	螺栓口直径 Screw Dia. d2(mm)	尺寸 Dimension(mm)					
						W	L	F	E	Dφ	dφ
SNB 5.5-3.5	4-6 (12-10)	1.0	48A	#6	3.7	7.2	18.2	7.5	6.8	5.6	3.4
SNB 5.5-4 S				#8	4.3	8.3	19.5	7.5			
SNB 5.5-4 L				#8	4.3	9.0	19.5	7.5			
SNB 5.5-5				#10	5.3	9.0	19.5	7.5			
SNB 5.5-6 S				1/4	6.4	9.0	19.5	7.5			
SNB 5.5-6 L				1/4	6.4	12.0	25.5	12.0			
SNB 5.5-8				5/16	8.4	14.0	24.5	11.5			

PVC绝缘护套叉形端子

(适用于软线)

Vinyl-Insulated Ring Terminal

(Apply in flexible wire)

材质: 紫铜 Terminal Body: Copper

护套: PVC Insulation: Vinyl

表面处理: 镀锡 Plating: Tin

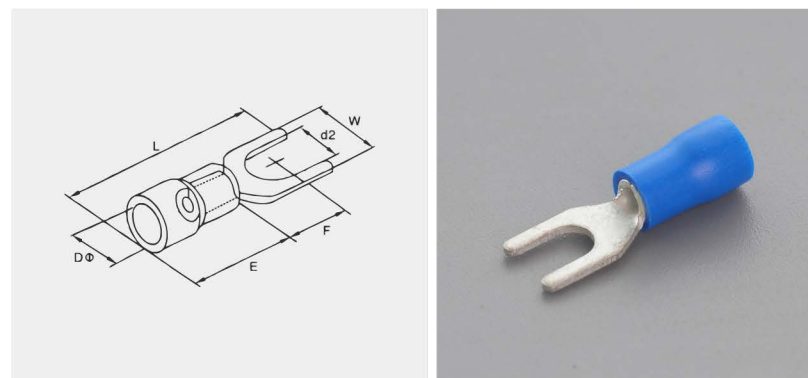

型号 Item NO	导线截面mm ² Cable Size A.W.G	材料厚度 Thickness (mm)	最大电流 Max Current	美制螺栓号 USA Screw	螺栓口直径 Screw Dia. d2(mm)	尺寸 Dimension(mm)					颜色 Color
						W	L	F	E	Dφ	
SV 0.5-3	0.2-0.75 (24-18)	0.5	10A	#4	3.2	5.7	19.9	5.1	10.0	2.7	黄
SV 0.5-4				#8	4.3	6.4	19.9	5.3			Yellow

型号 Item NO	导线截面mm ² Cable Size A.W.G	材料厚度 Thickness (mm)	最大电流 Max Current	美制螺栓号 USA Screw	螺栓口直径 Screw Dia. d2(mm)	尺寸 Dimension(mm)					颜色 Color
						W	L	F	E	Dφ	
SV 1.25-3	0.5-1.5 (22-16)	0.75	19A	#4	3.2	5.7	21.8	6.5	10.7	4.2	红
SV 1.25-3.5 S				#6	3.7	5.7	21.8	6.5			
SV 1.25-3.5 L				#6	3.7	6.4	21.8	6.5			
SV 1.25-4 S				#8	4.3	6.4	21.8	6.5			
SV1.25-4 M				#8	4.3	7.2	21.8	6.5			
SV 1.25-4 L				#8	4.3	8.1	21.8	6.5			
SV 1.25-5 S				#10	5.3	8.1	21.8	6.5			
SV 1.25-5 L				#10	5.3	9.5	21.8	6.5			
SV 1.25-6 S				1/4	6.4	9.5	21.8	6.5			
SV 1.25-6 L	1/4	6.4	12.0	28.0	11.0						

型号 Item NO	导线截面mm ² Cable Size A.W.G	材料厚度 Thickness (mm)	最大电流 Max Current	美制螺栓号 USA Screw	螺栓口直径 Screw Dia. d2(mm)	尺寸 Dimension(mm)					颜色 Color
						W	L	F	E	Dφ	
SV 2-3	1.5-25 (16-14)	0.8	27A	#4	3.2	5.7	21.7	6.5	10.7	4.9	蓝
SV 2-3.5 S				#6	3.7	5.7	21.7	6.5			
SV 2-3.5 L				#6	3.7	6.2	21.7	6.5			
SV 2-4 S				#8	4.3	6.4	21.7	6.5			
SV 2-4 M				#8	4.3	7.2	21.7	6.5			
SV 2-4 L				#8	4.3	8.1	21.7	6.5			
SV 2-5 S				#10	5.3	8.1	21.7	6.5			
SV 2-5 L				#10	5.3	9.5	21.7	6.5			
SV 2-6 S				1/4	6.4	9.5	21.7	6.5			
SV 2-6 L	1/4	6.4	12.0	27.7	11.0						

PVC绝缘护套叉形端子

(适用于软线)

Vinyl-Insulated Ring Terminal

(Apply in flexible wire)

材质: 紫铜 Terminal Body: Copper

护套: PVC Insulation: Vinyl

表面处理: 镀锡 Plating: Tin

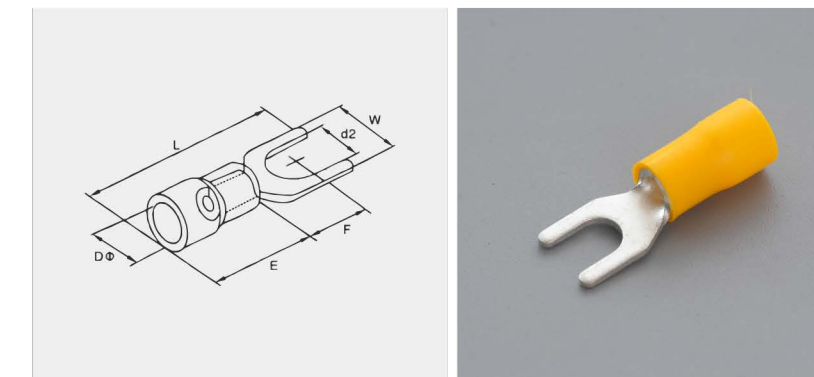

型号 Item NO	导线截面mm ² Cable Size A.W.G	材料厚度 Thickness (mm)	最大电流 Max Current	美制螺栓号 USA Screw	螺栓口直径 Screw Dia. d2(mm)	尺寸 Dimension(mm)					颜色 Color
						W	L	F	E	Dφ	
SV 3.5-3	2.5-4 (14-12)	1.0	37A	#4	3.2	5.7	25.8	7.0	6.0	5.0	黑
SV 3.5-4 S				#8	4.3	7.2	25.8	7.0			
SV 3.5-4				#8	4.3	7.2	25.8	7.0			
SV 3.5-5				#10	5.3	8.0	25.8	7.0			
SV 3.5-6				1/4	6.4	12.0	25.8	12.1			

型号 Item NO	导线截面mm ² Cable Size A.W.G	材料厚度 Thickness (mm)	最大电流 Max Current	美制螺栓号 USA Screw	螺栓口直径 Screw Dia. d2(mm)	尺寸 Dimension(mm)					颜色 Color
						W	L	F	E	Dφ	
SV 5.5-3.5	4-6 (12-10)	1.0	48A	#6	3.7	7.2	24.8	7.5	14	6.6	黄
SV 5.5-4 S				#8	4.3	8.3	26.0	7.5			
SV 5.5-4 L				#8	4.3	9.0	26.0	7.5			
SV 5.5-5				#10	5.3	9.0	26.0	7.5			
SV 5.5-6 S				1/4	6.4	9.0	26.0	7.5			
SV 5.5-6 L				1/4	6.4	12.0	32.0	12.0			
SV 5.5-8				5/16	8.4	14.0	30.8	11.5			

尼龙绝缘护套叉形端子

(适用于软线)

Nylon-Insulated Spade Terminal

(Apply in flexible wire)

材质: 紫铜 Terminal Body: Copper
 护套: 尼龙 Insulation: Nylon
 温度: 105°C Temperature: 105°C
 表面处理: 镀锡 Plating: Tin

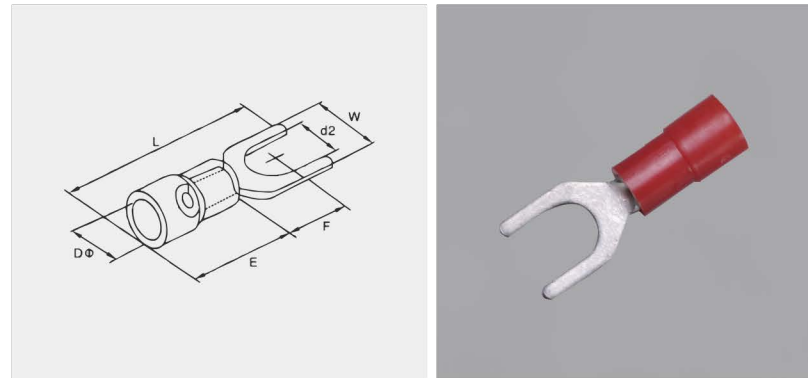

型号 Item NO	导线截面mm ² Cable Size A.W.G	材料厚度 Thickness (mm)	最大电流 Max Current	美制螺栓号 USA Screw	螺栓口直径 Screw Dia. d2(mm)	尺寸 Dimension(mm)					颜色 Color
						W	L	F	E	Dφ	
SVN 1.25-3	0.5-1.5 (22-16)	0.75	19A	#4	3.2	5.7	22.0	6.5	11.0	4.3	红 Red
SVN 1.25-3.5 S				#6	3.7	5.7	22.0	6.5			
SVN 1.25-3.5 L				#6	3.7	6.4	22.0	6.5			
SVN 1.25-4 S				#8	4.3	6.4	22.0	6.5			
SVN 1.25-4 M				#8	4.3	7.2	22.0	6.5			
SVN 1.25-4 L				#8	4.3	8.1	22.0	6.5			
SVN 1.25-5 S				#10	5.3	8.1	22.0	6.5			
SVN 1.25-5 L				#10	5.3	9.5	22.0	6.5			
SVN 1.25-6 S				1/4	6.4	9.5	22.0	6.5			
SVN 1.25-6 L				1/4	6.4	12.0	28.0	11.0			

型号 Item NO	导线截面mm ² Cable Size A.W.G	材料厚度 Thickness (mm)	最大电流 Max Current	美制螺栓号 USA Screw	螺栓口直径 Screw Dia. d2(mm)	尺寸 Dimension(mm)					颜色 Color
						W	L	F	E	Dφ	
SVN 2-3	0.5-1.5 (22-16)	0.8	27A	#4	3.2	5.7	22.0	6.5	11.0	4.9	蓝 Blue
SVN 2-3.5 S				#6	3.7	5.7	22.0	6.5			
SVN 2-3.5 L				#6	3.7	6.2	22.0	6.5			
SVN 2-4 S				#8	4.3	6.4	22.0	6.5			
SVN 2-4 M				#8	4.3	7.2	22.0	6.5			
SVN 2-4 L				#8	4.3	8.1	22.0	6.5			
SVN 2-5 S				#10	5.3	8.1	22.0	6.5			
SVN 2-5 L				#10	5.3	9.5	22.0	6.5			
SVN 2-6 S				1/4	6.4	9.5	22.0	6.5			
SVN 2-6 L				1/4	6.4	12.0	28.0	11.0			

尼龙绝缘护套叉形端子

(适用于软线)

Nylon-Insulated Spade Terminal

(Apply in flexible wire)

材质: 紫铜 Terminal Body: Copper
 护套: 尼龙 Insulation: Nylon
 温度: 105°C Temperature: 105°C
 表面处理: 镀锡 Plating: Tin

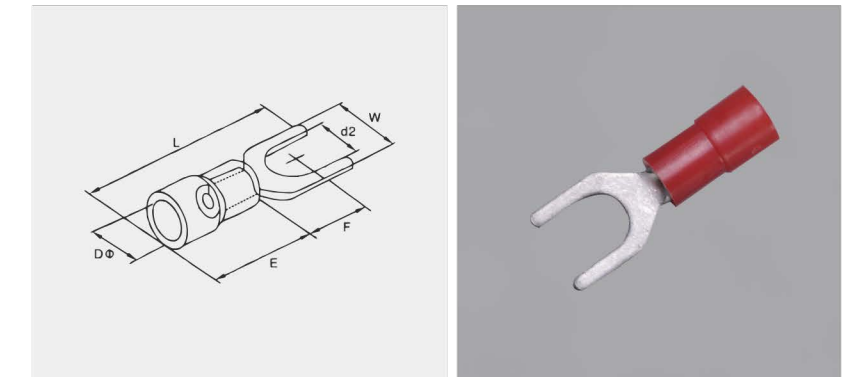

型号 Item NO	导线截面mm ² Cable Size A.W.G	材料厚度 Thickness (mm)	最大电流 Max Current	美制螺栓号 USA Screw	螺栓口直径 Screw Dia. d2(mm)	尺寸 Dimension(mm)					颜色 Color
						W	L	F	E	Dφ	
SVN 3.5-3	2.5-4 (14-12)	1.0	37A	#4	3.2	5.7	25.2	7.0	13.3	6.0	黑 Black
SVN 3.5-4 S				#8	4.3	7.2	25.2	7.0			
SVN 3.5-4				#8	4.3	7.2	25.2	7.0			
SVN 3.5-5				#10	5.3	8.0	25.2	7.0			
SVN 3.5-5				#10	5.3	8.0	25.2	7.0			
SVN 3.5-6				1/4	6.4	12.0	28.7	12.1			

型号 Item NO	导线截面mm ² Cable Size A.W.G	材料厚度 Thickness (mm)	最大电流 Max Current	美制螺栓号 USA Screw	螺栓口直径 Screw Dia. d2(mm)	尺寸 Dimension(mm)					颜色 Color
						W	L	F	E	Dφ	
SVN 5.5-3.5	4-6 (12-10)	1.0	48A	#6	3.7	7.2	24.8	7.5	14.0	6.6	黄 Yellow
SVN 5.5-4 S				#8	4.3	8.3	26.5	7.5			
SVN 5.5-4 L				#8	4.3	9.0	26.5	7.5			
SVN 5.5-5				#10	5.3	9.0	26.5	7.5			
SVN 5.5-6 S				1/4	6.4	9.0	26.5	7.5			
SVN 5.5-6 L				1/4	6.4	12.0	32.0	12.0			
SVN 5.5-8	5/16	8.4	14.0	30.7	11.5						

尼龙绝缘护套叉形端子

(加铜套)(适用于软线)

Nylon-Insulated Spade Terminal

(Double Copper Sleeve) (Apply in flexible wire)

材质: 紫铜 Terminal Body: Copper
 护套: 尼龙 Insulation: Nylon
 温度: 105°C Temperature: 105°C
 表面处理: 镀锡 Plating: Tin

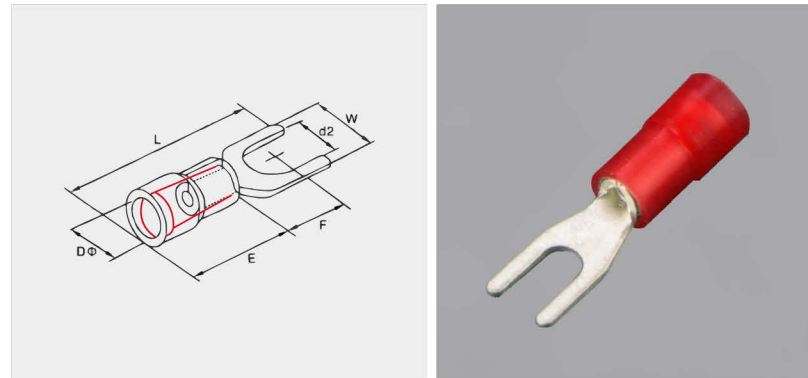

型号 Item NO	导线截面mm ² Cable Size A.W.G	材料厚度 Thickness (mm)	最大电流 Max Current	美制螺栓号 USA Screw	螺栓口直径 Screw Dia. d2(mm)	尺寸 Dimension(mm)					颜色 Color
						w	L	F	E	Dφ	
SVN 1.25-3 D	0.5-1.5 (22-16)	0.75	19A	#4	3.2	5.7	22.0	6.5	11.0	3.8	红 Red
SVN 1.25-3.5 S D				#6	3.7	5.7	22.0	6.5			
SVN 1.25-3.5 L D				#6	3.7	6.4	22.0	6.5			
SVN 1.25-4 S D				#8	4.3	6.4	22.0	6.5			
SVN 1.25-4 M D				#8	4.3	7.2	22.0	6.5			
SVN 1.25-4 L D				#8	4.3	8.1	22.0	6.5			
SVN 1.25-5 S D				#10	5.3	8.1	22.0	6.5			
SVN 1.25-5 L D				#10	5.3	9.5	22.0	6.5			
SVN 1.25-6 S D				1/4	6.4	9.5	22.0	6.5			
SVN 1.25-6 L D				1/4	6.4	12.0	28.0	11.0			

型号 Item NO	导线截面mm ² Cable Size A.W.G	材料厚度 Thickness (mm)	最大电流 Max Current	美制螺栓号 USA Screw	螺栓口直径 Screw Dia. d2(mm)	尺寸 Dimension(mm)					颜色 Color
						w	L	F	E	Dφ	
SVN 2-3 D	0.5-1.5 (22-16)	0.8	27A	#4	3.2	5.7	22.0	6.5	110	4.4	蓝 Blue
SVN 2-3.5 S D				#6	3.7	5.7	22.0	6.5			
SVN 2-3.5 L D				#6	3.7	6.2	22.0	6.5			
SVN 2-4 S D				#8	4.3	6.4	22.0	6.5			
SVN 2-4 M D				#8	4.3	7.2	22.0	6.5			
SVN 2-4 L D				#8	4.3	8.1	22.0	6.5			
SVN 2-5 S D				#10	5.3	8.1	22.0	6.5			
SVN 2-5 L D				#10	5.3	9.5	22.0	6.5			
SVN 2-6 S D				1/4	6.4	9.5	22.0	6.5			
SVN 2-6 L D				1/4	6.4	12.0	28.0	11.0			

尼龙绝缘护套叉形端子

(加铜套)(适用于软线)

Nylon-Insulated Spade Terminal

(Double Copper Sleeve) (Apply in flexible wire)

材质: 紫铜 Terminal Body: Copper
 护套: 尼龙 Insulation: Nylon
 温度: 105°C Temperature: 105°C
 表面处理: 镀锡 Plating: Tin

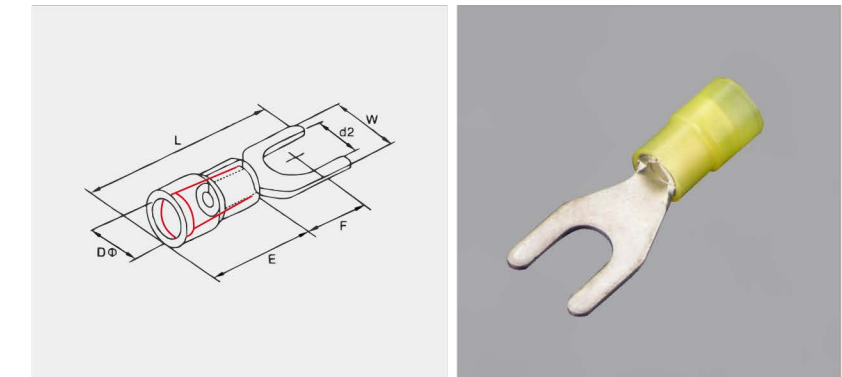

型号 Item NO	导线截面mm ² Cable Size A.W.G	材料厚度 Thickness (mm)	最大电流 Max Current	美制螺栓号 USA Screw	螺栓口直径 Screw Dia. d2(mm)	尺寸 Dimension(mm)					颜色 Color
						w	L	F	E	Dφ	
SVN 3.5-3 D	2.5-4 (14-12)	1.0	37A	#4	3.2	5.7	25.2	7.0	13.3	5.4	黑 Black
SVN 3.5-4 S D				#8	4.3	7.2	25.2	7.0			
SVN 3.5-4 L D				#8	4.3	7.2	25.2	7.0			
SVN 3.5-5 D				#10	5.3	8.0	25.2	7.0			
SVN 3.5-5 L D				1/4	6.4	12.0	28.2	12.1			
SVN 3.5-6 D				1/4	6.4	12.0	28.2	12.1			

型号 Item NO	导线截面mm ² Cable Size A.W.G	材料厚度 Thickness (mm)	最大电流 Max Current	美制螺栓号 USA Screw	螺栓口直径 Screw Dia. d2(mm)	尺寸 Dimension(mm)					颜色 Color
						w	L	F	E	Dφ	
SVN 5.5-3.5 D	4-6 (12-10)	1.0	48A	#6	3.7	7.2	24.8	7.5	14.0	6.1	黄 Yellow
SVN 5.5-4 S D				#8	4.3	8.3	26.5	7.5			
SVN 5.5-4 L D				#8	4.3	9.0	26.5	7.5			
SVN 5.5-5 D				#10	5.3	9.0	26.5	7.5			
SVN 5.5-6 S D				1/4	6.4	9.0	26.5	7.5			
SVN 5.5-6 L D				1/4	6.4	12.0	32.0	12.0			
SVN 5.5-8 D				5/16	8.4	14.0	30.7	11.5			

无绝缘护套片形端子

(适用于软线)

Non-Insulated Blade Terminal

(Apply in flexible wire)

材质: 紫铜 Terminal Body: Copper
表面处理: 镀锡 Plating: Tin

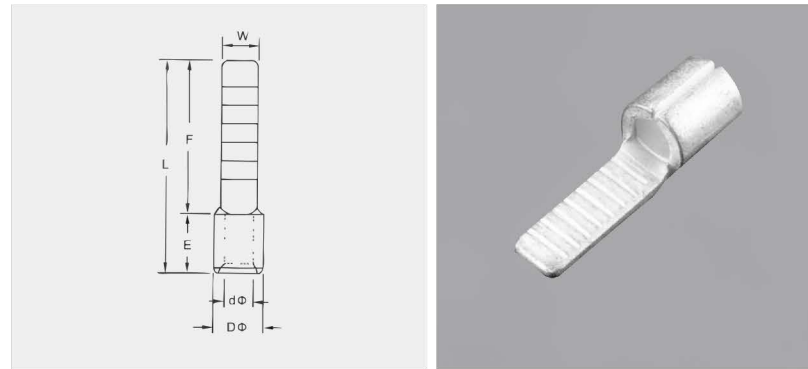

型号 Item NO	导线截面mm ² Cable Size A.W.G	材料厚度 Thickness (mm)	最大电流 Max Current	尺寸 Dimension(mm)					
				W	L	F	E	Dφ	dφ
DBN 1.25-10	0.5-1.5 (22-16)	0.75	19A	2.3	14.8	10.0	4.8	3.4	1.7
DBN 1.25-14				2.3	18.8	14.0			
DBN 1.25-18				2.2	22.8	18.0			
DBN 2-10	1.5-2.5 (16-14)	0.8	27A	2.8	14.8	10.0	4.8	4.1	2.3
DBN 2-14				2.4	18.9	14.1			
DBN 2-18				2.2	22.8	18.0			
DBN 5.5-10	4-6 (12-10)	0.75	48A	2.8	16.0	10.0	6.0	5.6	3.4
DBN 5.5-14				4.5	21.0	14.0			
DBN 5.5-18				4.5	23.0	18.0			
DBN 8-14	6-10 (8)	1.2	62A	5.0	22.5	14.0	8.5	7.2	4.8
DBN 14-16	10-16 (8)	1.4	88A	6.0	30.6	16.0	14.0	9.0	6.2

PVC绝缘护套片形端子

(适用于软线)

Vinyl-Insulated Blade Terminal

(Apply in flexible wire)

材质: 紫铜 Terminal Body: Copper
护套: PVC Insulation: Vinyl
表面处理: 镀锡 Plating: Tin

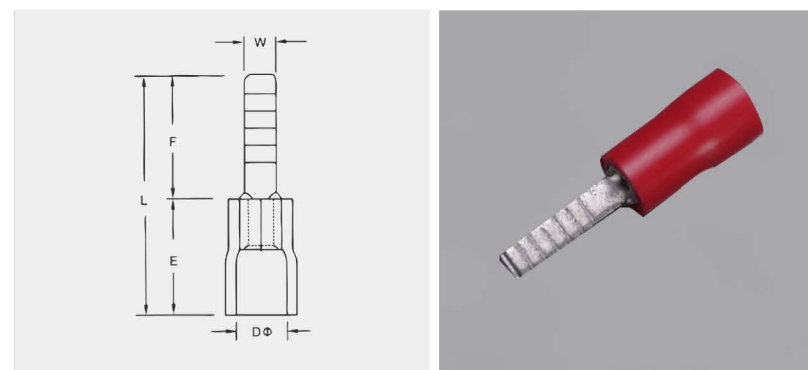

型号 Item NO	导线截面mm ² Cable Size A.W.G	材料厚度 Thickness (mm)	最大电流 Max Current	尺寸 Dimension(mm)					颜色 Color
				W	L	F	E	Dφ	
DBV 1.25-10	0.5-1.5 (22-16)	0.75	19A	2.3	20.7	10.0	10.7	4.2	红 red
DBV 1.25-14				2.3	24.7	14.0			
DBV 1.25-18				2.2	28.7	18.0			
DBV 2-10	1.5-2.5 (16-14)	0.8	27A	2.8	19.7	9.0	10.7	4.9	蓝 blue
DBV 2-14				2.4	24.7	14.0			
DBV 2-18				2.2	28.7	18.0			
DBV 5.5-10	4-6 (12-10)	1.0	48A	2.8	24.0	10.0	14.0	6.5	黄 yellow
DBV 5.5-14				4.5	28.0	14.0			
DBV 5.5-18				4.5	32.0	18.0			
DBV 8-14	6-10 (8)	1.2	62A	5.0	31.0	14.0	17.0	8.2	红 red
DBV 14-16	10-16 (8)	1.4	88A	6.0	36.5	16.0	20.5	10.2	蓝 blue

尼龙绝缘护套片形端子

(适用于软线)

Nylon-Insulated Blade Terminal

(Apply in flexible wire)

材质: 紫铜 Terminal Body: Copper
护套: 尼龙 Insulation: Nylon
温度: 105°C Temperature: 105°C
表面处理: 镀锡 Plating: Tin

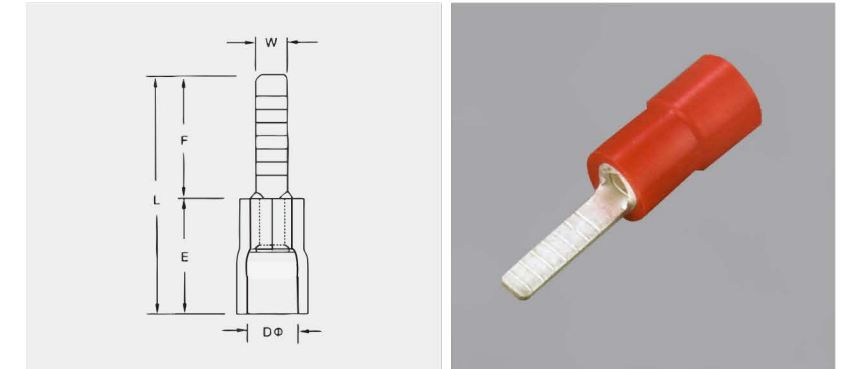

型号 Item NO	导线截面mm ² Cable Size A.W.G	材料厚度 Thickness (mm)	最大电流 Max Current	尺寸 Dimension(mm)					颜色 Color
				w	L	F	E	Dφ	
DBVN 1.25-10	0.5-1.5 (22-16)	0.75	19A	2.3	21.0	10.0	11.0	4.3	红 red
DBVN 1.25-14				2.3	25.0	14.0			
DBVN 1.25-18				2.2	29.0	18.0			
DBVN 2-10	1.5-2.5 (16-14)	0.8	27A	2.8	21.0	10.0	11.0	4.9	蓝 blue
DBVN 2-14				2.4	25.0	14.0			
DBVN 2-18				2.2	29.0	18.0			
DBVN 5.5-10	4-6 (12-10)	1.0	48A	2.8	24.0	10.0	14.0	5.6	黄 yellow
DBVN 5.5-14				4.5	28.0	14.0			
DBVN 5.5-18				4.5	32.0	18.0			

尼龙绝缘护套片形端子

(加铜套)(适用于软线)

Nylon-Insulated Blade Terminal

(Double Copper Sleeve) (Apply in flexible wire)

材质: 紫铜 Terminal Body: Copper
护套: 尼龙 Insulation: Nylon
温度: 105°C Temperature: 105°C
表面处理: 镀锡 Plating: Tin

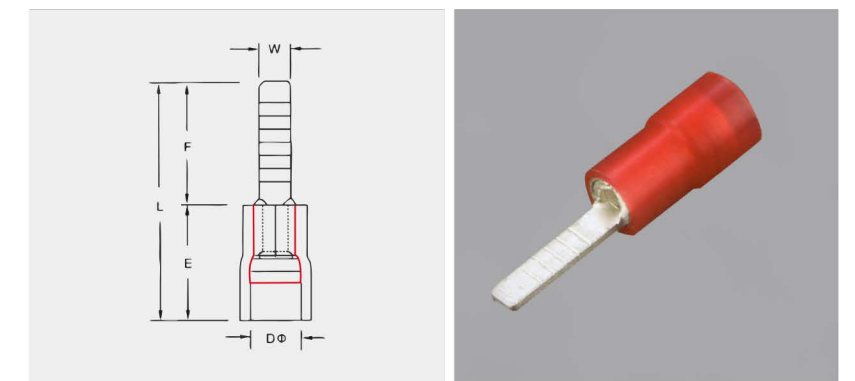

型号 Item NO	导线截面mm ² Cable Size A.W.G	材料厚度 Thickness (mm)	最大电流 Max Current	尺寸 Dimension(mm)					颜色 Color
				w	L	F	E	Dφ	
DBVN 1.25-10 D	0.5-1.5 (22-16)	0.75	19A	2.3	21.0	10.0	11.0	3.8	红 red
DBVN 1.25-14 D				2.3	25.0	14.0			
DBVN 1.25-18 D				2.2	29.0	18.0			
DBVN 2-10 D	1.5-2.5 (16-14)	0.8	27A	2.8	21.0	10.0	11.0	4.4	蓝 blue
DBVN 2-14 D				2.4	25.0	14.0			
DBVN 2-18 D				2.2	29.0	18.0			
DBVN 5.5-10 D	4-6 (12-10)	1.0	48A	2.8	24.0	10.0	14.0	6.1	黄 yellow
DBVN 5.5-14 D				4.5	28.0	14.0			
DBVN 5.5-18 D				4.5	32.0	18.0			

无绝缘护套针形端子

(适用于软线)

Non-Insulated Pin Terminal

(Apply in flexible wire)

材质: 紫铜 Terminal Body: Copper

表面处理: 镀锡 Plating: Tin

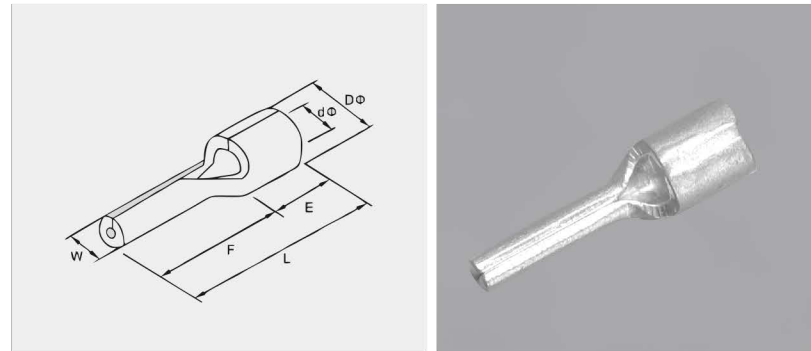

型号 Item NO	导线截面mm ² Cable Size A.W.G	材料厚度 Thickness (mm)	最大电流 Max Current	尺寸 Dimension(mm)					
				W	L	E	F	Dφ	dφ
PTN 1.25-10	0.5~1.5 (22~16)	0.75	19A	1.9	14.8	4.8	10.0	3.4	1.7
PTN 1.25-12				1.9	16.8	4.8	12.0		
PTN 1.25-13				1.9	17.8	4.8	13.0		
PTN 1.25-18				1.9	22.8	4.8	18.0		
PTN 2-10	1.5~2.5 (16~14)	0.8	27A	1.9	14.8	4.8	10.0	4.1	2.3
PTN 2-12				1.9	16.8	4.8	12.0		
PTN 2-13				1.9	17.8	4.8	13.0		
PTN 2-18				1.9	22.8	4.8	18.0		
PTN 3.5-10	2.5~4 (14~12)	1.0	37A	2.8	14.8	6.0	10.0	5.0	3.0
PTN 3.5-13				2.8	19.8	6.0	13.0		
PTN 5.5-13	4~6(12~10)	1.0	48A	2.8	19.3	6.0	13.3	5.6	3.4

尼龙绝缘护套针形端子

(适用于软线)

Nylon-Insulated Pin Terminal

(Apply in flexible wire)

材质: 紫铜 Terminal Body: Copper

护套: 尼龙 Insulation: Nylon

温度: 105°C Temperature: 105°C

表面处理: 镀锡 Plating: Tin

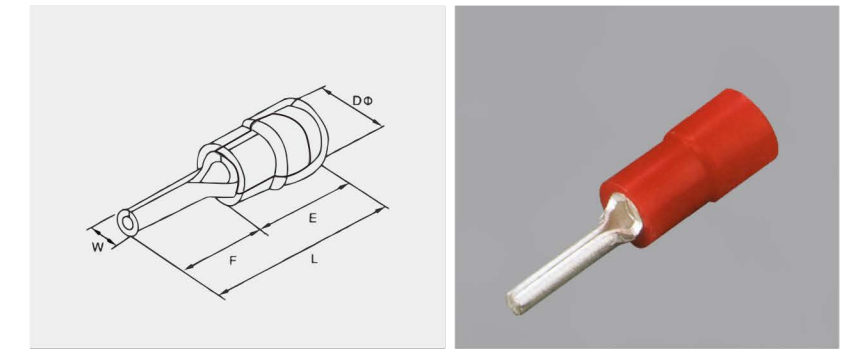

型号 Item NO	导线截面mm ² Cable Size A.W.G	材料厚度 Thickness (mm)	最大电流 Max Current	尺寸 Dimension(mm)					颜色 Color
				W	L	E	F	Dφ	
PTVN 1.25-10	0.5~1.5 (22~16)	0.75	19A	1.9	21.0	11.0	10.0	4.3	红 red
PTVN 1.25-12				1.9	23.0	11.0	12.0		
PTVN 1.25-13				1.9	24.0	11.0	13.0		
PTVN 1.25-18				1.9	29.0	11.0	18.0		
PTVN 2-10	1.5~2.5 (16~14)	0.8	27A	1.9	21.0	11.0	10.0	4.9	蓝 blue
PTVN 2-12				1.9	23.0	11.0	12.0		
PTVN 2-13				1.9	24.0	11.0	13.0		
PTVN 2-18				1.9	29.0	11.0	18.0		
PTVN 3.5-10	2.5~4 (14~12)	1.0	37A	2.8	23.8	13.3	10.0	6.0	黑 Black
PTVN 3.5-13				2.8	26.3	13.3	13.0		
PTVN 5.5-13	4~6(12~10)	1.0	48A	2.8	27.0	14.0	13.0	6.6	黄 yellow

PVC绝缘护套针形端子

(适用于软线)

Vinyl-Insulated Pin Terminal

(Apply in flexible wire)

材质: 紫铜 Terminal Body: Copper

护套: PVC Insulation: Vinyl

表面处理: 镀锡 Plating: Tin

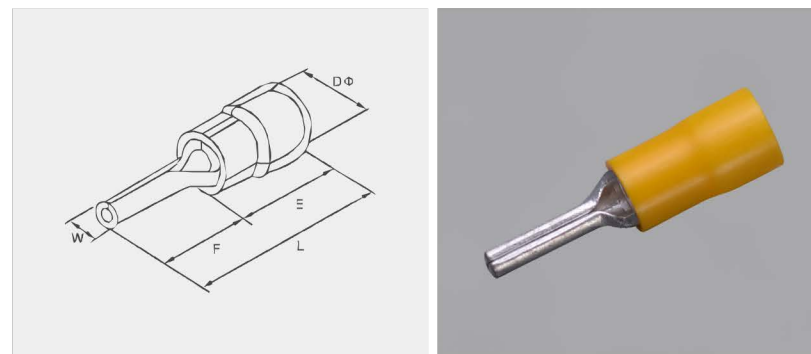

型号 Item NO	导线截面mm ² Cable Size A.W.G	材料厚度 Thickness (mm)	最大电流 Max Current	尺寸 Dimension(mm)					颜色 Color
				W	L	E	F	Dφ	
PTV 1.25-10	0.5~1.5 (22~16)	0.75	19A	1.9	20.7	10.7	10.0	4.2	红 red
PTV 1.25-12				1.9	22.7	10.7	12.0		
PTV 1.25-13				1.9	23.7	10.7	13.0		
PTV 1.25-18				1.9	28.7	10.7	18.0		
PTV 2-10	1.5~2.5 (16~14)	0.8	27A	1.9	20.7	10.7	10.0	4.9	蓝 blue
PTV 2-12				1.9	22.7	10.7	12.0		
PTVN 2-13				1.9	23.7	10.7	13.0		
PTV 2-18				1.9	28.7	10.7	18.0		
PTV 3.5-10	2.5~4 (14~12)	1.0	36A	2.8	23.8	13.8	10.0	5.8	黑 Black
PTV 3.5-13				2.8	26.3	13.8	13.0		
PTV 5.5-13	4~6(12~10)	1.0	48A	2.6	27.0	14.0	13.0	6.5	黄 yellow

尼龙绝缘护套针形端子

(加铜套)(适用于软线)

Nylon-Insulated Pin Terminal

(Double Copper Sleeve) (Apply in flexible wire)

材质: 紫铜 Terminal Body: Copper

护套: 尼龙 Insulation: Nylon

温度: 105°C Temperature: 105°C

表面处理: 镀锡 Plating: Tin

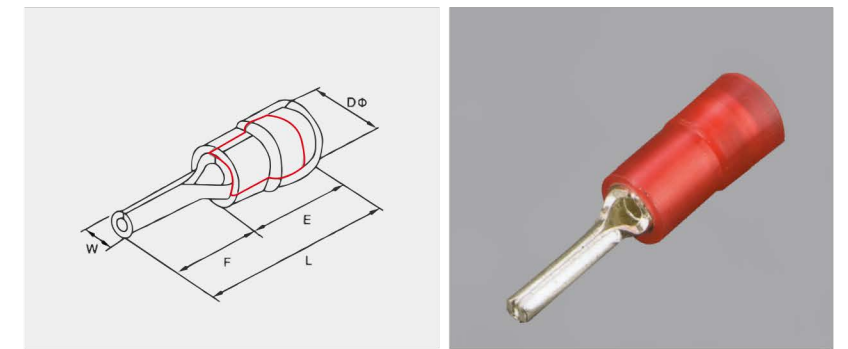

型号 Item NO	导线截面mm ² Cable Size A.W.G	材料厚度 Thickness (mm)	最大电流 Max Current	尺寸 Dimension(mm)					颜色 Color
				W	L	E	F	Dφ	
PTVN 1.25-10 D	0.5~1.5 (22~16)	0.75	19A	1.9	21.0	11.0	10.0	3.8	红 red
PTVN 1.25-12 D				1.9	23.0	11.0	12.0		
PTVN 1.25-13 D				1.9	24.0	11.0	13.0		
PTVN 1.25-18 D				1.9	29.0	11.0	18.0		
PTVN 2-10 D	1.5~2.5 (16~14)	0.8	27A	1.9	21.0	11.0	10.0	4.4	蓝 blue
PTVN 2-12 D				1.9	23.0	11.0	12.0		
PTVN 2-13 D				1.9	24.0	11.0	13.0		
PTVN 2-18 D				1.9	29.0	11.0	18.0		
PTVN 3.5-10 D	2.5~4 (14~12)	1.0	36A	2.8	23.8	13.3	10.0	5.4	黑 Black
PTVN 3.5-13 D				2.8	26.3	13.3	13.0		
PTVN 5.5-13 D	4~6(12~10)	1.0	48A	2.8	27.0	14.0	13.0	6.1	黄 yellow

无绝缘护套针形端子

(适用于软线)

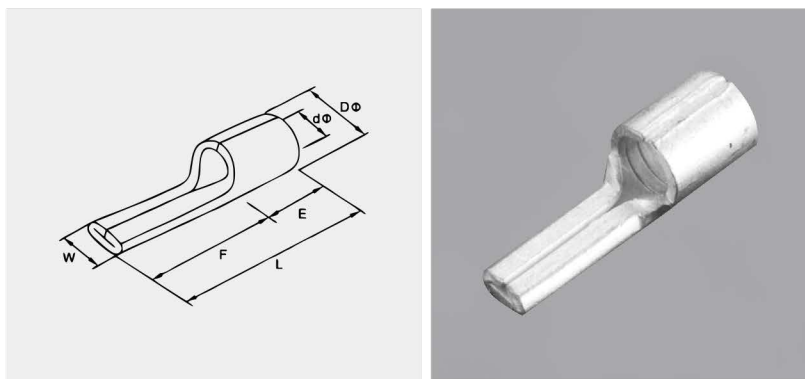
Non-Insulated Pin Terminal
(Apply in flexible wire)材质: 紫铜 Terminal Body: Copper
表面处理: 镀锡 Plating: Tin

型号 Item NO	导线截面mm ² Cable Size A.W.G	材料厚度 Thickness (mm)	最大电流 Max Current	尺寸 Dimension(mm)					
				W	L	E	F	Dφ	dφ
PTNB 10-12	6.0-10(8)	1.1	62A	4.4	22.4	8.0	14.0	6.9	4.5
PTNB 16-13	10-16(6)	1.2	88A	5.5	26.0	10.0	16.0	8.4	5.8
PTNB 25-15	16-25(4)	1.2	115A	6.6	33.5	13.5	20.0	9.5	7.0
PTNB 35-20	35-50(2)	1.5	160A	8.0	40.5	16.0	24.5	11.8	8.4
PTNB 50-20	50-70(1/0)	1.8	215A	9.5	45.0	19.0	26.0	13.6	9.6
PTNB 70-25	70-95(2/0)	2.0	235A	11.0	55.0	24.0	31.0	15.8	11.4
PTNB 95-25	95-120(3/0)	2.5	255A	12.5	55.0	24.0	31.0	18.9	13.5

C45铜管片形端子

(适用于软线)

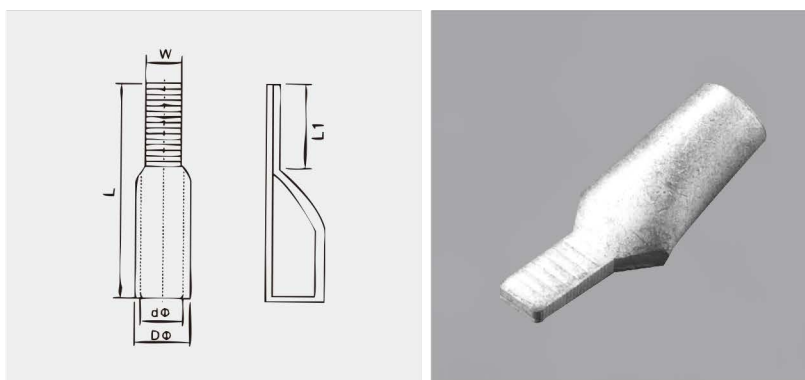
C45 Copper Blade Terminal
(Apply in flexible wire)材质: 紫铜 Terminal Body: Copper
表面处理: 镀锡 Plating: Tin

型号 Item NO	尺寸 Dimension(mm)				
	Dφ	dφ	L	L1	W
C-6	5.5	4.1	26.0	10.2	5.0
C-10	7.0	5.2	31.6	12.0	6.2
C-16	7.8	5.8	34.5	13.0	7.0
C-25	9.5	7.5	36.0	13.0	7.0
C-35	11.0	8.4	40.0	13.0	7.0
C-50	12.5	9.6	42.6	13.0	7.0
C-70	15.0	12.0	46.5	13.0	7.0
C-95	17.0	13.4	50.0	15.0	9.0

无绝缘护套短形中间平行端子

(适用于软线)

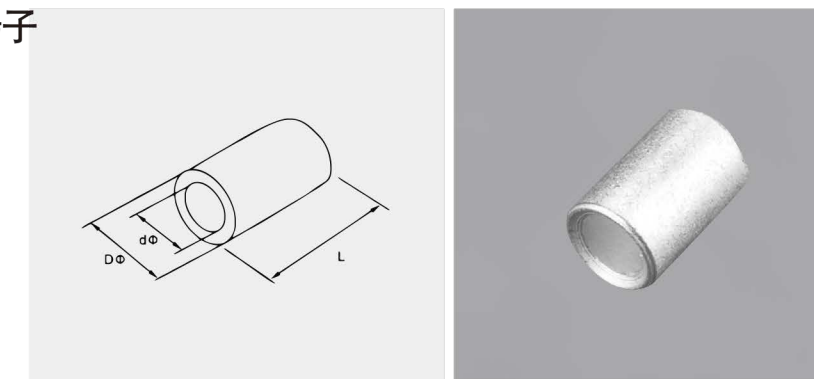
Non-Insulated Pin Terminal
(Apply in flexible wire)材质: 紫铜 Terminal Body: Copper
表面处理: 镀锡 Plating: Tin

型号 Item NO	导线截面Cable Size		最大电流 Max Current	尺寸 Dimension(mm)		
	A.W.G	mm ²		Dφ	dφ	L
PNT1.25	22-16	0.5-1.5	19A	3.3	2.0	8.0
PNT 2	16-14	1.5-2.5	27A	3.95	2.5	8.0
PNT5.5	12-10	4-6	48A	5.5	3.9	8.5
PNT8	#8	6-10	62A	7.0	4.8	9.5
PNT14	#6	10-16	88A	8.9	5.9	11.0
PNT22	#4	16-25	115A	11.3	7.8	13.5
PNT38	#2	35-50	160A	13.2	9.5	16.5
PNT60	1/0	50-70	215A	15.3	11.4	19.0
PNT70	2/0	70-95	235A	17.5	13.3	19.0
PNT80	3/0	95-120	255A	19.5	14.5	19.5
PNT100	4/0	120-150	300A	22.1	16.4	20.0
PNT150	(250/300)	150-185	395A	26.0	19.0	27.0
PNT180	(300/350)	185-240	440A	28.5	21.0	28.5
PNT200	(400/500)	240-300	470A	32.0	24.0	32.0
PNT325	(500/600)	300-400	650A	37.0	28.0	37.0

PVC全绝缘护套短形中间平行端子

Vinyl-Insulated parallel Terminal

材质: 紫铜 Terminal Body: Copper
 护套: PVC Insulation: Vinyl
 表面处理: 镀锡 Plating: Tin

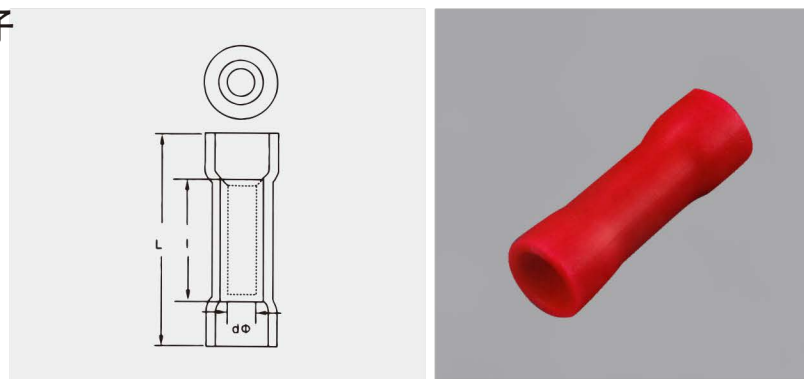

型号 Item NO	导线截面Cable Size		最大电流 Max Current	尺寸 Dimension(mm)			颜色 Color
	A.W.G	mm ²		l	d φ	L	
PVT 1.25	22-16	0.5-1.5	19A	8.0	2.0	16.0	红red
PVT 2	16-14	1.5-2.5	27A	8.0	2.5	16.0	蓝blue
PVT 5.5	12-10	4-6	48A	8.5	3.9	20.5	黄yellow

无绝缘护套中间平行端子

(适用于软线)

Non-Insulated Pin Terminal

(Apply in flexible wire)

材质: 紫铜 Terminal Body: Copper
 表面处理: 镀锡 Plating: Tin

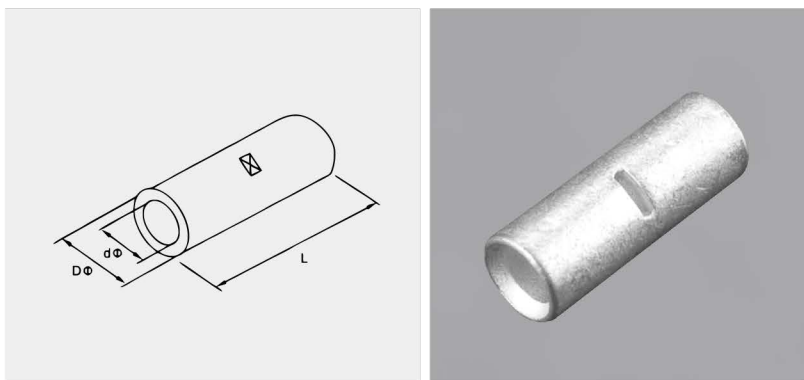

型号 Item NO	导线截面Cable Size		最大电流 Max Current	尺寸 Dimension(mm)		
	A.W.G	mm ²		D φ	d φ	L
BN 0.5	26-22	0.2-0.75	9A	2.1	1.4	10.0
BN 1.25	22-16	0.5-1.5	19A	3.3	2.0	15.0
BN 2	16-14	1.5-2.5	27A	3.95	2.5	15.0
BN 3.5	14-12	2.5-4	37A	5.0	3.3	15.0
BN 5.5	12-10	4-6	48A	5.5	3.9	15.0
BN 8	#8	6-10	62A	7.0	4.8	21.0
BN 14	#6	10-16	88A	8.9	5.9	27.0
BN 22	#4	16-25	115A	11.3	7.8	29.0
BN 38	#2	35-50	160A	13.2	9.5	32.0
BN 60	1/0	50-70	215A	15.3	11.4	36.0
BN 70	2/0	70-95	235A	17.5	13.3	37.0
BN 80	3/0	95-120	255A	19.5	14.5	38.0
BN 100	4/0	120-150	300A	22.1	16.4	38.0
BN 150	(250/300)	150-185	395A	26.0	19.0	54.0
BN 180	(300/350)	185-240	440A	28.5	21.0	57.0
BN 200	(400/500)	240-300	470A	32.0	24.0	63.0
BN 325	(500/600)	300-400	650A	37.0	28.0	72.0

PVC全绝缘护套中间平行端子

Vinyl-Insulated parallel Terminal

材质: 紫铜 Terminal Body: Copper
 护套: PVC Insulation: Vinyl
 表面处理: 镀锡 Plating: Tin

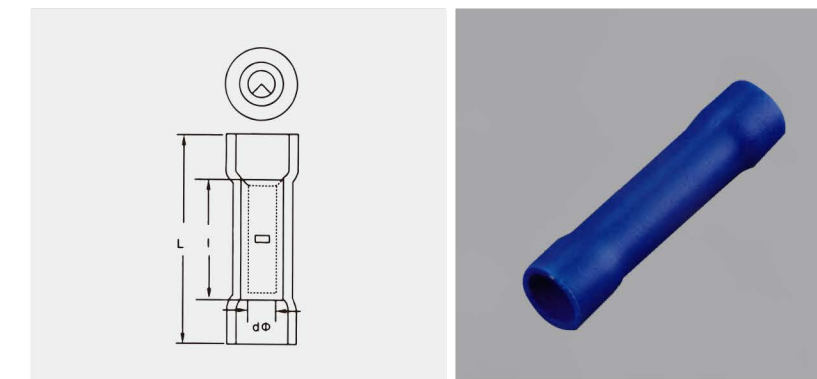

型号 Item NO	导线截面Cable Size		最大电流 Max Current	尺寸 Dimension(mm)			颜色 Color
	A.W.G	mm ²		l	d φ	L	
BV 1.25	22-16	0.5-1.5	19A	15.0	2.0	26.0	红red
BV 2	16-14	1.5-2.5	27A	15.0	2.5	26.0	蓝blue
BV 3.5	14-12	2.5-4	34A	15.0	3.3	26.0	黑black
BV 5.5	12-10	4-6	48A	15.0	3.9	26.0	黄yellow
BV 8	#8	6-10	62A	21.0	4.8	32.0	红red
BV 14	#6	10-16	88A	27.0	5.9	42.0	蓝blue
BV 22	#4	16-25	115A	29.0	7.8	50.0	黑black
BV 38	#2	35-50	160A	32.0	9.5	55.0	黄yellow

尼龙全绝缘护套短形中间平行端子

Nylon-Insulated butt splices Terminal

材质: 紫铜 Terminal Body: Copper
 护套: 尼龙 Insulation: Nylon
 温度: 105°C Temperature: 105°C
 表面处理: 镀锡 Plating: Tin

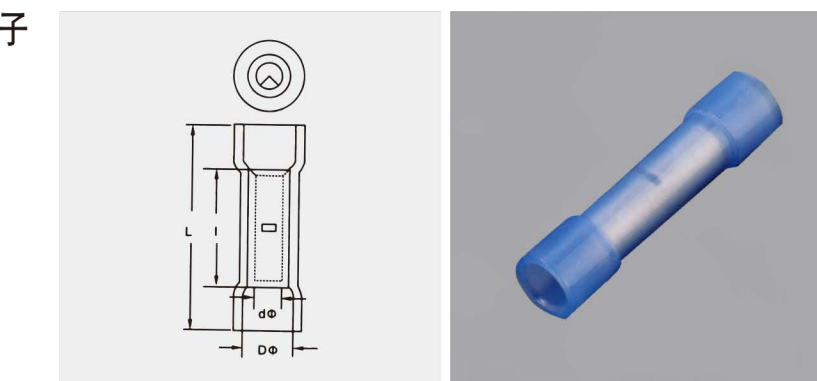

型号 Item NO	导线截面Cable Size		最大电流 Max Current	尺寸 Dimension(mm)				颜色 Color
	A.W.G	mm ²		l	D φ	d φ	L	
BNYF 0.5	26-22	0.2-0.75	9A	10.0	2.7	1.4	20.0	黄yellow
BNYF 1.25	22-16	0.5-1.5	19A	15.0	4.1	2.0	26.5	红red
BNYF 2	16-14	1.5-2.5	27A	15.0	4.4	2.5	26.5	蓝blue
BNYF 5.5	12-10	4-6	48A	15.0	6.6	3.9	27.0	黄yellow

热缩型防水全绝缘护套中间连接端子

Heat Shrink Insulated

材质: 紫铜 Terminal Body: Copper
 护套: 耐高温热缩管 Insulation: Heat Shrink Tube

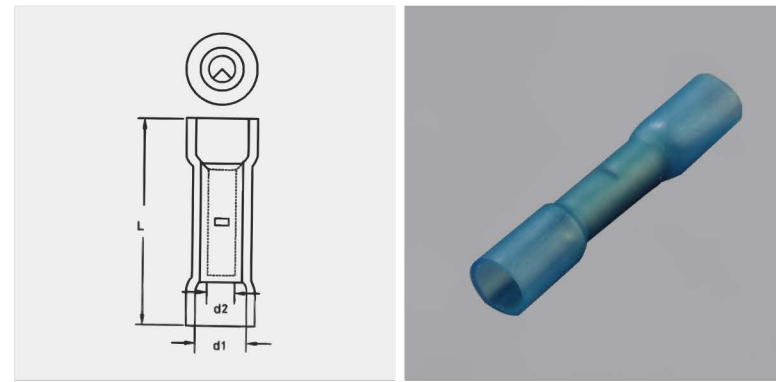

型号 Item NO	导线截面 Cable Size		最大电流 Max Current	尺寸 Dimension(mm)			颜色 Color
	A.W.G	mm ²		L	d1	d2	
BHT 0.5	26-22	0.2-0.75	9A	28.0	3.2	1.4	黄yellow
BHT 1.25	22-16	0.5-1.5	19A	38.0	4.8	1.7	红red
BHT 2	16-14	1.5-2.5	27A	38.0	5.8	2.4	蓝blue
BHT 5.5	12-10	4-6	48A	42.0	6.8	3.6	黄yellow

尼龙绝缘护套公插端子

(适用于软线)

Nylon-Insulating Male Terminal

(Apply in flexible wire)

材质: 黄铜 Terminal Body: Brass
 护套: 尼龙 Insulation: Nylon
 温度: 105°C Temperature: 105°C
 表面处理: 镀锡 Plating: Tin

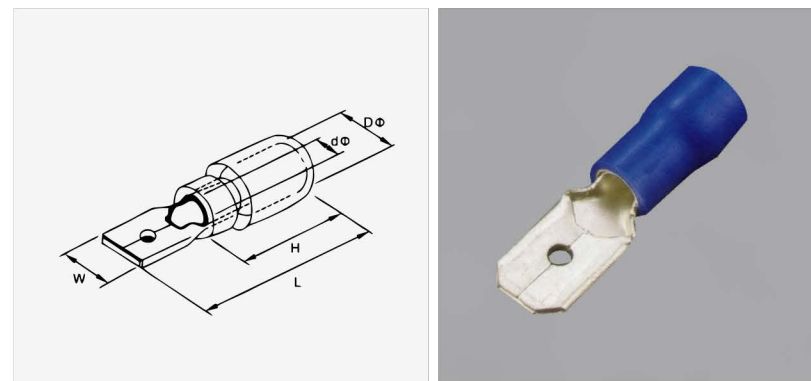

型号 Item NO	导线截面mm ² Cable Size A.W.G	最大电流 Max Current	接插规格 Connecting spec.	材料厚度 Thickness (mm)	尺寸 Dimension(mm)					颜色 Color
					W	Dφ	dφ	L	H	
MDD 1.25-110(5)	0.5-1.5 (22-16)	10A	0.5×2.8	0.5	2.8	4.0	1.7	17.7	10.0	红 red
MDD 1.25-110(8)			0.8×2.8	0.8	2.8	4.3	1.7	17.7		
MDD 1.25-187(5)			0.5×4.75	0.5	4.75	4.0	1.7	20.0		
MDD 1.25-187(8)			0.8×4.75	0.8	4.75	4.0	1.7	20.0		
MDD 1.25-250			0.8×6.35	0.4×2	6.35	4.1	1.7	21.0		

型号 Item NO	导线截面mm ² Cable Size A.W.G	最大电流 Max Current	接插规格 Connecting spec.	材料厚度 Thickness (mm)	尺寸 Dimension(mm)					颜色 Color
					W	Dφ	dφ	L	H	
MDD 2-187(5)	1.5-2.5 (16-14)	15A	0.5×4.75	0.5	4.75	4.0	2.3	20.0	10.0	蓝 blue
MDD 2-187(8)			0.8×4.75	0.8	4.75	4.7	2.3	20.0		
MDD 2-250			0.8×6.35	0.4×2	6.35	4.3	2.3	21.0		

型号 Item NO	导线截面mm ² Cable Size A.W.G	最大电流 Max Current	接插规格 Connecting spec.	材料厚度 Thickness (mm)	尺寸 Dimension(mm)					颜色 Color
					W	Dφ	dφ	L	H	
MDD 5.5-250	4-6 (12-10)	24A	0.8×6.35	0.4×2	6.35	5.7	3.4	25.0	13.0	黄 yellow

PVC绝缘护套母插端子

(适用于软线)

Vinyl-Insulated Spade Terminal

(Apply in flexible wire)

材质: 黄铜 Terminal Body: Brass
 护套: PVC Insulation: Vinyl
 温度: 105°C Temperature: 105°C
 表面处理: 镀锡 Plating: Tin

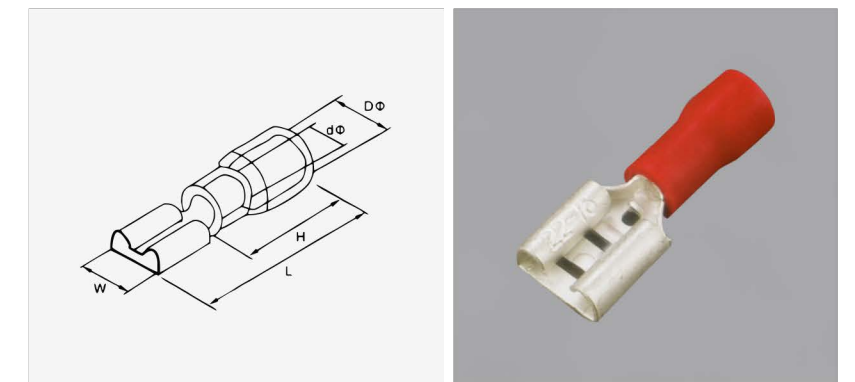

型号 Item NO	导线截面mm ² Cable Size A.W.G	最大电流 Max Current	接插规格 Connecting spec.	材料厚度 Thickness (mm)	尺寸 Dimension(mm)					颜色 Color
					W	Dφ	dφ	L	H	
FDD 1.25-110(5)	0.5-1.5 (22-16)	10A	0.5×2.8	0.3	3.8	3.8	1.7	19.2	10.0	红 red
FDD 1.25-110(8)			0.8×2.8		3.8	3.8	1.7	19.2		
FDD 1.25-187(5)			0.5×4.75	0.4	5.6	3.8	1.7	19.2		
FDD 1.25-187(8)			0.8×4.75		5.6	3.8	1.7	19.2		
FDD 1.25-205(5)			0.5×5.2		6.5	3.8	1.7	20.0		
FDD 1.25-205(8)			0.8×5.2		6.5	3.8	1.7	20.0		
FDD 1.25-250			0.8×6.35		7.6	3.8	1.7	20.0		

型号 Item NO	导线截面mm ² Cable Size A.W.G	最大电流 Max Current	接插规格 Connecting spec.	材料厚度 Thickness (mm)	尺寸 Dimension(mm)					颜色 Color
					W	Dφ	dφ	L	H	
FDD 2-110(5)	1.5-2.5 (16-14)	15A	0.5×2.8	0.3	3.8	4.3	2.3	19.2	10.5	蓝 blue
FDD 2-110(8)			0.8×2.8		3.8	4.3	2.3	19.2		
FDD 2-187(5)			0.5×4.75	0.4	5.6	4.3	2.3	19.2		
FDD 2-187(8)			0.8×4.75		5.6	4.3	2.3	19.2		
FDD 2-205(5)			0.5×5.2		6.5	4.3	2.3	19.4		
FDD 2-205(8)			0.8×5.2		6.5	4.3	2.3	19.4		
FDD 2-250			0.8×6.35		7.6	4.3	2.3	20.2		

型号 Item NO	导线截面mm ² Cable Size A.W.G	最大电流 Max Current	接插规格 Connecting spec.	材料厚度 Thickness (mm)	尺寸 Dimension(mm)					颜色 Color
					W	Dφ	dφ	L	H	
FDDN 5.5-250	4-6 (12-10)	24A	0.8×6.35	0.4	7.6	5.4	3.4	23.0	13.0	黄 yellow

尼龙绝缘护套母插端子

(适用于软线)

Nylon-Insulated Spade Terminal

(Apply in flexible wire)

材质: 黄铜 Terminal Body: Brass
 护套: 尼龙 Insulation: Nylon
 温度: 105℃ Temperature: 105℃
 表面处理: 镀锡 Plating: Tin

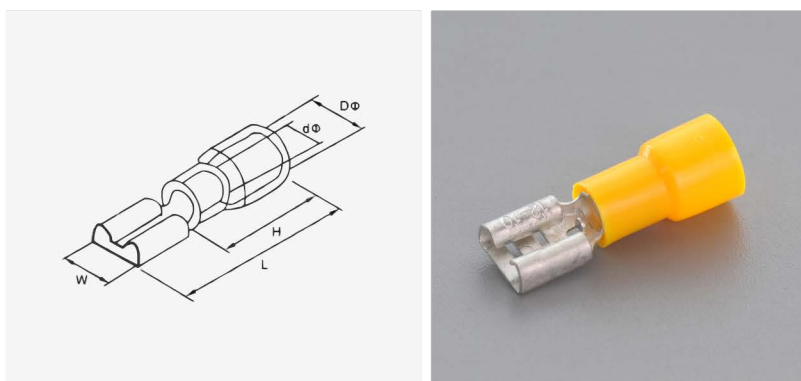

型号 Item NO	导线截面mm ² Cable Size A.W.G	最大电流 Max Current	接插规格 Connecting spec.	材料厚度 Thickness (mm)	尺寸 Dimension(mm)					颜色 Color
					W	Dφ	dφ	L	H	
FDDN 1.25-110(5)	0.5-1.5 (22-16)	10A	0.5×2.8	0.3	3.8	4.1	1.7	19.0	11.0	红 red
FDDN 1.25-110(8)			0.8×2.8		3.8	4.1	1.7	19.0		
FDDN 1.25-187(5)			0.5×4.75	0.4	5.6	4.1	1.7	19.0		
FDDN 1.25-187(8)			0.8×4.75		5.6	4.1	1.7	19.0		
FDDN 1.25-205(5)			0.5×5.2	6.5	4.1	1.7	20.0			
FDDN 1.25-205(8)			0.8×5.2	6.5	4.1	1.7	20.0			
FDDN 1.25-250			0.8×6.35	7.6	4.1	1.7	20.7			

型号 Item NO	导线截面mm ² Cable Size A.W.G	最大电流 Max Current	接插规格 Connecting spec.	材料厚度 Thickness (mm)	尺寸 Dimension(mm)					颜色 Color
					W	Dφ	dφ	L	H	
FDDN 2-110(5)	1.5-2.5 (16-14)	15A	0.5×2.8	0.3	3.8	4.7	2.3	19.7	11.5	蓝 blue
FDDN 2-110(8)			0.8×2.8		3.8	4.7	2.3	19.7		
FDDN 2-187(5)			0.5×4.75	0.4	5.6	4.7	2.3	19.7		
FDDN 2-187(8)			0.8×4.75		5.6	4.7	2.3	19.7		
FDDN 2-205(5)			0.5×5.2	6.5	4.7	2.3	20.5			
FDDN 2-205(8)			0.8×5.2	6.5	4.7	2.3	20.5			
FDDN 2-250			0.8×6.35	7.6	4.7	2.3	20.8			

型号 Item NO	导线截面mm ² Cable Size A.W.G	最大电流 Max Current	接插规格 Connecting spec.	材料厚度 Thickness (mm)	尺寸 Dimension(mm)					颜色 Color
					W	Dφ	dφ	L	H	
FDDN 5.5-250	4-6 (12-10)	24A	0.8×6.35	0.4	7.6	6.6	3.4	23.3	14.0	黄 yellow

尼龙绝缘护套公插端子

(适用于软线)

Nylon-Insulating Male Terminal

(Apply in flexible wire)

材质: 黄铜 Terminal Body: Brass
 护套: 尼龙 Insulation: Nylon
 温度: 105℃ Temperature: 105℃
 表面处理: 镀锡 Plating: Tin

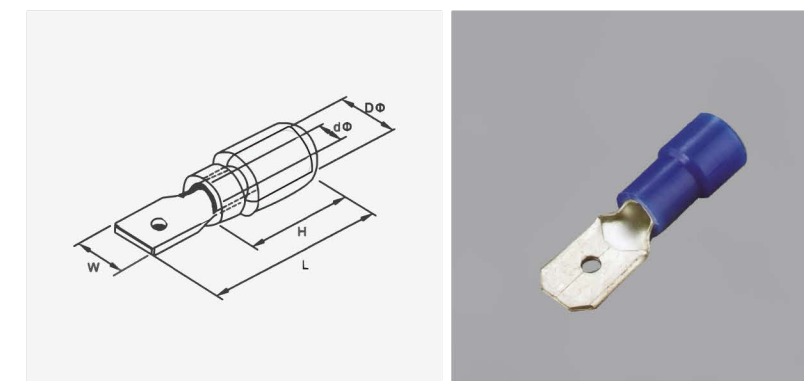

型号 Item NO	导线截面mm ² Cable Size A.W.G	最大电流 Max Current	接插规格 Connecting spec.	材料厚度 Thickness (mm)	尺寸 Dimension(mm)					颜色 Color
					W	Dφ	dφ	L	H	
MDDN 1.25-110(5)	0.5-1.5 (22-16)	10A	0.5×2.8	0.5	2.8	4.0	1.7	17.7	11.0	红 red
MDDN 1.25-110(8)			0.8×2.8	0.8	2.8	4.3	1.7	17.7		
MDDN 1.25-187(5)			0.5×4.75	0.5	4.75	4.0	1.7	21.0		
MDDN 1.25-187(8)			0.8×4.75	0.8	4.75	4.0	1.7	21.0		
MDDN 1.25-250			0.8×6.35	0.4×2	6.35	4.1	1.7	21.5		

型号 Item NO	导线截面mm ² Cable Size A.W.G	最大电流 Max Current	接插规格 Connecting spec.	材料厚度 Thickness (mm)	尺寸 Dimension(mm)					颜色 Color
					W	Dφ	dφ	L	H	
MDDN 2-187(5)	1.5-2.5 (16-14)	15A	0.5×4.75	0.5	4.75	4.3	2.3	20.0	11.0	蓝 blue
MDDN 2-187(8)			0.8×4.75	0.8	4.75	4.3	2.3	20.0		
MDDN 2-250			0.8×6.35	0.4×2	6.35	4.3	2.3	21.0		

型号 Item NO	导线截面mm ² Cable Size A.W.G	最大电流 Max Current	接插规格 Connecting spec.	材料厚度 Thickness (mm)	尺寸 Dimension(mm)					颜色 Color
					W	Dφ	dφ	L	H	
MDDN 5.5-250	4-6 (12-10)	24A	0.8×6.35	0.4x2	6.35	6.6	3.4	25.0	14.0	黄 yellow

PVC绝缘护套母插端子

(加铜套)(适用于软线)

Vinyl-Insulated Female Terminal
(Double Copper Sleeve)(apply In Flexible Wire)

材质: 黄铜 Terminal Body: Brass
 护套: PVC Insulation: Vinyl
 温度: 105℃ Temperature: 105℃
 表面处理: 镀锡 Plating: Tin

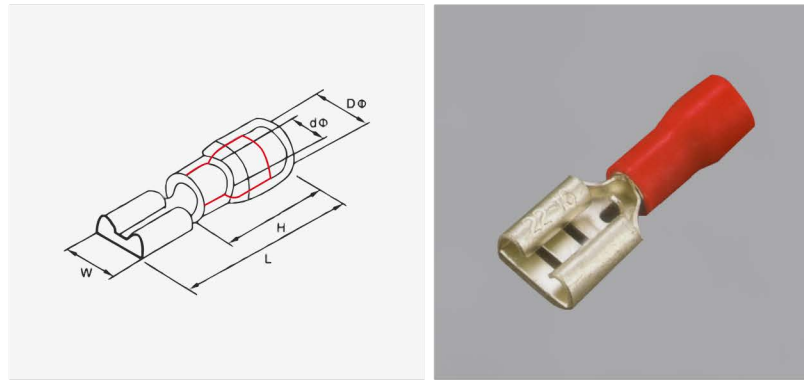

型号 Item NO	导线截面mm ² Cable Size A.W.G	最大电流 Max Current	接插规格 Connecting spec.	材料厚度 Thickness (mm)	尺寸 Dimension(mm)					颜色 Color			
					W	Dφ	dφ	L	H				
FDD 1.25-110 D(5)	0.5-1.5 (22-16)	10A	0.5×2.8	0.3	3.8	3.8	1.7	19.0	10.5	红 red			
FDD 1.25-110 D(8)			0.8×2.8		3.8	3.8	1.7	19.0					
FDD 1.25-187 D(5)			0.5×4.75	0.4	5.6	3.8	1.7	19.0					
FDD 1.25-187 D(8)			0.8×4.75		5.6	3.8	1.7	19.0					
FDD 1.25-20 D5(5)			0.5×5.2		6.5	3.8	1.7	20.0					
FDD 1.25-205 D(8)			0.8×5.2		6.5	3.8	1.7	20.0					
FDD 1.25-250 D					0.8×6.35	7.6	3.8	1.7			20.5		

型号 Item NO	导线截面mm ² Cable Size A.W.G	最大电流 Max Current	接插规格 Connecting spec.	材料厚度 Thickness (mm)	尺寸 Dimension(mm)					颜色 Color			
					W	Dφ	dφ	L	H				
FDD 2-110 D(5)	1.5-2.5 (16-14)	15A	0.5×2.8	0.3	3.8	4.4	2.3	19.0	10.5	蓝 blue			
FDD 2-110 D(8)			0.8×2.8		3.8	4.4	2.3	19.0					
FDD 2-187 D(5)			0.5×4.75	0.4	5.6	4.4	2.3	19.0					
FDD 2-187 D(8)			0.8×4.75		5.6	4.4	2.3	19.0					
FDD 2-205 D(5)			0.5×5.2		6.5	4.4	2.3	20.0					
FDD 2-205 D(8)			0.8×5.2		6.5	4.4	2.3	20.0					
FDD 2-250 D					0.8×6.35	7.6	4.4	2.3			21.0		

型号 Item NO	导线截面mm ² Cable Size A.W.G	最大电流 Max Current	接插规格 Connecting spec.	材料厚度 Thickness (mm)	尺寸 Dimension(mm)					颜色 Color
					W	Dφ	dφ	L	H	
FDDN 5.5-250 D	4-6 (12-10)	24A	0.8×6.35	0.4	7.6	5.7	3.4	23.0	13.0	黄 yellow

尼龙绝缘护套母插端子

(加铜套)(适用于软线)

Nylon-Insulated Female Terminal
(Double Copper Sleeve)(apply In Flexible Wire)

材质: 黄铜 Terminal Body: Brass
 护套: 尼龙 Insulation: Nylon
 温度: 105℃ Temperature: 105℃
 表面处理: 镀锡 Plating: Tin

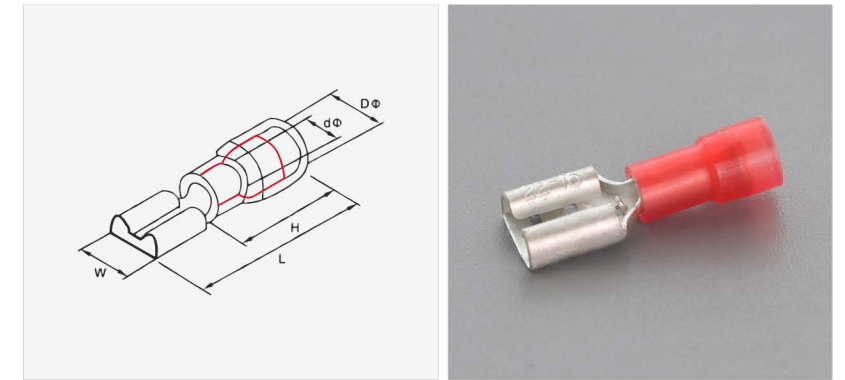

型号 Item NO	导线截面mm ² Cable Size A.W.G	最大电流 Max Current	接插规格 Connecting spec.	材料厚度 Thickness (mm)	尺寸 Dimension(mm)					颜色 Color			
					W	Dφ	dφ	L	H				
FDDN 1.25-110 D(5)	0.5-1.5 (22-16)	10A	0.5×2.8	0.3	3.8	3.8	1.7	19.2	11.0	红 red			
FDDN 1.25-110 D(8)			0.8×2.8		3.8	3.8	1.7	19.2					
FDDN 1.25-187 D(5)			0.5×4.75	0.4	5.6	3.8	1.7	19.2					
FDDN 1.25-187 D(8)			0.8×4.75		5.6	3.8	1.7	19.2					
FDDN 1.25-20 D5(5)			0.5×5.2		6.5	3.8	1.7	20.0					
FDDN 1.25-205 D(8)			0.8×5.2		6.5	3.8	1.7	20.0					
FDDN 1.25-250 D					0.8×6.35	7.6	3.8	1.7			21.0		

型号 Item NO	导线截面mm ² Cable Size A.W.G	最大电流 Max Current	接插规格 Connecting spec.	材料厚度 Thickness (mm)	尺寸 Dimension(mm)					颜色 Color			
					W	Dφ	dφ	L	H				
FDDN 2-110 D(5)	1.5-2.5 (16-14)	15A	0.5×2.8	0.3	3.8	4.4	2.3	19.7	11.5	蓝 blue			
FDDN 2-110 D(8)			0.8×2.8		3.8	4.4	2.3	19.7					
FDDN 2-187 D(5)			0.5×4.75	0.4	5.6	4.4	2.3	19.7					
FDDN 2-187 D(8)			0.8×4.75		5.6	4.4	2.3	19.7					
FDDN 2-205 D(5)			0.5×5.2		6.5	4.4	2.3	20.5					
FDDN 2-205 D(8)			0.8×5.2		6.5	4.4	2.3	20.5					
FDDN 2-250 D					0.8×6.35	7.6	4.4	2.3			21.0		
FDDN 2-312 D					0.8x8.0	9.0	4.4	2.3			23.5		

型号 Item NO	导线截面mm ² Cable Size A.W.G	最大电流 Max Current	接插规格 Connecting spec.	材料厚度 Thickness (mm)	尺寸 Dimension(mm)					颜色 Color
					W	Dφ	dφ	L	H	
FDDN 5.5-250 D	4-6 (12-10)	24A	0.8×6.35	0.4	7.6	5.7	3.4	23.6	14.0	黄 yellow
FDDN 5.5-375 D			1.2x9.4	0.5	10.9	5.7	3.4	29.6		

尼龙绝缘护套公插端子

(加铜套)(适用于软线)

Nylon-Insulated Female Terminal
(Double Copper Sleeve)(apply In Flexible Wire)

材质: 黄铜 Terminal Body: Brass
 护套: 尼龙 Insulation: Nylon
 温度: 105°C Temperature: 105°C
 表面处理: 镀锡 Plating: Tin

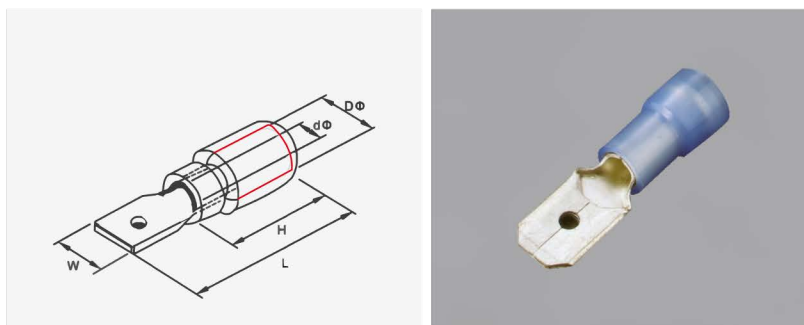

型号 Item NO	导线截面mm ² Cable Size A.W.G	最大电流 Max Current	接插规格 Connecting spec.	材料厚度 Thickness (mm)	尺寸 Dimension(mm)					颜色 Color
					W	Dφ	dφ	L	H	
MDDN 1.25-110 D(5)	0.5-1.5 (22-16)	10A	0.5 × 2.8	0.5	2.8	4.0	1.7	17.7	11.0	红 red
MDDN 1.25-110 D(8)			0.8 × 2.8	0.8	2.8	4.3	1.7	17.7		
MDDN 1.25-187 D(5)			0.5 × 4.75	0.5	4.75	4.0	1.7	21.0		
MDDN 1.25-187 D(8)			0.8 × 4.75	0.8	4.75	4.3	1.7	21.0		
MDDN 1.25-250 D			0.8 × 6.35	0.4 × 2	6.35	4.0	1.7	21.5		

型号 Item NO	导线截面mm ² Cable Size A.W.G	最大电流 Max Current	接插规格 Connecting spec.	材料厚度 Thickness (mm)	尺寸 Dimension(mm)					颜色 Color
					W	Dφ	dφ	L	H	
MDDN 2-187 D(5)	1.5-2.5 (16-14)	15A	0.5 × 4.75	0.5	4.75	4.8	2.3	21.0	11.0	蓝 blue
MDDN 2-187 D(8)			0.8 × 4.75	0.8	4.75	4.9	2.3	21.0		
MDDN 2-250 D			0.8 × 6.35	0.4 × 2	6.35	4.7	2.3	22.0		

型号 Item NO	导线截面mm ² Cable Size A.W.G	最大电流 Max Current	接插规格 Connecting spec.	材料厚度 Thickness (mm)	尺寸 Dimension(mm)					颜色 Color
					W	Dφ	dφ	L	H	
MDDN 5.5-250 D	4-6 (12-10)	24A	0.8 × 6.35	0.4x2	6.35	6.6	3.4	25.0	14.0	黄 yellow

PVC全绝缘护套母插端子

(适用于软线)

Vinyl-fully Insulated female Terminal
(Apply in flexible wire)

材质: 黄铜 Terminal Body: Brass
 护套: PVC Insulation: Vinyl
 表面处理: 镀锡 Plating: Tin

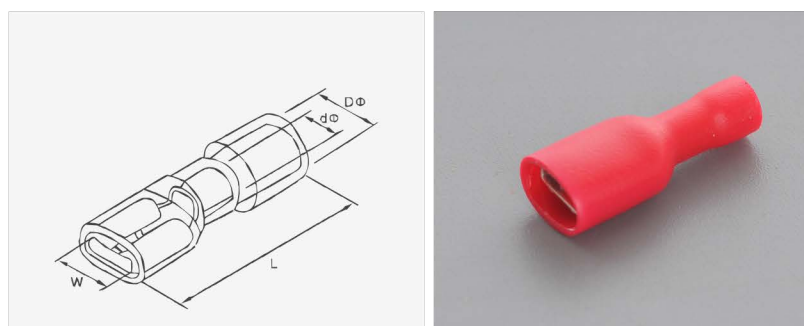

型号 Item NO	导线截面mm ² Cable Size A.W.G	最大电流 Max Current	接插规格 Connecting spec.	材料厚度 Thickness (mm)	尺寸 Dimension(mm)				颜色 Color
					W	Dφ	dφ	L	
FDFD1.25-187(5)	1.5-2.5 (16-14)	10A	0.5 × 4.75	0.4	5.6	3.7	1.7	20.0	红 red
FDFD1.25-187(8)			0.8 × 4.75		5.6	3.7	1.7	20.0	
FDFD1.25-250			0.8 × 6.35		7.6	3.7	1.7	22.0	

型号 Item NO	导线截面mm ² Cable Size A.W.G	最大电流 Max Current	接插规格 Connecting spec.	材料厚度 Thickness (mm)	尺寸 Dimension(mm)				颜色 Color
					W	Dφ	dφ	L	
FDFD2-187(5)	1.5-2.5 (16-14)	15A	0.8 × 4.75	0.4	5.6	4.3	2.3	20.0	蓝 blue
FDFD 2-187(8)			0.8 × 4.75		5.6	4.3	2.3	20.0	
FDFD 2-250			0.8 × 6.35		7.6	4.3	2.3	23.0	

型号 Item NO	导线截面mm ² Cable Size A.W.G	最大电流 Max Current	接插规格 Connecting spec.	材料厚度 Thickness (mm)	尺寸 Dimension(mm)				颜色 Color
					W	Dφ	dφ	L	
FDFD 5.5-250	4-6 (12-10)	24A	0.8 × 6.35	0.4	7.6	5.4	3.4	24.0	黄 yellow

尼龙绝缘护套母插端子(椭圆口)

(适用于软线)

Nylon-Insulated Female Terminal
(apply In Flexible Wire)

材质: 黄铜 Terminal Body: Brass
 护套: 尼龙 Insulation: Nylon
 温度: 105°C Temperature: 105°C
 表面处理: 镀锡 Plating: Tin

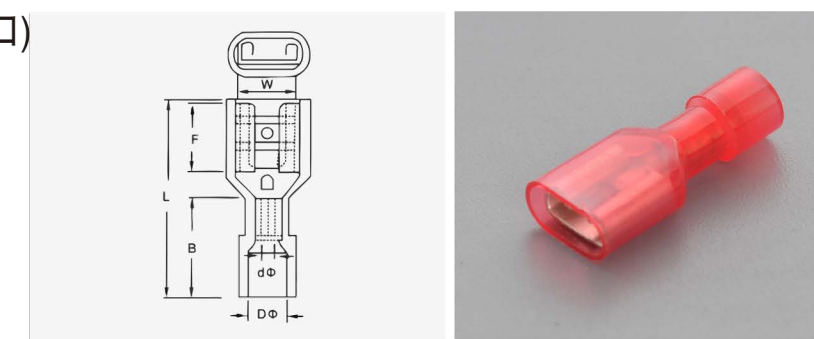

型号 Item NO	导线截面mm ² Cable Size A.W.G	最大电流 Max Current	接插规格 Connecting spec.	材料厚度 Thickness (mm)	尺寸 Dimension(mm)						颜色 Color
					W	F	L	B	Dφ	dφ	
DFDN 1.25-110(5)	0.5-1.5 (22-16)	10A	0.5 × 2.8	0.5	4.0	6.4	19.0	10.5	4.5	1.7	红 red
DFDN 1.25-110(8)			0.8 × 2.8	0.8	4.0	6.4	19.0	10.5	4.5		
DFDN 1.25-187(5)			0.5 × 4.75	0.5	5.0	6.4	21.4	10.5	3.5		
DFDN 1.25-187(8)			0.8 × 4.75	0.8	5.0	6.4	21.4	10.5	3.5		
DFDN 1.25-250			0.8 × 6.35	0.4 × 2	7.6	7.3	22.0	11.0	4.5		

型号 Item NO	导线截面mm ² Cable Size A.W.G	最大电流 Max Current	接插规格 Connecting spec.	材料厚度 Thickness (mm)	尺寸 Dimension(mm)						颜色 Color
					W	F	L	B	Dφ	dφ	
DFDN 2-187(5)	1.5-2.5 (16-14)	15A	0.8 × 4.75	0.4	5.0	6.4	21.0	10.5	4.2	2.3	蓝 blue
DFDN 2-187(8)			0.8 × 4.75		5.0	6.4	21.40	10.5	4.2	2.3	
DFDN 2-250			0.8 × 6.35		7.6	7.3	22.4	11.0	4.8	2.3	

型号 Item NO	导线截面mm ² Cable Size A.W.G	最大电流 Max Current	接插规格 Connecting spec.	材料厚度 Thickness (mm)	尺寸 Dimension(mm)						颜色 Color
					W	F	L	B	Dφ	dφ	
DFDN 5.5-250	4-6 (12-10)	24A	0.8 × 6.35	0.4	7.6	7.3	24.2	13.0	6.7	3.4	黄 yellow

尼龙全绝缘护套公插端子(椭圆口)

(适用于软线)

Nylon-Insulated male Terminal
(apply In Flexible Wire)

材质: 黄铜 Terminal Body: Brass
 护套: 尼龙 Insulation: Nylon
 温度: 105°C Temperature: 105°C
 表面处理: 镀锡 Plating: Tin

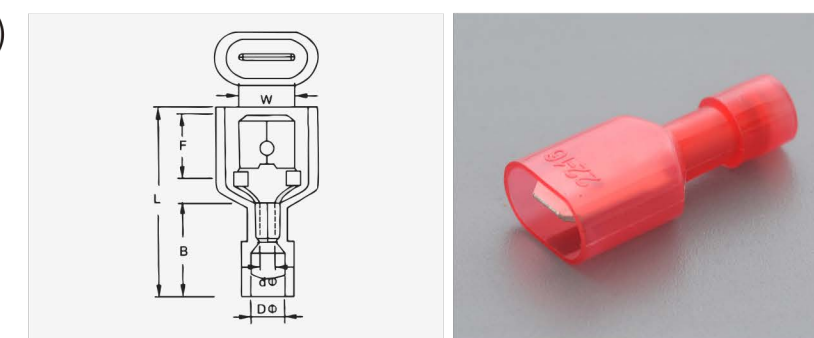

型号 Item NO	导线截面mm ² Cable Size A.W.G	最大电流 Max Current	接插规格 Connecting spec.	材料厚度 Thickness (mm)	尺寸 Dimension(mm)						颜色 Color
					W	F	L	B	Dφ	dφ	
MDFN 1.25-250	0.5-1.5 (22-16)	10A	0.8x6.35	0.4	6.35	7.7	24.5	11.0	4.5	1.7	红 red

型号 Item NO	导线截面mm ² Cable Size A.W.G	最大电流 Max Current	接插规格 Connecting spec.	材料厚度 Thickness (mm)	尺寸 Dimension(mm)						颜色 Color
					W	F	L	B	Dφ	dφ	
MDFN 2-250	1.5-2.5 (16-14)	15A	0.8x6.35	0.4	6.35	7.7	24.5	11.0	4.5	2.3	蓝 blue

型号 Item NO	导线截面mm ² Cable Size A.W.G	最大电流 Max Current	接插规格 Connecting spec.	材料厚度 Thickness (mm)	尺寸 Dimension(mm)						颜色 Color
					W	F	L	B	Dφ	dφ	
MDFN 5.5-250	4-6 (12-10)	24A	0.8x6.35	0.4	6.35	7.7	25.5	13.0	6.5	3.4	黄 yellow

PVC全绝缘护套母插端子

(加铜套)(适用于软线)

Vinyl-fully Insulated female Terminal

(Double Copper Sleeve)(apply In Flexible Wire)

材质: 黄铜 Terminal Body: Brass
 护套: PVC Insulation: Vinyl
 表面处理: 镀锡 Plating: Tin

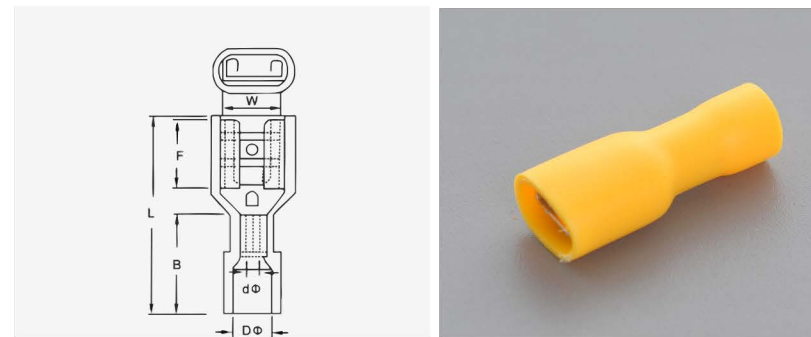

型号 Item NO	导线截面mm ² Cable Size A.W.G	最大电流 Max Current	接插规格 Connecting spec.	材料厚度 Thickness (mm)	尺寸 Dimension(mm)				颜色 Color
					W	D φ	d φ	L	
FDFD1.25-187D(5)	1.5-2.5 (16-14)	10A	0.5 × 4.75	0.4	5.6	3.8	1.7	20.0	红 red
FDFD1.25-187D(8)			0.8 × 4.75		5.6	3.8	1.7	20.0	
FDFD1.25-250D			0.8 × 6.35		7.6	3.8	1.7	21.5	

型号 Item NO	导线截面mm ² Cable Size A.W.G	最大电流 Max Current	接插规格 Connecting spec.	材料厚度 Thickness (mm)	尺寸 Dimension(mm)				颜色 Color
					W	D φ	d φ	L	
FDFD2-187D(5)	1.5-2.5 (16-14)	15A	0.8 × 4.75	0.4	5.6	4.3	2.3	20.0	蓝 blue
FDFD 2-187D(8)			0.8 × 4.75		5.6	4.3	2.3	20.0	
FDFD 2-250D			0.8 × 6.35		7.6	4.3	2.3	21.5	

型号 Item NO	导线截面mm ² Cable Size A.W.G	最大电流 Max Current	接插规格 Connecting spec.	材料厚度 Thickness (mm)	尺寸 Dimension(mm)				颜色 Color
					W	D φ	d φ	L	
FDFD 5.5-250D	4-6 (12-10)	24A	0.8 × 6.35	0.4	7.6	5.4	3.4	25.5	黄 yellow

尼龙绝缘护套母插端子(椭圆口)

(加铜套)(适用于软线)

Nylon-Insulated Female Terminal

(Double Copper Sleeve)(apply In Flexible Wire)

材质: 黄铜 Terminal Body: Brass
 护套: 尼龙 Insulation: Nylon
 温度: 105°C Temperature: 105°C
 表面处理: 镀锡 Plating: Tin

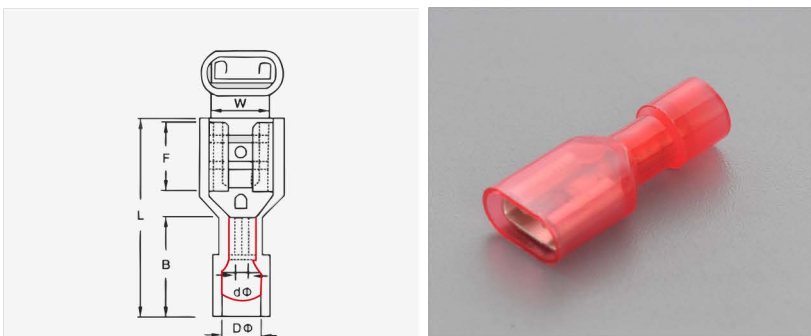

型号 Item NO	导线截面mm ² Cable Size A.W.G	最大电流 Max Current	接插规格 Connecting spec.	材料厚度 Thickness (mm)	尺寸 Dimension(mm)					颜色 Color	
					W	F	L	B	D φ		d φ
FDFN 1.25-187 D(5)	1.5-2.5 (16-14)	10A	0.5 × 4.75	0.4	5.0	6.4	21.0	10.5	.38	1.7	红 red
FDFN 1.25-187 D(8)			0.8 × 4.75		5.0	6.4	21.0	10.5			
FDFN 1.25-250 D			0.8 × 6.35		6.6	7.3	22.0	11.0			

型号 Item NO	导线截面mm ² Cable Size A.W.G	最大电流 Max Current	接插规格 Connecting spec.	材料厚度 Thickness (mm)	尺寸 Dimension(mm)					颜色 Color	
					W	F	L	B	D φ		d φ
FDFN 2-187 D(5)	1.5-2.5 (16-14)	15A	0.8 × 4.75	0.4	5.0	6.4	21.4	10.5	4.3	2.3	蓝 blue
FDFN 2-187 D(8)			0.8 × 4.75		5.0	6.4	21.4	10.5			
FDFN 2-250 D			0.8 × 6.35		7.6	7.3	22.0	11.0			

型号 Item NO	导线截面mm ² Cable Size A.W.G	最大电流 Max Current	接插规格 Connecting spec.	材料厚度 Thickness (mm)	尺寸 Dimension(mm)					颜色 Color	
					W	F	L	B	D φ		d φ
FDFN5.5-250D	4-6 (12-10)	24A	0.8 × 6.35	0.4	6.6	7.3	24.4	13.0	5.7	3.4	黄 yellow

尼龙全绝缘护套公插端子(椭圆口)

(加铜套)(适用于软线)

Nylon-fully Insulated Male Terminal

(Double Copper Sleeve)(apply In Flexible Wire)

材质: 黄铜 Terminal Body: Brass
 护套: 尼龙 Insulation: Nylon
 温度: 105°C Temperature: 105°C
 表面处理: 镀锡 Plating: Tin

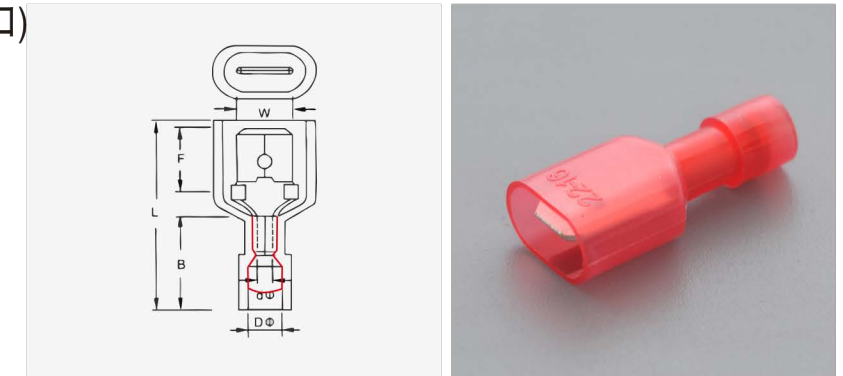

型号 Item NO	导线截面mm ² Cable Size A.W.G	最大电流 Max Current	接插规格 Connecting spec.	材料厚度 Thickness (mm)	尺寸 Dimension(mm)					颜色 Color	
					W	F	L	B	D φ		d φ
MDFN 1.25-250 D	0.5-1.5 (22-16)	10A	0.8x6.35	0.4	6.35	7.7	24.5	11.0	3.8	1.7	红 red

型号 Item NO	导线截面mm ² Cable Size A.W.G	最大电流 Max Current	接插规格 Connecting spec.	材料厚度 Thickness (mm)	尺寸 Dimension(mm)					颜色 Color	
					W	F	L	B	D φ		d φ
MDFN 2-250 D	1.5-2.5 (16-14)	15A	0.8x6.35	0.4	6.35	7.7	24.5	11.0	4.4	2.3	蓝 blue

型号 Item NO	导线截面mm ² Cable Size A.W.G	最大电流 Max Current	接插规格 Connecting spec.	材料厚度 Thickness (mm)	尺寸 Dimension(mm)					颜色 Color	
					W	F	L	B	D φ		d φ
MDFN5.5-250 D	4-6 (12-10)	24A	0.8x6.35	0.4	6.35	7.7	25.5	13.0	5.7	3.4	黄 yellow

尼龙全绝缘护套旗形母插端子

(适用于软线)

Nylon-Flag Female Insulated Joint Terminal

(apply In Flexible Wire)

材质: 黄铜 Terminal Body: Brass
 护套: 尼龙 Insulation: Nylon
 温度: 105°C Temperature: 105°C
 表面处理: 镀锡 Plating: Tin

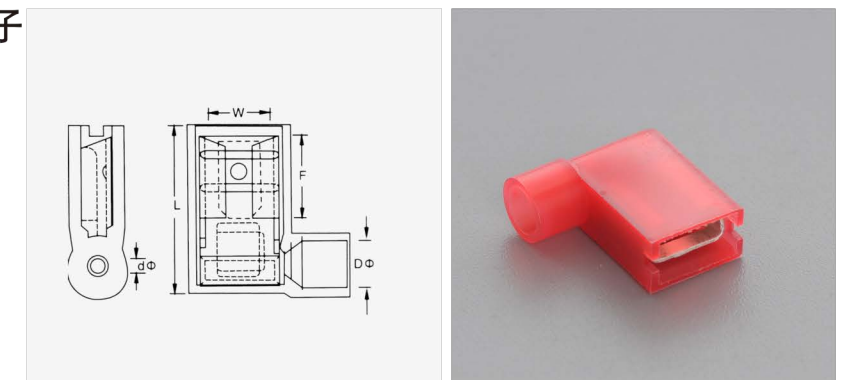

型号 Item NO	导线截面mm ² Cable Size A.W.G	最大电流 Max Current	接插规格 Connecting spec.	材料厚度 Thickness (mm)	尺寸 Dimension(mm)					颜色 Color
					W	F	L	D φ	d φ	
FLDNY 1.25-250	0.5-1.5 (22-16)	10A	0.8x6.35	0.4	7.6	10.5	15.0	4.4	1.7	红 red

型号 Item NO	导线截面mm ² Cable Size A.W.G	最大电流 Max Current	接插规格 Connecting spec.	材料厚度 Thickness (mm)	尺寸 Dimension(mm)					颜色 Color
					W	F	L	D φ	d φ	
FLDNY 2-250	1.5-2.5 (16-14)	15A	0.8x6.35	0.4	7.6	10.0	15.7	4.5	2.3	蓝 blue

型号 Item NO	导线截面mm ² Cable Size A.W.G	最大电流 Max Current	接插规格 Connecting spec.	材料厚度 Thickness (mm)	尺寸 Dimension(mm)					颜色 Color
					W	F	L	D φ	d φ	
FLDNY 5.5-250	4-6 (12-10)	24A	0.8x6.35	0.4	7.6	10.0	16.0	6.5	3.4	黄 yellow

PVC绝缘护套背形公母插端子

(适用于软线)

Vinyl-Insulated Female Terminal
(apply In Flexible Wire)

材质: 黄铜 Terminal Body: Brass
护套: PVC Insulation: Vinyl
表面处理: 镀锡 Plating: Tin

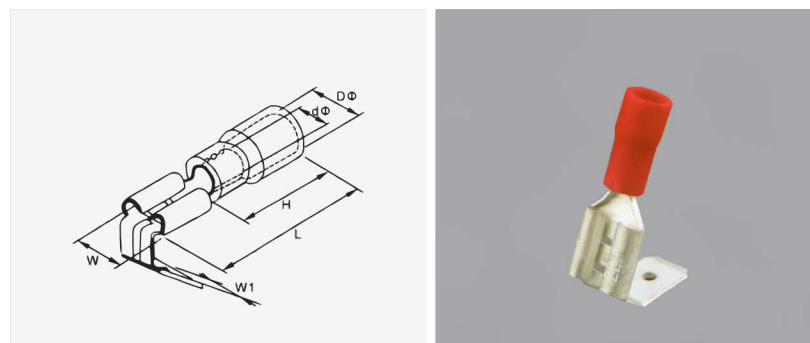

型号 Item NO	导线截面mm ² Cable Size A.W.G	最大电流 Max Current	接插规格 Connecting spec.	材料厚度 Thickness (mm)	尺寸 Dimension(mm)						颜色 Color
					W	W1	H	L	Dφ	dφ	
PBDD 1.25-250	0.5-1.5 (22-16)	10A	0.8×6.35	0.4	7.4	6.35	10.5	21.5	3.8	1.7	红 red
PBDD 2-250	1.5-2.5 (16-14)	15A	0.8×6.35		7.4	6.35	10.5	21.5	4.3	2.3	蓝 Blue
PBDD 5.5-250	4-6 (12-10)	24A	0.8×6.35		7.4	6.35	10.5	24.5	5.7	3.4	黄 yellow

尼龙绝缘护套背形公母插端子

(适用于软线)

Nylon-Insulated Female Terminal
(apply In Flexible Wire)

材质: 黄铜 Terminal Body: Brass
护套: 尼龙 Insulation: Nylon
温度: 105oC Temperature : 105oC
表面处理: 镀锡 Plating: Tin

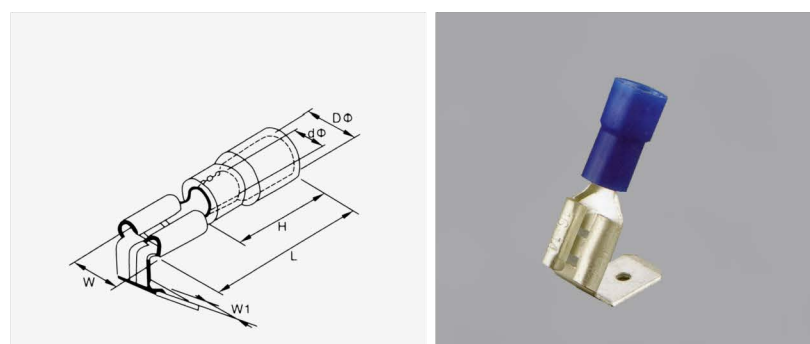

型号 Item NO	导线截面mm ² Cable Size A.W.G	最大电流 Max Current	接插规格 Connecting spec.	材料厚度 Thickness (mm)	尺寸 Dimension(mm)						颜色 Color
					W	W1	H	L	Dφ	dφ	
PBDDN 1.25-250	0.5-1.5 (22-16)	10A	0.8×6.35	0.4	7.4	6.35	11.0	21.5	4.3	1.7	红 red
PBDDN 2-250	1.5-2.5 (16-14)	15A	0.8×6.35		7.4	6.35	11.0	21.5	4.8	2.3	蓝 Blue
PBDDN 5.5-250	4-6 (12-10)	24A	0.8×6.35		7.4	6.35	11.0	24.5	5.7	3.4	黄 yellow

尼龙全绝缘护套背形公母插端子

(适用于软线)

Nylon-Insulated Female Terminal
(apply In Flexible Wire)

材质: 黄铜 Terminal Body: Brass
护套: 尼龙 Insulation: Nylon
温度: 105℃ Temperature : 105℃
表面处理: 镀锡 Plating: Tin

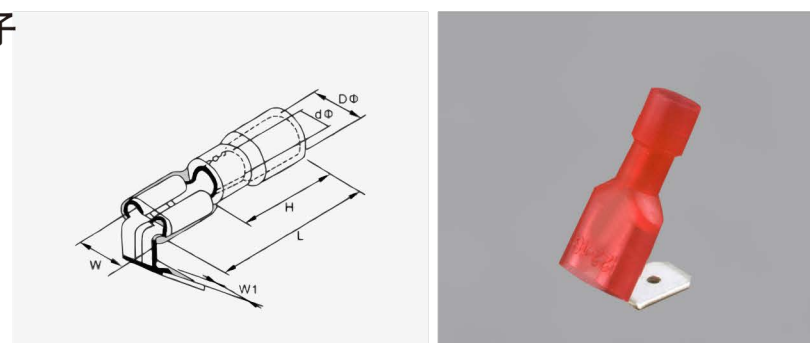

型号 Item NO	导线截面mm ² Cable Size A.W.G	最大电流 Max Current	接插规格 Connecting spec.	材料厚度 Thickness (mm)	尺寸 Dimension(mm)						颜色 Color
					W	W1	H	L	Dφ	dφ	
PBDFN 1.25-250	0.5-1.5 (22-16)	10A	0.8×6.35	0.4	7.4	6.35	11.5	22.0	4.3	1.7	红 red
PBDFN 2-250	1.5-2.5 (16-14)	15A	0.8×6.35		7.4	6.35	11.0	22.3	4.3	2.3	蓝 Blue
PBDFN 5.5-250	4-6 (12-10)	24A	0.8×6.35		7.4	6.35	14.0	24.5	5.7	3.4	黄 yellow

尼龙全绝缘护套背形公母插端子

(加铜套)(适用于软线)

Nylon-insulated Female Terminal
(Double Copper Sleeve)(apply In Flexible Wire)

材质: 黄铜 Terminal Body: Brass
护套: 尼龙 Insulation: Nylon
温度: 105℃ Temperature : 105℃
表面处理: 镀锡 Plating: Tin

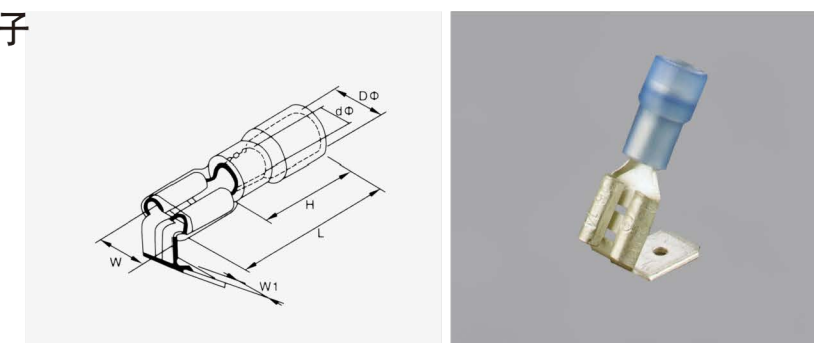

型号 Item NO	导线截面mm ² Cable Size A.W.G	最大电流 Max Current	接插规格 Connecting spec.	材料厚度 Thickness (mm)	尺寸 Dimension(mm)						颜色 Color
					W	W1	H	L	Dφ	dφ	
PBDFN 1.25-250D	0.5-1.5 (22-16)	10A	0.8×6.35	0.4	7.4	6.35	11.0	21.5	4.3	1.7	红 red
PBDFN 2-250D	1.5-2.5 (16-14)	15A	0.8×6.35		7.4	6.35	11.0	21.5	4.3	2.3	蓝 Blue
PBDFN 5.5-250D	4-6 (12-10)	24A	0.8×6.35		7.4	6.35	14.0	24.5	5.7	3.4	黄 yellow

尼龙全绝缘护套背形公母插端子

(加铜套)(适用于软线)

Nylon-Insulated Female Terminal
(Double Copper Sleeve)(apply In Flexible Wire)

材质: 黄铜 Terminal Body: Brass
护套: 尼龙 Insulation: Nylon
温度: 105℃ Temperature : 105℃
表面处理: 镀锡 Plating: Tin

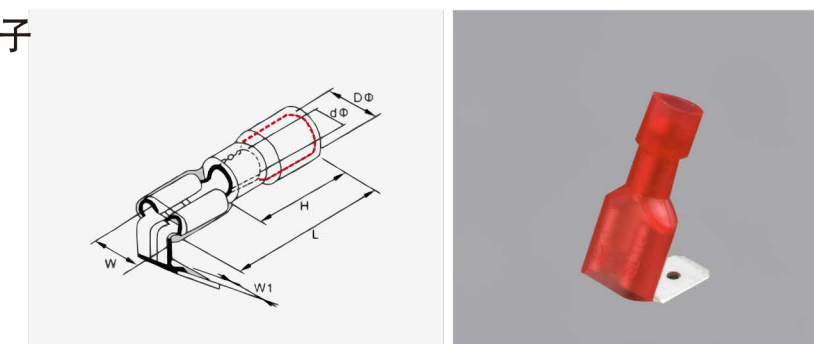

型号 Item NO	导线截面mm ² Cable Size A.W.G	最大电流 Max Current	接插规格 Connecting spec.	材料厚度 Thickness (mm)	尺寸 Dimension(mm)						颜色 Color
					W	W1	H	L	Dφ	dφ	
PBDFN 1.25-250D	0.5-1.5 (22-16)	10A	0.8×6.35	0.4	7.4	6.35	11.5	22.0	4.3	1.7	红 red
PBDFN 2-250D	1.5-2.5 (16-14)	15A	0.8×6.35		7.4	6.35	11.0	22.3	4.3	2.3	蓝 Blue
PBDFN 5.5-250D	4-6 (12-10)	24A	0.8×6.35		7.4	6.35	14.0	24.5	5.7	3.4	黄 yellow

PVC全绝缘护套子弹形母插端子

(适用于软线)

Vinyl -fully Insulated bullet receptacles
(apply In Flexible Wire)

材质: 黄铜 Terminal Body: Brass
护套: PVC Insulation: Vinyl
表面处理: 镀锡 Plating: Tin

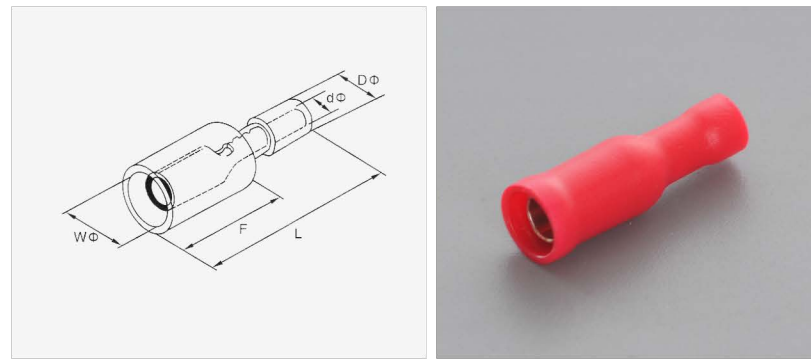

型号 Item NO	导线截面mm ² Cable Size A.W.G	最大电流 Max Current	材料厚度 Thickness (mm)	尺寸 Dimension(mm)					颜色 Color
				W φ	D φ	d φ	F	L	
FRD1.25-156	0.5-1.5 (22-16)	10A	0.4	6.0	5.6	1.7	13.0	23.0	红 red

型号 Item NO	导线截面mm ² Cable Size A.W.G	最大电流 Max Current	材料厚度 Thickness (mm)	尺寸 Dimension(mm)					颜色 Color
				W	D φ	d φ	F	L	
FRD2-156	1.5-2.5 (16-14)	15A	0.4	6.1	6.3	2.3	14.0	24.5	蓝 blue
FRD2-195	1.5-2.5 (16-14)	15A	0.4	6.5	6.3	2.3	14.0	24.5	蓝 blue

型号 Item NO	导线截面mm ² Cable Size A.W.G	最大电流 Max Current	材料厚度 Thickness (mm)	尺寸 Dimension(mm)					颜色 Color
				W	D φ	d φ	F	L	
FRD5.5-195	4-6 (12-10)	24A	0.4	7.0	7.2	3.4	14.0	25.5	黄 yellow

PVC绝缘护套子弹形公插端子

(适用于软线)

Vinyl- Insulated Male Terminal
(apply In Flexible Wire)

材质: 黄铜 Terminal Body: Brass
护套: PVC Insulation: PVC
表面处理: 镀锡 Plating: Tin

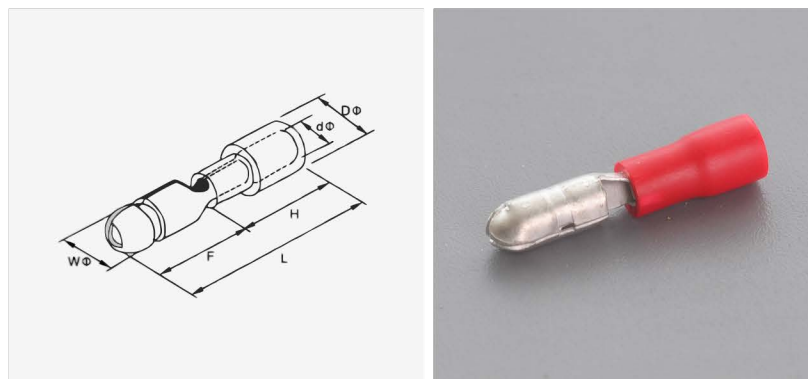

型号 Item NO	导线截面mm ² Cable Size A.W.G	最大电流 Max Current	材料厚度 Thickness (mm)	尺寸 Dimension(mm)						颜色 Color
				W φ	F	H	L	D φ	d φ	
MPD1.25-156	0.5-1.5 (22-16)	10A	0.4	4.0	11.0	11.0	22.0	3.7	1.7	红 red

型号 Item NO	导线截面mm ² Cable Size A.W.G	最大电流 Max Current	材料厚度 Thickness (mm)	尺寸 Dimension(mm)						颜色 Color
				W	F	H	L	D φ	d φ	
MPD2-156	1.5-2.5 (16-14)	15A	0.4	4.0	11.0	11.0	22.0	4.3	2.3	蓝 blue
MPD2-195	1.5-2.5 (16-14)	15A	0.4	5.0	11.0	11.0	22.0	4.3	2.3	蓝 blue

型号 Item NO	导线截面mm ² Cable Size A.W.G	最大电流 Max Current	材料厚度 Thickness (mm)	尺寸 Dimension(mm)						颜色 Color
				W	F	H	L	D φ	d φ	
MPD5.5-195	4-6 (12-10)	24A	0.4	5.0	13.5	13.5	22.0	5.3	3.4	黄 yellow

尼龙全绝缘护套子弹形母插端子

(适用于软线)

Nylon- Fully Insulated female bullet receptacle
(apply In Flexible Wire)

材质: 黄铜 Terminal Body: Brass
护套: 尼龙 Insulation: Nylon
温度: 105℃ Temperature: 105℃
表面处理: 镀锡 Plating: Tin

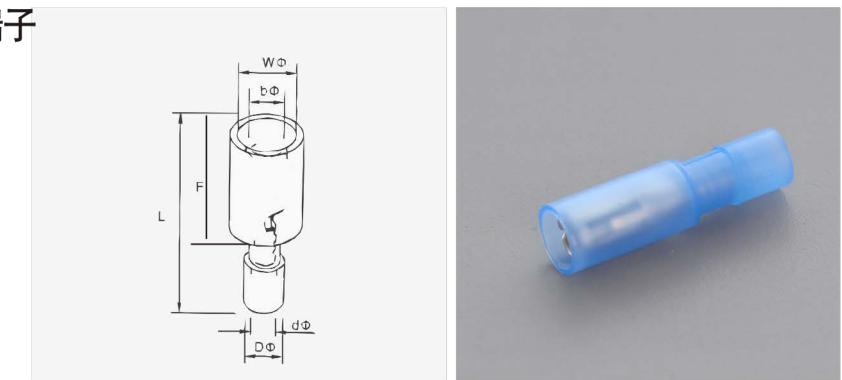

型号 Item NO	导线截面mm ² Cable Size A.W.G	最大电流 Max Current	材料厚度 Thickness (mm)	尺寸 Dimension(mm)						颜色 Color
				W φ	b φ	D φ	d φ	L	F	
FRFNY1.25-156	0.5-1.5 (22-16)	15A	0.4	6.9	3.9	4.3	1.8	24.5	14	红 red
FRFNY2-156	1.5-2.5 (16-14)	24A	0.4	6.9	3.9	4.5	2.4	24.5	14	蓝 blue

尼龙全绝缘护套子弹形公插端子

(适用于软线)

Nylon- Fully Insulated male bullet receptacle
(apply In Flexible Wire)

材质: 黄铜 Terminal Body: Brass
护套: 尼龙 Insulation: Nylon
温度: 105℃ Temperature: 105℃
表面处理: 镀锡 Plating: Tin

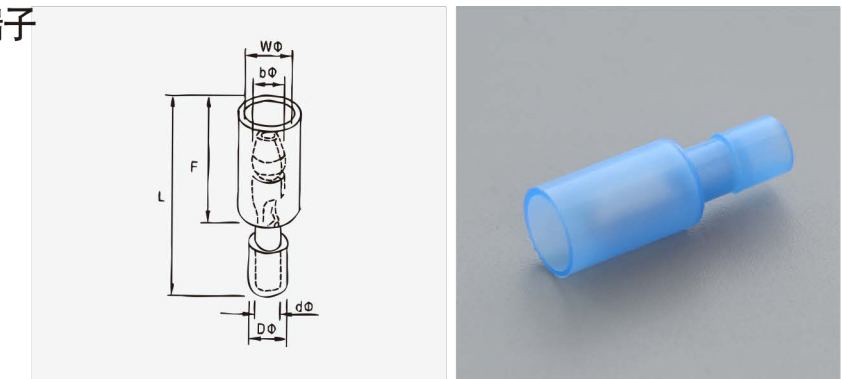

型号 Item NO	导线截面mm ² Cable Size A.W.G	最大电流 Max Current	材料厚度 Thickness (mm)	尺寸 Dimension(mm)						颜色 Color
				W φ	b φ	D φ	d φ	L	F	
MRFNY1.25-156	0.5-1.5 (22-16)	15A	0.4	7.5	4.0	4.3	1.8	25.5	15	红 red
MRFNY2-156	1.5-2.5 (16-14)	24A	0.4	7.5	4.0	4.5	2.4	25.5	15	蓝 blue

无绝缘护套管形端子

(适用于软线)

Non-Insulated Cord End Terminal

(apply In Flexible Wire)

材质: 紫铜 Terminal Body: Copper
表面处理: 镀锡 Plating: Tin

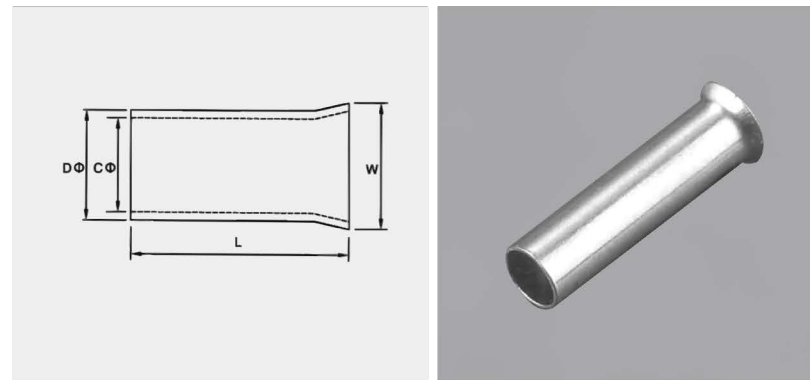

型号 Item NO	尺寸 Dimension(mm)				导线截面mm ² Cable Size	
	L	D φ	C φ	W	A.W.G	mm ²
EN 0306	6.0	1.1	0.9	1.4	#28	0.3
EN 0308	8.0					
EN 0310	10.0					
EN 0506	6.0	1.3	1.0	1.7	#22	0.5
EN 0508	8.0					
EN 0510	10.0					
EN 0512	12.0					
EN 7506	6.0	1.6	1.3	1.9	#20	0.75
EN 7508	8.0					
EN 7510	10.0					
EN 7512	12.0					
EN 1006	6.0	1.8	1.5	2.2	#18	1.0
EN 1008	8.0					
EN 1010	10.0					
EN 1012	12.0					
EN 1507	7.0	2.0	1.7	2.5	#22	0.5
EN 1508	8.0					
EN 1510	10.0					
EN 1512	12.0					
EN 1518	18.0					
EN 2507	7.0	2.6	2.3	3.3	#14	2.5
EN 2508	8.0					
EN 2510	10.0					
EN 2512	12.0					
EN 2518	18.0	3.2	2.8	3.9	#12	4.0
EN 4009	9.0					
EN 4012	12.0					
EN 4018	18.0	3.9	3.5	4.8	#10	6.0
EN 6010	10.0					
EN 6012	12.0					
EN 6015	15.0					
EN6018	18.0					

无绝缘护套管形端子

(适用于软线)

Non-Insulated Cord End Terminal

(apply In Flexible Wire)

材质: 紫铜 Terminal Body: Copper
表面处理: 镀锡 Plating: Tin

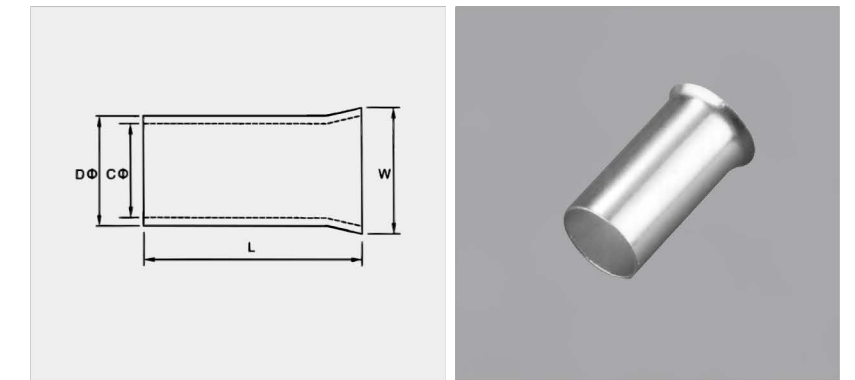

型号 Item NO	尺寸 Dimension(mm)				导线截面mm ² Cable Size	
	L	D φ	C φ	W	A.W.G	mm ²
EN 10-12	12.0	4.9	4.5	5.8	#7	10.0
EN 10-15	15.0					
EN 10-18	18.0					
EN 16-12	12.0	6.2	5.8	7.2	#5	16.0
EN 16-15	15.0					
EN 16-18	18.0					
EN 25-16	16.0	7.9	7.5	9.1	#4	25
EN 25-22	22.0					
EN 35-16	16.0	8.7	8.3	10.2	#2	35.0
EN 35-25	25.0					
EN 50-20	20.0	10.9	10.3	12.4	#11	50.0
EN 50-25	25.0					
EN 70-20	20.0	14.3	13.5	15.3	#2/0	70.0
EN 70-25	25.0					
EN 95-25	25.0	15.5	14.7	16.6	#3/0	95.0
EN 95-32	32.0					
EN 120-30	30.0	17.6	16.7	18.6	#4/0	120
EN 120-32	32.0					
EN 150-27	27.0	20.5	19.5	21.5	#250/300	150
EN 150-32	32.0					

尼龙绝缘护套管形端子

(适用于软线)

Nylon-Insulated Cord End Terminal
(apply In Flexible Wire)

材质: 紫铜 Terminal Body: Copper
 护套: 尼龙 Insulation: Nylon
 温度: 105℃ Temperature: 105℃
 表面处理: 镀锡 Plating: Tin

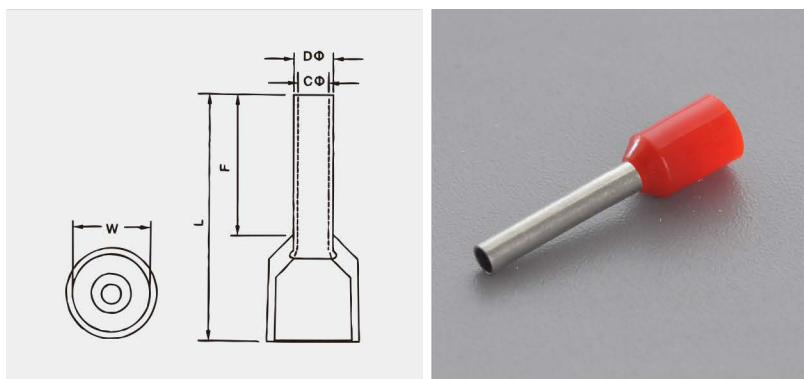

型号 Item NO	尺寸 Dimension(mm)					导线截面mm ² Cable Size		颜色Color	
	F	L	W	Dφ	Cφ	A.W.G	mm ²	德国 Germany	法国用France
EVN0306	6.0	9.8	1.9	1.1	0.8	#24	0.3	浅蓝色 Light blue	粉色 Pink
EVN0308	8.0	11.8							
EVN0310	10.0	13.8							
EVN0506	6.0	12.0	2.6	1.3	1.0	#22	0.5	橙色 Orange	白色 White
EVN0508	8.0	14.0							
EVN0510	10.0	16.0							
EVN0512	12.0	18.0							
EVN7506	6.0	12.4	2.8	1.6	1.3	#20	0.75	白色 White	蓝色 blue
EVN7508	8.0	14.4							
EVN7510	10.0	16.4							
EVN7512	12.0	18.4							
EVN1006	6.0	12.6	3.3	1.8	1.5	#18	1.0	黄色 yellow	红色 Red
EVN1008	8.0	14.6							
EVN1010	10.0	16.6							
EVN1012	12.0	18.6							
EVN1508	8.0	14.8							
EVN1510	10.0	16.8	3.7	2.0	1.7	#16	1.5	红色 Red	黑色 Black
EVN1512	12.0	18.8							
EVN1518	18.0	24.8							
EVN2508	8.0	15.0	4.3	2.6	2.3	#14	2.5	蓝色 blue	灰色 gray
EVN2510	10.0	17.0							
EVN2512	12.0	19.0							
EVN2518	18.0	25.0	4.9	3.2	2.8	#12	4.0	灰色 gray	橙色 Orange
EVN4012	12.0	20.0							
EVN4018	18.0	26.0							
EVN6010	10.0	19.5	6.0	3.9	3.5	#10	6.0	黑色 Black	绿色 Green
EVN6012	12.0	21.5							
EVN6018	18.0	27.5							

尼龙绝缘护套管形端子

(适用于软线)

Nylon-Insulated Cord End Terminal
(apply In Flexible Wire)

材质: 紫铜 Terminal Body: Copper
 护套: 尼龙 Insulation: Nylon
 温度: 105℃ Temperature: 105℃
 表面处理: 镀锡 Plating: Tin

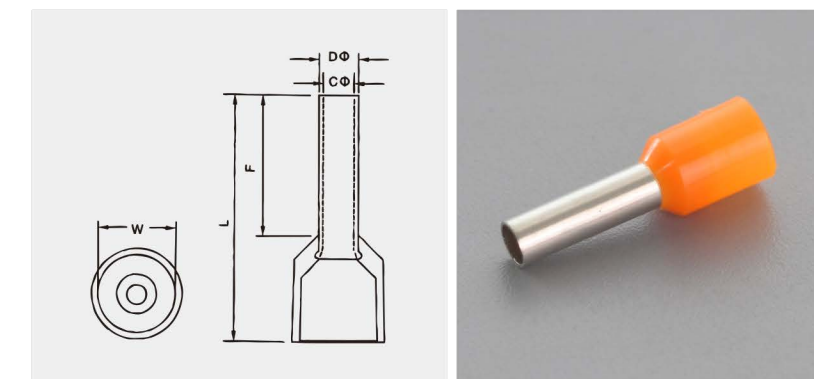

型号 Item NO	尺寸 Dimension(mm)					导线截面mm ² Cable Size		颜色Color	
	F	L	W	Dφ	Cφ	A.W.G	mm ²	德国 Germany	法国用France
EVN10-12	12.0	23.2	7.8	4.9	4.5	#7	10.0	乳白色 milky	褐色 Brown
EVN10-18	18.0	29.2							
EVN16-12	12.0	23.0	9.0	6.2	5.8	#5	16.0	绿色 Green	乳白色 milky
EVN16-18	18.0	29.0							
EVN25-16	16.0	28.0	11.0	7.9	7.5	#4	25.0	褐色 Brown	黑色 Black
EVN25-22	22.0	34.0							
EVN36-16	16.0	30.0	12.6	8.7	8.3	#2	35.0	乳白色 milky	红色 Red
EVN35-22	25.0	39.0							
EVN50-20	20.0	36.0	15.0	10.9	10.3	#1	50.0	橄榄色 olive	蓝色 Blue
EVN50-25	25.0	41.0							
EVN70-20	20.0	36.0	17.2	14.3	13.5	#210	70.0	黄色 yellow	黄色 yellow
EVN70-25	25.0	41.0							
EVN95-25	25.0	44.0	19.2	15.5	14.7	#310	95.0	红色 Red	红色 Red
EVN95-32	32.0	51.0							
EVN120-27	27.0	48.0	21.4	17.6	16.7	#410	120.0	蓝色 Blue	蓝色 Blue
EVN120-32	32.0	53.0							
EVN150-27	27.0	53.0	25.0	20.5	19.5	#250/300 MCB	150.0	黄色 yellow	黄色 yellow
EVN150-32	32.0	58.0							

尼龙绝缘护套双线管形端子

(适用于软线)

Nylon-Insulated Twin Cord End Terminal
(apply In Flexible Wire)

材质: 紫铜 Terminal Body: Copper
 护套: 尼龙 Insulation: Nylon
 温度: 105°C Temperature: 105°C
 表面处理: 镀锡 Plating: Tin

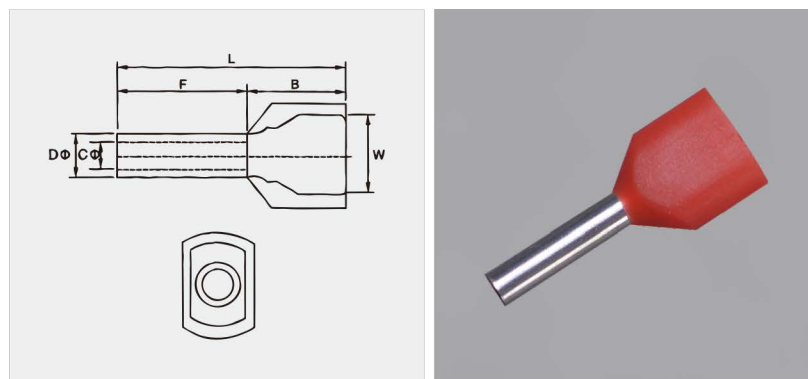

型号 Item NO	导线截面 Conductor mm ²	尺寸 Dimension(mm)						颜色Color	
		F	L	W	B	Dφ	Cφ	德国 Germany	法国用France
TEVN0508	2x0.5	8.0	15	5.0	7.0	1.8	1.5	橙色Orange	白色White
TEVN7508	2x0.75	8.0	15.3	5.5	7.3	2.1	1.8	白色White	蓝色 blue
TEVN7510	2x0.75	10.0	17.3	5.5	7.3	2.1	1.8		
TEVN1008	2x1.0	8.0	15.3	5.5	7.3	2.3	2.0	黄色yellow	红色 Red
TEVN1010	2x1.0	10.0	17.3	5.5	7.3	2.3	2.0		
TEVN1508	2x1.5	8.0	16	6.4	8.0	2.6	2.3	红色 Red	黑色 Black
TEVN1512	2x1.5	12.0	20	6.4	8.0	2.6	2.3		
TEVN2508	2x2.5	8.0	17.3	8.0	9.3	3.3	2.9	蓝色 blue	灰色 gray
TEVN2510	2x2.5	8.0	19.3	8.0	9.3	3.3	2.9		
TEVN2512	2x2.5	12.0	22.3	8.0	9.3	3.3	2.9		

尼龙绝缘护套双线管形端子

(适用于软线)

Nylon-Insulated Twin Cord Endterminal
(apply In Flexible Wire)

材质: 紫铜 Terminal Body: Copper
 护套: 尼龙 Insulation: Nylon
 温度: 105°C Temperature: 105°C
 表面处理: 镀锡 Plating: Tin

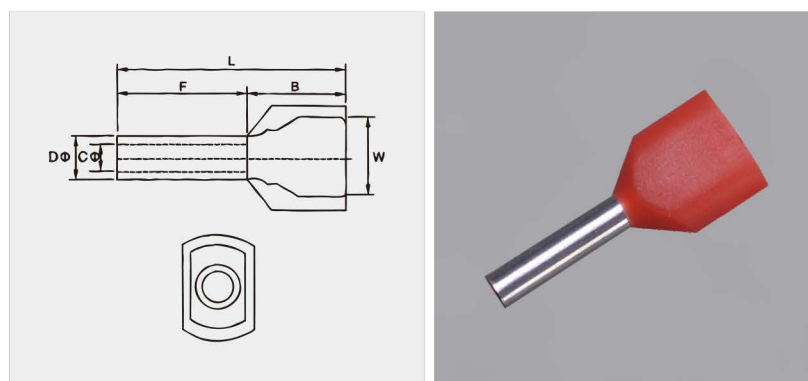

型号 Item NO	导线截面 Conductor mm ²	尺寸 Dimension(mm)						颜色Color	
		F	L	W	B	Dφ	Cφ	德国 Germany	法国用France
TEVN4012	2x4.0	12.0	22.5	8.8	10.5	4.2	3.8	灰色 gray	橙色Orange
TEVN6014	2x6.0	14.0	24.5	9.5	10.5	5.3	4.9	黑色 Black	绿色Green
TEVN10-14	2x10.0	14.0	26.3	12.6	12.3	6.9	6.5	乳白色 milky	褐色Brown
TEVN16-14	2x16.0	14.0	31.5	19.0	17.5	8.7	8.3	绿色Green	乳白色 milky

SC开口端子

SC copper tube terminals

T2紫铜管

T2 purple copper

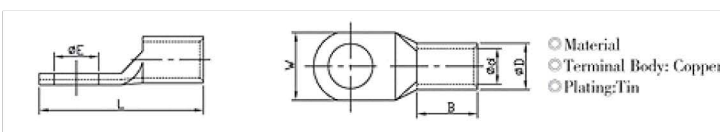

PartNo.型号	Dimension尺寸(mm)					
	ΦE	ΦD	Φd	W	B	L
SC1.5-4	4.2	3.6	1.8	8	5	16
SC1.5-5	5.2	3.6	1.8	10	5	17
SC1.5-6	6.5	3.6	1.8	10	5	18
SC2.5-4	4.2	3.9	2.4	8	7	18
SC2.5-5	5.2	3.9	2.4	10	7	20
SC2.5-6	6.5	3.9	2.4	10	7	20
SC2.5-8	8.4	3.9	2.4	12.5	7	23
SC4-4	4.2	4.7	3.1	10	7	20
SC4-5	5.2	4.7	3.1	10	7	20
SC4-6	6.5	4.7	3.1	10	7	20
SC4-8	8.4	4.7	3.1	12.5	7	23
SC6-4	4.2	5.4	3.8	10	9	24
SC6-5	5.2	5.4	3.8	10	9	24
SC6-6	6.5	5.4	3.8	12	9	24
SC6-8	8.4	5.4	3.8	12.5	9	26
SC6-10	10.5	6	4	15	9	28
SC10-5	5.2	6.1	4.5	12	9	25
SC10-6	6.5	6.1	4.5	12	9	25
SC10-8	8.4	6.1	4.5	12.5	9	27
SC10-10	10.5	6.1	4.5	15	9	29
SC10-12	13	6.1	4.5	17	9	31
SC16-5	5.2	7	5.4	12	12	30
SC16-6	6.5	7	5.4	12	12	30
SC16-8	8.4	7	5.4	12.5	12	30
SC16-10	10.5	7	5.4	16	12	33
SC16-12	13	7	5.4	17	12	35
SC25-5	5.2	8.6	6.8	13	12	33
SC25-6	6.5	8.6	6.8	13	12	33
SC25-8	8.4	8.6	6.8	15	12	33
SC25-10	10.5	8.6	6.8	18	12	34
SC25-12	13	8.6	6.8	18	12	35
SC25-14	15	8.6	6.8	20	12	38
SC35-5	5.2	10.4	8.2	16	14	38
SC35-6	6.5	10.4	8.2	16	14	38
SC35-8	8.4	10.4	8.2	16	14	38
SC35-10	10.5	10.4	8.2	18	14	39
SC35-12	13	10.4	8.2	19	14	40.5
SC35-14	15	10.4	8.2	20	14	42
SC50-6	6.5	12.2	9.5	17.8	16	45
SC50-8	8.4	12.2	9.5	17.8	16	45
SC50-10	10.5	12.2	9.5	17.8	16	45
SC50-12	13	12.2	9.5	20	16	45
SC50-14	15	12.2	9.5	22	16	46
SC50-16	17	12.2	9.5	24	16	47
SC70-8	8.4	14.4	11.2	21	20	52
SC70-10	10.5	14.4	11.2	21	20	52
SC70-12	13	14.4	11.2	21	20	52
SC70-14	15	14.4	11.2	21	20	52

SC开口端子
SC copper tube terminals

T2紫铜管
T2 purple copper

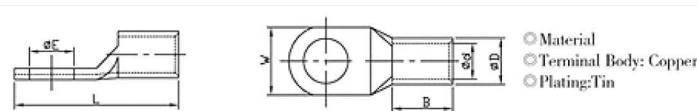

PartNo.型号	Dimension尺寸(mm)					
	ΦE	ΦD	Φd	W	B	L
SC70-16	17	14.4	11.2	25	20	53
SC95-8	8.4	17.1	13.5	25	23	58
SC95-10	10.5	17.1	13.5	25	23	58
SC95-12	13	17.1	13.5	25	23	58
SC95-14	15	17.1	13.5	25	23	58
SC95-16	17	17.1	13.5	25	23	58
SC120-8	8.4	19	15	27.5	22	63
SC120-10	10.5	19	15	27.5	22	63
SC120-12	13	19	15	27.5	22	63
SC120-14	15	19	15	27.5	22	63
SC120-16	17	19	15	27.5	22	63
SC120-20	21	19	15	27.5	22	63
SC150-8	8.4	20.8	16.5	30	26	70
SC150-10	10.5	20.8	16.5	30	26	70
SC150-12	13	20.8	16.5	30	26	70
SC150-14	15	20.8	16.5	30	26	70
SC150-16	17	20.8	16.5	30	26	70
SC150-20	21	20.8	16.5	30	26	70
SC185-10	10.5	23.1	18.5	33.5	32	75
SC185-12	13	23.1	18.5	33.5	32	75
SC185-14	15	23.1	18.5	33.5	32	75
SC185-16	17	23.1	18.5	33.5	32	75
SC185-20	21	23.1	18.5	33.5	32	75
SC240-10	10.5	26	21	38	38	90
SC240-12	13	26	21	38	38	90
SC240-14	15	26	21	38	38	90
SC240-16	17	26	21	38	38	90
SC240-18	19	26	21	38	38	90
SC240-20	21	26	21	38	38	90
SC300-10	10.5	29.4	23.5	43	42	98
SC300-12	13	29.4	23.5	43	42	98
SC300-14	15	29.4	23.5	43	42	98
SC300-16	17	29.4	23.5	43	42	98
SC300-20	21	29.4	23.5	43	42	98
SC400-10	10.5	35.8	28.5	52	44	110
SC400-12	13	35.8	28.5	52	44	110
SC400-14	15	35.8	28.5	52	44	110
SC400-16	17	35.8	28.5	52	44	110
SC400-20	21	35.8	28.5	52	44	110
SC500-10	10.5	38.2	30	55	48	120
SC500-12	13	38.2	30	55	48	120
SC500-14	15	38.2	30	55	48	120
SC500-16	17	38.2	30	55	48	120
SC500-20	21	38.2	30	55	48	120
SC630-10	10.5	44.1	35	63.5	56	140
SC630-12	13	44.1	35	63.5	56	140
SC630-14	15	44.1	35	63.5	56	140
SC630-16	17	44.1	35	63.5	56	140
SC630-20	21	44.1	35	63.5	56	140

HUP闭口端子
HUP copper tube terminals

T2紫铜管
T2 purple copper

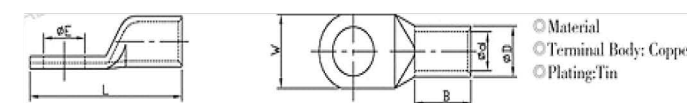

PartNo.型号	Dimension尺寸(mm)					
	ΦE	ΦD	Φd	W	B	L
HUP1.5-3	3.2	3.3	1.8	6.5	6	15.3
HUP1.5-4	4.3	3.3	1.8	6.5	6	17
HUP1.5-6	6.5	3.3	1.8	9	6	22.5
HUP2.5-3	3.2	4.2	2.3	7.5	6	15.3
HUP2.5-4	4.3	4.2	2.3	7.5	6	17
HUP2.5-5	5.3	4.2	2.3	8.5	6	18.8
HUP2.5-6	6.5	4.2	2.3	9.5	6	22.5
HUP2.5-8	8.5	4.2	2.3	13	6	27.8
HUP4-5	5.3	5	3	9	8	21.8
HUP4-6	6.5	5	3	10	8	25.5
HUP4-8	8.5	5	3	13	8	30.5
HUP6-5	5.3	6.5	3.5	10	9	27.5
HUP6-6	6.5	6.5	3.5	12	9	27.5
HUP6-8	8.5	6.5	3.5	15	9	33
HUP6-10	10.5	6.5	3.5	17	9	37
HUP6-12	13	6.5	3.5	19	9	41
HUP10-5	5.3	7	4.5	12	10	28.5
HUP10-6	6.5	7	4.5	12	10	28.5
HUP10-8	8.5	7	4.5	15	10	35
HUP10-10	10.5	7	4.5	17	10	39
HUP10-12	13	7	4.5	19	10	42
HUP16-5	5.3	8.5	5.5	12	13	32.5
HUP16-6	6.5	8.5	5.5	12	13	33.3
HUP16-8	8.5	8.5	5.5	15	13	37.5
HUP16-10	10.5	8.5	5.5	17	13	41.5
HUP16-12	13	8.5	5.5	19	13	45
HUP16-14	15	8.5	5.5	21	13	45
HUP25-5	5.3	10	7	14	15	37.5
HUP25-6	6.5	10	7	14	15	37.5
HUP25-8	8.5	10	7	16	15	42
HUP25-10	10.5	10	7	18	15	46
HUP25-12	13	10	7	19	15	48
HUP25-14	15	10	7	21	15	52.5
HUP35-6	6.5	12	8.5	17	17	39.5
HUP35-8	8.5	12	8.5	17	17	44
HUP35-10	10.5	12	8.5	19	17	49
HUP35-12	13	12	8.5	21	17	51
HUP35-14	15	12	8.5	21	17	54.5
HUP35-16	17	12	8.5	26	17	58
HUP50-6	6.5	14	10	20	19	47
HUP50-8	8.5	14	10	20	19	47
HUP50-10	10.5	14	10	20	19	51
HUP50-12	13	14	10	23	19	56
HUP50-14	15	14	10	23	19	59.5
HUP50-16	17	14	10	28	19	62
HUP50-20	21	14	10	30	19	67
HUP70-6	6.5	16.5	12	23.5	21	53
HUP70-8	8.5	16.5	12	23.5	21	53

HUP闭口端子
HUP copper tube terminals

T2紫铜管
T2 purple copper

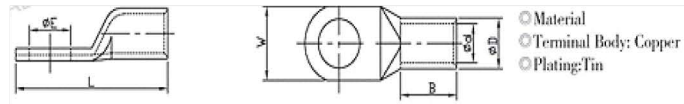

PartNo.型号	Dimension尺寸(mm)					
	ΦE	ΦD	Φd	W	B	L
HUP70-10	10.5	16.5	12	23.5	21	56
HUP70-12	13	16.5	12	23.5	21	59
HUP70-14	15	16.5	12	23.5	21	62.5
HUP70-16	17	16.5	12	28	21	66
HUP70-20	21	16.5	12	30	21	72
HUP95-8	8.5	18	13.5	26	25	60
HUP95-10	10.5	18	13.5	26	25	60
HUP95-12	13	18	13.5	26	25	62
HUP95-14	15	18	13.5	26	25	65.5
HUP95-16	17	18	13.5	28	25	70
HUP95-20	21	18	13.5	36	26	82
HUP120-8	8.5	19.5	15	28	26	65
HUP120-10	10.5	19.5	15	28	26	65
HUP120-12	13	19.5	15	28	26	65
HUP120-14	15	19.5	15	28	26	67
HUP120-16	17	19.5	15	30	26	70
HUP120-20	21	19.5	15	36	28	85
HUP150-8	8.5	21	16.5	30.5	30	70
HUP150-10	10.5	21	16.5	30.5	30	72
HUP150-12	13	21	16.5	30.5	30	72
HUP150-14	15	21	16.5	30.5	30	72
HUP150-16	17	21	16.5	30.5	30	74
HUP150-20	21	21	16.5	36	30	88

GC喇叭口端子
Gccopper tube terminals

T2紫铜管
T2 purple copper

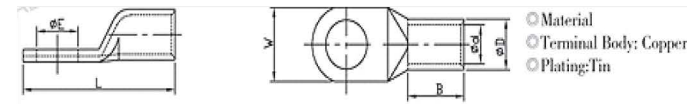

PartNo.型号	Dimension尺寸(mm)					
	ΦE	ΦD	Φd	W	B	L
GC1.5-3	3.2	3.7	1.8	8	6	16
GC1.5-4	4.3	3.7	1.8	8	6	17
GC1.5-5	5.3	3.7	1.8	10	7	19
GC1.5-6	6.5	3.7	1.8	10	7	20
GC2.5-3	3.2	3.9	2.3	8	7	17
GC2.5-4	4.3	3.9	2.3	8	7	18
GC2.5-5	5.3	3.9	2.3	10	7	20
GC2.5-6	6.5	3.9	2.3	10	7	20
GC2.5-8	8.3	4.3	2.3	12.5	7	22.5
GC4-4	4.3	4.7	3	10	8	21
GC4-5	5.3	4.7	3	10	8	22
GC4-6	6.5	4.7	3	10	8	23
GC4-8	8.3	4.7	3	12.5	8	24
GC6-4	4.3	5.9	4	10	9.5	24.6
GC6-5	5.3	5.9	4	10	9.5	24.6
GC6-6	6.5	5.9	4	11	9.5	24.6
GC6-8	8.3	5.9	4	12.5	9.5	27.3
GC6-10	10.3	6.2	4	15	9.5	28.3
GC10-4	4.3	6.6	4.5	11	13	30
GC10-5	5.3	6.6	4.5	11	13	30
GC10-6	6.5	6.6	4.5	11	13	30
GC10-8	8.3	6.6	4.5	12.5	13	30
GC10-10	10.3	6.9	4.5	16	13	34.1
GC10-12	12.7	6.9	4.5	18	12	34.1
GC16-5	5.3	7.5	5.5	11	14	30.7
GC16-6	6.5	7.5	5.5	11	14	30.7
GC16-8	8.3	7.5	5.5	12.5	13	30.7
GC16-10	10.3	7.5	5.5	16	14	35.9
GC16-12	12.7	8.1	5.5	18	13	35.9
GC25-5	5.3	9.1	6.7	13	13	32.2
GC25-6	6.5	9.1	6.7	13	13	32.2
GC25-8	8.3	9.1	6.7	13	13	32.2
GC25-10	10.3	9.1	6.7	16	14	36.9
GC25-12	12.7	9.1	6.7	18	13	36.9
GC25-14	14.8	9.1	6.7	20	13	38.9
GC35-5	5.3	11	8.6	16	16	37.6
GC35-6	6.5	11	8.6	16	16	37.6
GC35-8	8.3	11	8.6	16	16	37.6
GC35-10	10.3	11	8.6	16.7	16	41.5
GC35-12	12.7	11	8.6	18	16	41.5
GC35-14	14.8	11	8.6	20	16	43.5
GC35-16	16.5	11	8.6	23	16	45.5
GC50-5	5.3	12.4	9.5	18	17	41
GC50-6	6.5	12.4	9.5	18	17	41
GC50-8	8.3	12.4	9.5	18	17	41
GC50-10	10.3	12.4	9.5	18	17	44
GC50-12	12.7	12.4	9.5	19	17	44
GC50-14	14.8	12.4	9.5	21	19	52.8

GC喇叭口端子 Gccopper tube terminals

T2紫铜管
T2 purple copper

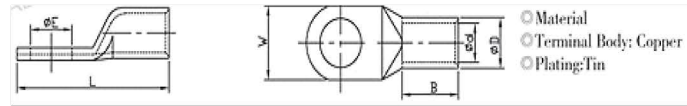

PartNo.型号	Dimension尺寸(mm)					
	ΦE	ΦD	Φd	W	B	L
GC50-16	16.5	12.4	9.5	23	19	52.8
GC70-5	5.3	15	12	22	21.5	52.4
GC70-6	6.3	15	12	22	21.5	52.4
GC70-8	8.3	15	12	22	21.5	52.4
GC70-10	10.3	15	12	22	21.5	52.4
GC70-12	12.7	15	12	22	21.5	52.4
GC70-14	14.8	15	12	22	21.5	55
GC70-16	16.5	15	12	24	20	55
GC95-8	8.3	17	13.4	25	22.5	54.7
GC95-10	10.3	17	13.4	25	22.5	54.7
GC95-12	12.7	17	13.4	25	22.5	54.7
GC95-14	14.8	17	13.4	25	22.5	58.3
GC95-16	16.8	17	13.4	25	22.5	58.3
GC120-8	8.3	19	15	27	23	60
GC120-10	10.3	19	15	27	23	60
GC120-12	12.7	19	15	27	23	60
GC120-14	14.8	19	15	27	23	64
GC120-16	16.5	19	15	27	23	64
GC150-10	10.3	21.2	16.5	30	27	67
GC150-12	12.7	21.2	16.5	30	27	67
GC150-14	14.8	21.2	16.5	30	27	67
GC150-16	16.5	21.2	16.5	30	27	71.4
GC150-20	20.9	21.2	16.5	30	27	71.4

GPH90度端子 GPH90 copper tube terminals

T2紫铜管
T2 purple copper

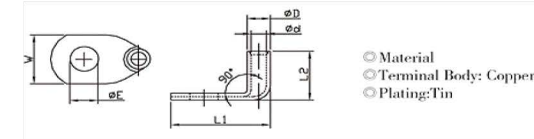

PartNo.型号	Dimension尺寸(mm)					
	ΦE	ΦD	Φd	W	B	L
GPH90-6/5	5.3	6.5	3.5	10	14	22.5
GPH90-6/6	6.4	6.5	3.5	12	14	24
GPH90-6/8	8.5	6.5	3.5	15	14	27.5
GPH90-6/10	10.5	6.5	3.5	16	14	29.5
GPH90-10/5	5.3	7	4.5	12	16	23
GPH90-10/6	6.4	7	4.5	12	16	24
GPH90-10/8	8.5	7	4.5	15	16	28
GPH90-10/10	10.5	7	4.5	18	16	29.5
GPH90-16/5	5.3	8.5	5.5	12	20	22.5
GPH90-16/6	6.4	8.5	5.5	14	20	24
GPH90-16/8	8.5	8.5	5.5	15	20	28
GPH90-16/10	10.5	8.5	5.5	18	20	31
GPH90-16/12	13	8.5	5.5	19	20	32
GPH90-25/6	6.4	10	6.9	15	21	27.5
GPH90-25/8	8.4	10	6.9	16	21	32.5
GPH90-25/10	10.5	10	6.9	18	21	32.5
GPH90-25/12	13	10	6.9	19	21	34
GPH90-35/6	6.4	12	8.5	17	24	28.5
GPH90-35/8	8.5	12	8.5	17	24	34
GPH90-35/10	10.5	12	8.5	20	24	34
GPH90-35/12	13	12	8.5	22	24	40.5
GPH90-50/6	6.4	14	10	20	28.5	37
GPH90-50/8	8.4	14	10	20	28.5	40.5
GPH90-50/10	10.5	14	10	20	28.5	40.5
GPH90-50/12	13	14	10	23	28.5	42.5
GPH90-50/16	17	14	10.0	28	28.5	50.5
GPH90-70/8	8.5	16.5	12	24	31	43
GPH90-70/10	10.5	16.5	12	24	31	43
GPH90-70/12	13	16.5	12	24	31	44.5
GPH90-70/16	17	16.5	12	28	31	53
GPH90-70/20	21	16.5	12	30	31	59
GPH90-95/8	8.5	18	13.5	26	35	44.5
GPH90-95/10	10.5	18	13.5	26	35	44.5
GPH90-95/12	13	18	13.5	26	35	46.5
GPH90-95/16	17	18	13.5	28	35	52
GPH90-95/20	21	18	13.5	30.5	35	59
GPH90-120/10	10.5	19.5	15	29	35.5	49
GPH90-120/12	13	19.5	15	29	35.5	49
GPH90-120/16	17	19.5	15	29	35.5	55
GPH90-120/20	21	19.5	15	30.5	35.5	61
GPH90-150/10	10.5	21	16.5	31	40	48
GPH90-150/12	13	21	16.5	31	40	51
GPH90-150/16	17	21	16.5	31	40	56
GPH90-150/20	21	21	16.5	34	40	61.5